

driven by perfection

walter
PRÄZISION



TANi
evolution
H2S & H2S-XS

2 axes for us are 5 faces for you!

Perfect for 5-face machining TANIH2S-Evolution and TANIH2S-Evolution XS

TANi evolution H2S & H2S-XS

“Evolution” is improvement by development

The tiltable dividing-head TANIH-2S Evolution and TANIH2S-Evolution XS combine the traditional values of perfection and premium class with the most innovative developments – also in the 5-axes range. The series is based on the TANIH-Evolution range.

The 2-axes NC-dividing head TANIH2S-Evolution, with its 2 full CNC axes, is characterised by the highest efficiency with a very compact design. The WALTER TRIPLEX clamping system gives you highest possible holding torques for heavy-duty machining.

The 2-axes NC-dividing head TANIH2S-Evolution XS, with its 2 full CNC axes, is characterised by the highest efficiency with a very compact design. The rotation axis without a counter bearing is suitable for moderate machining forces. The option of direct measuring systems in both axes to achieve highest accuracies, as well as the possibility to adapt full- or semi-automatic workholding devices gives you the highest precision and effectivity in

your production of parts and sub-assemblies.

Together with the 3 axes of the machine or machining centre, a full 5-axes machining can be realised. The adjustable wormdrive consisting of a case-hardened wormshaft and a bronze-alloy wormwheel, together with various motor-mounting possibilities, gives your production the best possible “drive”.

In evolution, flexibility decides about success!

Premium class, more precise, higher in performance and tiltable.

TANIH2S-Evolution with WALTER-**TRIPLEX*** clamping system
3+2 axes exceed than 5 axes



also available with drive axis mounted in inverse position

TANIH2S-Evolution

The compact and modular system allows the combination of multiple spindles and axes. This combination makes the TANIH2S-Evolution the most comprehensive solution for your manufacturing tasks on complex workpieces. Due to the unique and stunning WALTER TRIPLEX clamping system with 3 clamping-points and a rigid and stable counterbearing, highest holding torques are guaranteed!



TANIH2S-Evolution XS

5-face machining with unrestricted access. Perfect conditions for most production processes in which moderate machining forces occur. This makes the TANIH2S-Evolution XS to a cost-efficient solution for your production.



The advantages in brief

- + NC controlled tilting range from -5° - +95°
- + high precision drive technology and stability
- + WALTER-**TRIPLEX** clamping system for highest holding torques
- + aesthetical stainless steel optics
- + highest precision in mm-range
- + gives your machine the flexibility of 3 or 5 axes

**Highest holding
torques due to the
WALTER-**TRIPLEX***
clamping system**

*The Walter **TRIPLEX** clamping system is the addition of 2 clamping systems in the tilting axis and the clamping system of the rotating axis

Technical data

TANiH2S
evolution

TANiH2S
evolution



also available with drive axis mounted in inverse position



Sizes

The 8 different sizes available cover a large range of machining possibilities and applications.

also available with drive axis mounted in inverse position

Loads

Size mm	max. load (centrally)			total axial force		tilting moment		holding torque hydraulic at 100 bar	
	vertical spindle kg (max.)	tilting movement kg (max.) Nm (dynamic)	horizontal spindle kg (max.) Nm (static)	rotating axis N (max.)	rotating axis Nm	rotating axis Nm	tilting axis Nm	rotating axis Nm	tilting axis Nm
125/125	280	60 kg/110Nm	100 kg/1.200Nm	25.000	1.200	800	1.600		
125/160	280	100 kg/250 Nm	100 kg/1.200Nm	25.000	1.200	800	2.400		
160/160	700	100 kg/250 Nm	180 kg/2.400Nm	40.000	3.300	1.600	2.400		
160/200	700	180 kg/450 Nm	180 kg/3.300Nm	40.000	3.300	1.600	5.600		
200/200	1.000	180 kg/450 Nm	300 kg/5.600Nm	55.000	6.400	4.000	5.600		
200/250	1.000	250 kg/900 Nm	300 kg/6.400Nm	55.000	6.400	4.000	9.000		
250/250	1.400	250 kg/900 Nm	360 kg/9.000Nm	60.000	10.400	5.000	9.000		
250/320	1.400	400 kg/1.800 Nm	360 kg/10.400Nm	60.000	10.400	5.000	14.000		

* values may vary due to customer specific variations

Loads

Size mm	drive torque	reduction ratio worm drive		speed short term speed for positioning		weight	spindle bore rotating axis
	on spindle rotating axis Nm (max.)	rotating axis i=	tilting axis i=	rotating axis min ⁻¹ (max.)	tilting axis min ⁻¹ (max.)	without motor without baseplate kg (appr.)	mm ^Ø
125/125	110	72:1	72:1	42	42	145	50
125/160	110	72:1	72:1	42	42	170	50
160/160	250	72:1	72:1	42	42	200	65
160/200	250	72:1	90:1	42	33	upon request*	65
200/200	450	90:1	90:1	33	33	upon request*	105
200/250	450	90:1	90:1	33	33	upon request*	105
250/250	900	90:1	90:1	33	33	upon request*	150
250/320	900	90:1	90:1	33	33	upon request*	150

* values may vary due to customer specific variations

Technical data

TANiH2S
evolution

Dimensions

TANiH2S
evolution

Accuracies

Size	indexing accuracy (\pm in arc seconds)				
	with indirect measuring system		with direct measuring system (system accuracy)		
	rotating axis	tilting axis	rotating axis / tilting axis		
mm	NEG	NEG	d-A	d-AA	d-AAA
125/125	$\pm 15''$	$\pm 15''$	$\pm 5''$	$\pm 2,5''$	-
125/160	$\pm 15''$	$\pm 15''$	$\pm 5''$	$\pm 2,5''$	$\pm 1,5''$ only tilting axis
160/160	$\pm 15''$	$\pm 15''$	$\pm 5''$	$\pm 2,5''$	$\pm 1,5''$
160/200	$\pm 15''$	$\pm 10''$	$\pm 5''$	$\pm 2,5''$	$\pm 1,5''$
200/200	$\pm 10''$	$\pm 10''$	$\pm 5''$	$\pm 2,5''$	$\pm 1,5''$
200/250	$\pm 10''$	$\pm 10''$	$\pm 5''$	$\pm 2,5''$	$\pm 1,5''$
250/250	$\pm 10''$	$\pm 10''$	$\pm 5''$	$\pm 2,5''$	$\pm 1,5''$
250/320	$\pm 10''$	$\pm 10''$	$\pm 5''$	$\pm 2,5''$	$\pm 1,5''$

Please note: All values given here are approximate values. We keep the right to technical changes due to technical progress without any further notice. Maximum loads depend very much on the geometry of the work-piece. In case of doubt, please contact our technical department for further information.

For binding dimensions, please request an individual dimensional layout. Incremental or absolute encoders can be used as measuring systems. Special concentricity or axial run-out of the spindle is available. Special centre heights and specific base plates are available as option, upon request. Please also see the section "additional equipment".

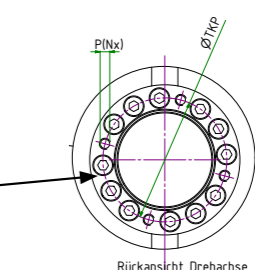
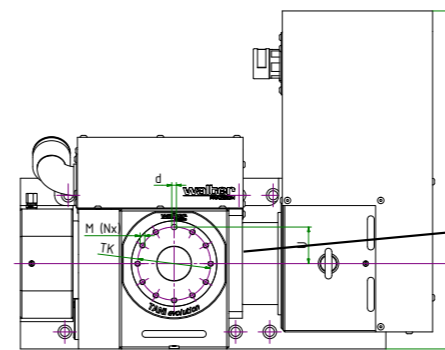
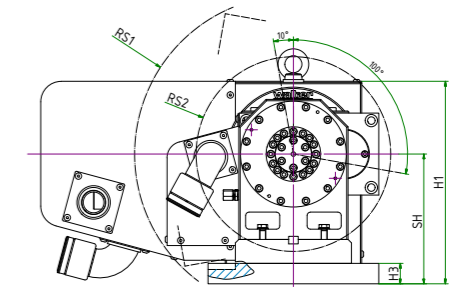
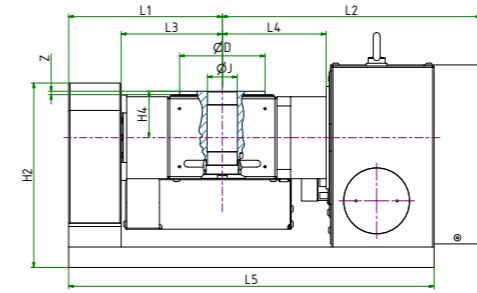

also available with drive axis mounted in inverse position

Accuracies

Size	repeatability (\pm in arc seconds)					concentricity		axial runout
	with indirect measuring system		with direct measuring system			spindle nose	spindle bore	spindle nose
	rotating axis	tilting axis	rotating axis / tilting axis					
mm	NEG	NEG	d-A	d-AA	d-AAA	mm	mm	mm
125/125	$\pm 3''$	$\pm 3''$	$\pm 1''$	$\pm 1''$	-	$\leq 0,008$	$\leq 0,008$	$\leq 0,008$
125/160	$\pm 3''$	$\pm 3''$	$\pm 1''$	$\pm 1''$	$\pm 1''$	$\leq 0,008$	$\leq 0,008$	$\leq 0,008$
160/160	$\pm 3''$	$\pm 3''$	$\pm 1''$	$\pm 1''$	$\pm 1''$	$\leq 0,008$	$\leq 0,008$	$\leq 0,008$
160/200	$\pm 3''$	$\pm 3''$	$\pm 1''$	$\pm 1''$	$\pm 1''$	$\leq 0,008$	$\leq 0,008$	$\leq 0,008$
200/200	$\pm 3''$	$\pm 3''$	$\pm 1''$	$\pm 1''$	$\pm 1''$	$\leq 0,008$	$\leq 0,008$	$\leq 0,008$
200/250	$\pm 3''$	$\pm 3''$	$\pm 1''$	$\pm 1''$	$\pm 1''$	$\leq 0,008$	$\leq 0,008$	$\leq 0,008$
250/250	$\pm 3''$	$\pm 3''$	$\pm 1''$	$\pm 1''$	$\pm 1''$	$\leq 0,008$	$\leq 0,008$	$\leq 0,008$
250/320	$\pm 3''$	$\pm 3''$	$\pm 1''$	$\pm 1''$	$\pm 1''$	$\leq 0,008$	$\leq 0,008$	$\leq 0,008$

Dimensions

Size	B1	B2*	d ^{H7}	D ^{H6}	H1	H2	H3	H4	J ^{H6}	L1	L2	L3	L4	L5
125/125	125	370	8	125	240	210	30	68	50	225	350	148	156	505
125/160	125	370	8	125	295	270	30	68	50	225	380	148	156	535
160/160	160	335	10	150	295	270	30	68	65	245	400	168	190	575
160/200	160	400	10	150	385	345	40	83	65	276	440	180	190	640
200/200	145	420	12	200	385	345	40	97,5	105	320	485	225	230	725
200/250	200	530	12	200	477	435	50	97,5	105	350	530	225	230	800
250/250	upon request													
250/320	upon request													

mm	M(Nx)	P(Nx)	RS1	RS2	SH ^{+0,025}	TK ^{+0,1}	TKP ^{+0,1}	U ^{+0,02}	Z
125/125	M8 (11x)	M6 (4x)	208	120	155	107	66	53,5	5
125/160	M8 (11x)	M6 (4x)	228	140	190	107	66	53,5	5
160/160	M10 (11x)	sur demande	560	308	190	130	upon request	65	4,5
160/200	M10 (11x)	sur demande	560	308	240	130	upon request	65	4,5
200/200	M12 (11x)	M6 (8x)	780	440	240	176	114	88	6
200/250	M12 (11x)	M6 (8x)	780	440	300	176	114	88	6
250/250	upon request								
250/320	upon request								

*dimension B2=depending on motor – here Siemens 1FK7 series

The 2-axis alternative for medium machining forces

for moderate machining forces TANIH2S Evolution XS

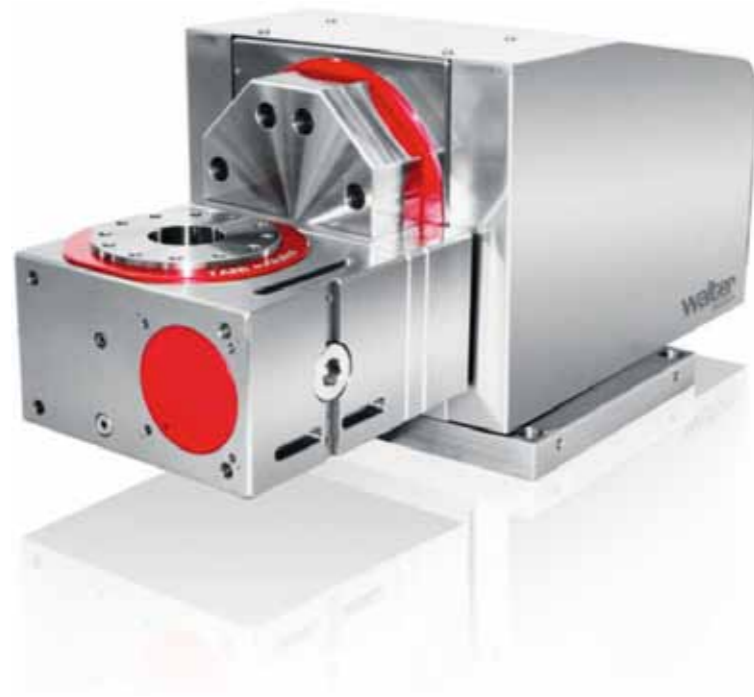

The advantages in brief

- + NC controlled tilting range up to -120° - $+120^\circ$
- + no interfering counter bearing
- + high precision drive technology and stability
- + hydraulic clamping system in both axis
- + aesthetical stainless steel optics
- + highest precision in $m\mu$ -range
- + gives your machine the flexibility of 3 or 5 axes

Technical data

TANIH2S-XS
evolution

Loads

Size	max. load (centrally)			total axial force	tilting moment		holding torque hydraulic at 100 bar	
	vertical spindle	tilting movement	horizontal spindle		rotating axis	rotating axis	tilting axis	rotating axis
mm	kg (max.)	kg (max.) Nm dynamic	kg (max.) Nm static	N (max.)	Nm	Nm	Nm	Nm
80/100	50	30 kg / 45 Nm	25 kg / 250 Nm	3.500	250	900	180	400
100/125	120	45 kg / 110 Nm	80 kg / 350 Nm	18.000	350	1.200	400	800
125/160	280	80 kg / 250 Nm	100 kg / 1.200Nm	25.000	1.200	3.300	800	1.600
160/200	700	120 kg / 450 Nm	180 kg / 3.300Nm	40.000	3.300	6.400	1.600	4.000
200/250	1.000	300 kg / 900 Nm	360 kg / 5.000 Nm	55.000	6.400	10.400	4.000	5.000

Loads

Size	drive torque	reduction ratio		speed		weight	spindle bore
	rotating axis	rotating axis	tilting axis	rotating axis	tilting axis	w/o motor and w/o baseplate	mm ¹⁹ rotating axis
mm	Nm (max.)	i=	i=	min ⁻¹ (max.)	min ⁻¹ (max.)	kg (apr.)	mm
80/100	32	45:1	56:1	133	105	weight varies due to customer specific variations*	32
100/125	45	56:1	72:1	105	42	weight varies due to customer specific variations*	32
125/160	110	72:1	72:1	42	42	weight varies due to customer specific variations*	50
160/200	250	72:1	90:1	42	33	weight varies due to customer specific variations*	65
200/250	450	90:1	90:1	33	33	weight varies due to customer specific variations*	105

* values may vary due to customer specific variations

Technical data

TANiH2S-XS
evolution

Dimensions

TANiH2S-XS
evolution

Accuracies

Size	indexing accuracy				
	with indirect measuring system		with direct measuring system		
	rotating axis	tilting axis	rotating-/tilting axis		
mm	NEG	NEG	d-A	d-AA	d-AAA
80/100	±45°	±30°	±5"	±2,5"	-
100/125	±30°	±15°	±5"	±2,5"	-
125/160	±15°	±15°	±5"	±2,5"	±1,5" only tilting axis
160/200	±15°	±10°	±5"	±2,5"	±1,5"
200/250	±10°	±10°	±5"	±2,5"	±1,5"

Please note: All values given here are approximate values. We keep the right to technical changes due to technical progress without any further notice.

Maximum loads depend very much on the geometry of the work-piece. In case of doubt, please contact our technical department for further information. For binding dimensions, please request an individual dimensional layout.

Incremental or absolute encoders can be used as measuring systems. Special concentricity or axial runout of the spindle is available. Special centre heights and specific base plates are available as option, upon request. Please also see the section "additional equipment".

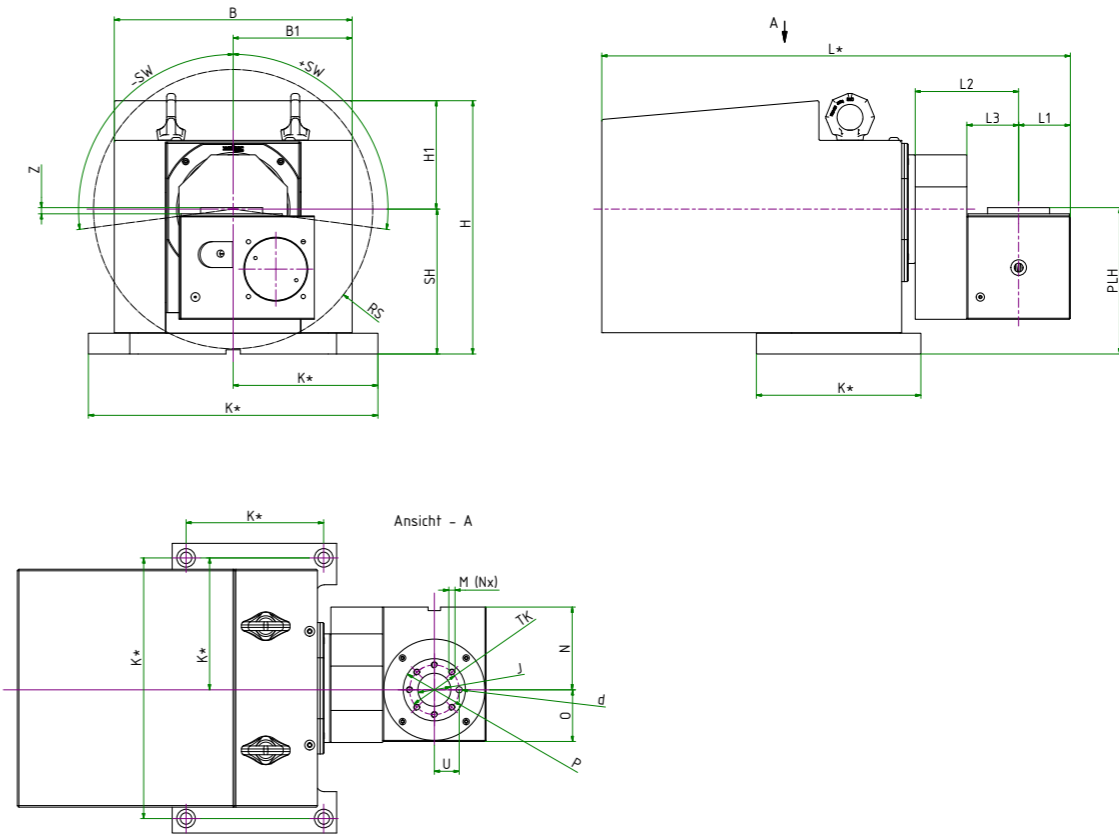

Accuracies

Size	repeatability					concentricity		axial runout
	with indirect measuring system		with direct measuring system			spindle nose	spindle bore	spindle nose
	rotating axis	tilting axis	rotating-/tilting axis					
mm	NEG	NEG	d-A	d-AA	d-AAA	mm	mm	mm
80/100	±3°	±3°	±1"	±1"	±1"	≤0,008	≤0,008	≤0,008
100/125	±3°	±3°	±1"	±1"	±1"	≤0,008	≤0,008	≤0,008
125/160	±3°	±3°	±1"	±1"	±1"	≤0,008	≤0,008	≤0,008
160/200	±3°	±3°	±1"	±1"	±1"	≤0,008	≤0,008	≤0,008
200/250	±3°	±3°	±1"	±1"	±1"	≤0,008	≤0,008	≤0,008

Dimensions

Size	B1	B2	d ^{H7}	D ^{H6}	H1	H2	J ^{H6}	L	L1	L2	L3
80/100	230	115	6	60	255	105	32	*	50	100	50
100/125	270	124	8	105	302	127	32	*	65	140	90
125/160	300	150	8	125	358	168	50	*	80	155	100
160/200	-	-	10	150	-	-	65	*	-	-	-
200/250	-	-	12	200	-	-	105	*	-	-	-

mm	M(Nx)	N	O	PLH	RS	SH ^{+0,025}	+SW	-SW	T ^{+0,05}	TK- $\theta^{0,1}$	U ^{+0,02}
80/100	M6 (7x)	80	50	150	135	150	97,5	97,5	24	48	24
100/125	M8 (7x)	100	65	175	160	175	95	95	43	86	43
125/160	M8 (11x)	125	80	190	180	190	120	120	53,5	107	53,5
160/200	M10 (11x)	160	105	-	-	240	-	-	65,5	176	65
200/250	M12 (11x)	200	145	-	-	290	-	-	65,5	176	88

* dimension L=depending on motor

Additonal Equipment

The additional equipment shown here is only an example of different possibilities. Individual modifications are possible and already available. Many options e.g. zero-point clamping devices, palleting systems, special faceplates, swing-bridges, rotary feed-through, clamping cylinders and many others can be realised.

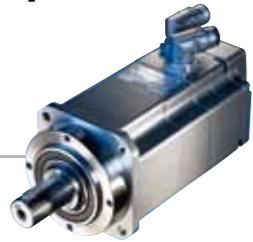

Motors
Alternative motors (e.g. Fanuc, Heidenhain and others) available on request.

Size	80	100	125	160	200	250	320
required torque (min.), at direct connection to the worm shaft	Nm	1,4	1,6	3	7	10	40
SIEMENS 1FK7 series	-	7034	7042	7042	7060	7063	7101*

*using a 2:1 reduction belt drive



Pressure intensifier
air : oil 1:17



CNC Control unit
CNC control with interface for M-functions



Plug- and Play solution
for use as 4th and/or 5th axis for a specific machine type.



Collet chucks
for various types of collets e.g. Schaublin, Hainbuch etc... Power-operated chucks also available. Please ask for details.

Size	80	100	125	160	200	250	320
clamping range	mm	3-22	3-22	3-26	3-42	3-42	*

*on request

Clamping cylinders and rotary distributors
For all clamping solutions. Rotary distributors available in multi core versions for Hydraulic and Pneumatic solutions.



Direct measuring systems – Heidenhain
for highest possible accuracies



Size	80	100	125	160	200	250
accuracy class A**	±5"	*	RCN 226	RCN 226	RCN 226	RCN 226
accuracy class AA**	±2,5"	n.a.	RCN 228	RCN 228	RCN 228	RCN 228
accuracy class AAA**	±1,5"	n.a.	n.a.	RCN 829	RCN 829	RCN 829

* on request **alternative RON/ROD types available



Other workpiece clamping devices.
e.g. zero point clamping systems
EROWA, SYSTEM 3R, UNILOCK, SCHUNK



Faceplates
standard and customer specific solutions available

Size	80	100	125	160	200	250
face plate Ø	mm	100	160	200	250	320
t-slots acc. to DIN 650	mm ^{H8}	8	8	12	12	12
centre bore Ø	mm ^{H7}	22	25	32	32	40
alternative face plate Ø	mm	158	198	248	318	398
t-slots acc. to DIN 650	mm ^{H8}	8	12	12	12	12
centre bore Ø	mm ^{H7}	25	32	32	32	40



spindle insert / customer specific spindle versions
spindle inserts for all typical spindle-cones. Upon request also available as complete spindle unit. Other Special spindles according to customers request and technical producibility.

Size	80	100	125	160	200	250
HSK	25	40	63	80	100	100
HSK (alt. size)	32	50	80	100	-	-
MK	2	3	4/5	5	5/6	6
SK	30	40	40/50	40/50	50	50



3-jaw chucks with mounting flange
These manual chucks offer a safe clamping of your workpieces

Size	80	100	125	160	200	250
chuck Ø	mm	80	100	160	200	250
max. bore Ø	mm	19	20	42	55	76
clamping range	-	2-80	3-100	3-160	4-200	5-250
alternative chuck Ø	mm	100	125	200	250	315
max. bore Ø	mm	20	32	55	76	103
clamping range	-	3-100	3-125	4-200	5-250	6-315

Sketches and notes

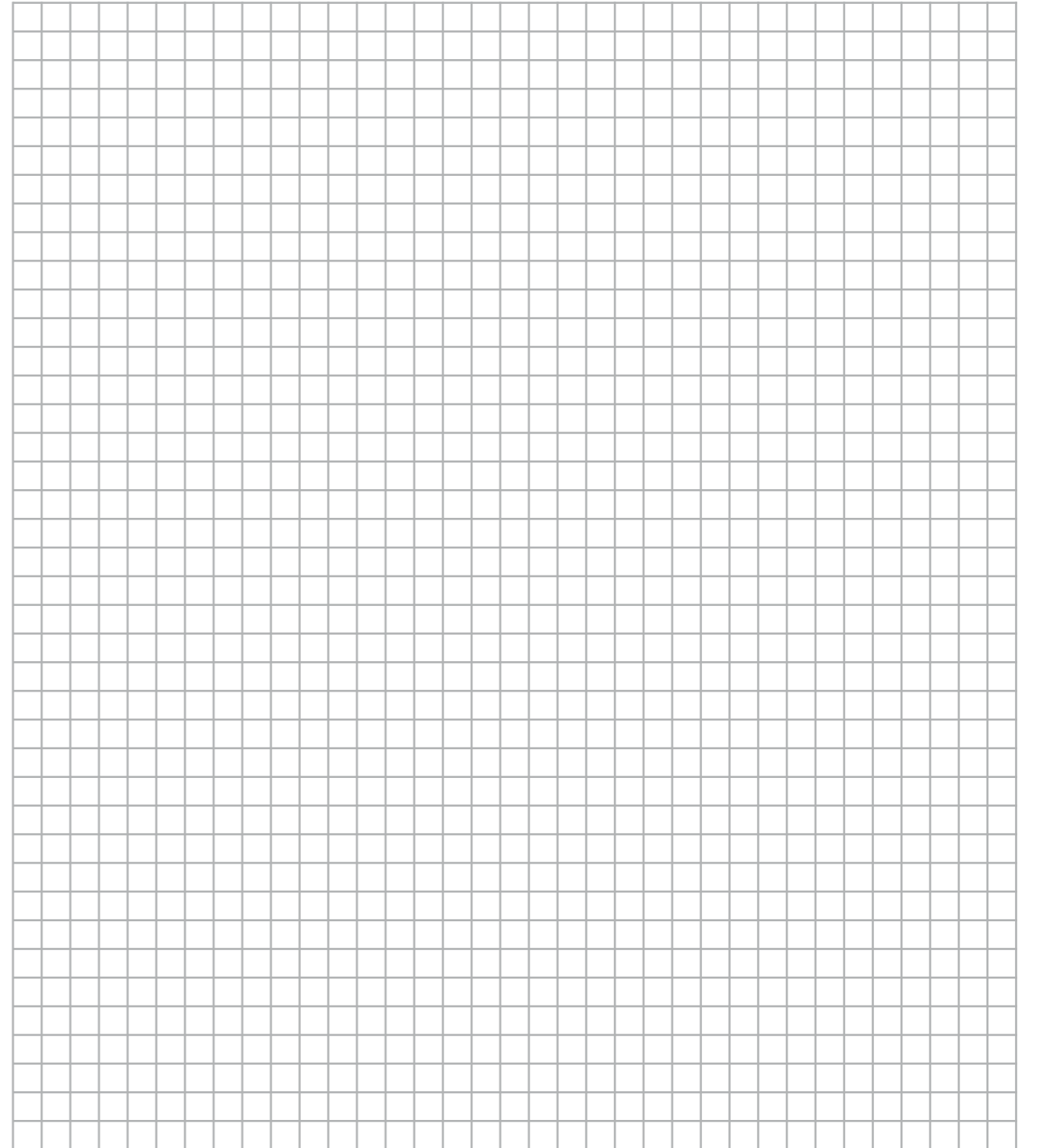
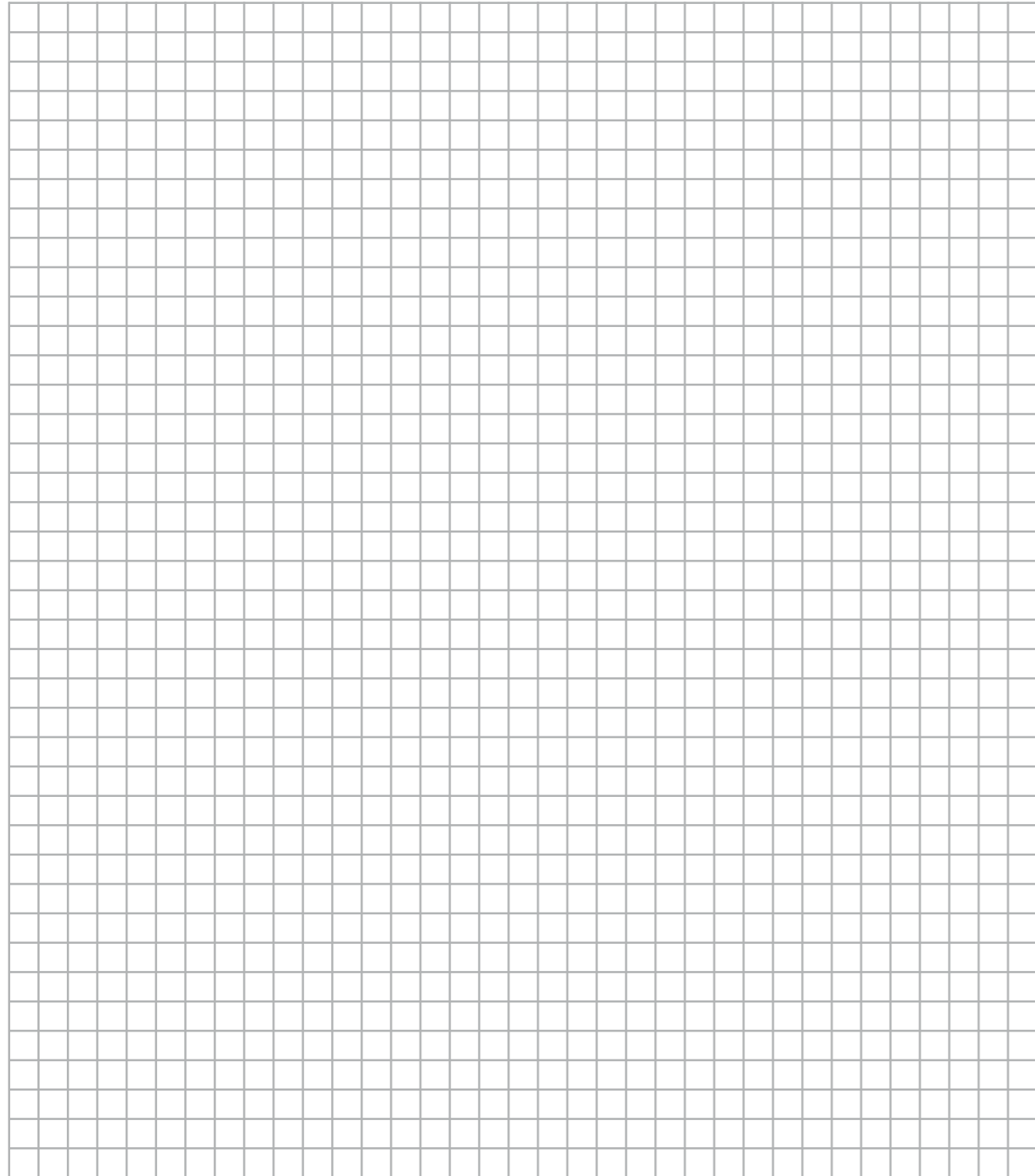

Precise by tradition. Use our experience for your production.



walter
PRÄZISION



Gotthilf Walter GmbH, Spezialfabrik für Teilapparate
Bausteinstraße 15 · 75443 Ötisheim · GERMANY
Postfach 13 53 · 75403 Mühlacker · GERMANY
Phone 07041/800-0 · Fax 07041/800-40
www.walter-praezision.de · info@walter-praezision.de

