

HYDROTECHNIK



MINIMESS®

Sensors

Measuring systems

Service and calibration

2022 Product Catalog

58 YEARS

A System for Measurements

We are an innovative mid-sized company that has firmly established itself as one of the leading providers of industrial measuring equipment for high-pressure system diagnostics and condition monitoring – both nationally and internationally. Moreover, we employ over 140 people worldwide as the Hydrotechnik Group and not only operate locations in Germany, but also sales branches in France, Italy, China, Singapore, Japan, India and

the US.

We provide our customers with unbeatable "Made in Germany" product quality, and our products are manufactured exclusively in Germany. In addition, we are known for cultivating long-term relationships with our customers and offering unrivalled service and solutions for everything having to do with measuring equipment.



MINIMESS®

Sensors

Measuring systems

Service and calibration

Overview – MINIMESS®	Page	8 - 9
Original MINIMESS® test points	Page	10 - 19
Original MINIMESSXtreme® test points	Page	20 - 21
Original MINIMESS® gas charging valves and accessories	Page	22 - 26
Adapters with original MINIMESS® test points	Page	27 - 42
MINIMESS® gauge and sensor adapters, hose lines, and accessories	Page	43 - 57
Expanded MINIMESS® portfolio	Page	58 - 60
Technical notes	Page	61 - 69

Overview – HySense®	Page	72 - 73
Flow meters	Page	74 - 108
Pressure sensors	Page	109 - 137
Temperature sensors	Page	138 - 145
Oil condition sensors	Page	146 - 157
Force sensors	Page	158 - 161
Torque sensors	Page	162 - 163
Speed sensors	Page	164 - 168
Position sensors	Page	169 - 170
Vibration sensors	Page	171 - 172
Signal converter	Page	173

Measuring system overview	Page	178 - 181
2025	Page	182 - 187
3020	Page	188 - 191
4070	Page	192 - 197
5070	Page	198 - 203
8050	Page	204 - 207
SEG 1060	Page	208 - 209
Patrick	Page	210 - 211
Patrick in the box	Page	212 - 213
Software	Page	214 - 217
MultiXtend	Page	218 - 225
Cables	Page	226 - 227
Accessories	Page	229

Range of services	Page	230 - 232
Measured variables at a glance	Page	233 - 235

Trendsetting details and innovations

MINIMESS®

Expertise in everything having to do with hydraulic measuring technology is one of the main constants behind the history of Hydrotechnik. In fact, the **MINIMESS®** plug-in coupling featuring a ball check was first launched on the market in 1964, immediately redefining what was possible in the field of pressure measuring technology for hydraulic systems. And it was no surprise, as the advantages behind the novel development were immediately compelling: Instead of having to open the hydraulic circuit and install a pressure gauge for diagnostic or maintenance activities, the innovation had suddenly made it possible to quickly and safely connect pressure sensors and gauges without any downtime.

The name Hydrotechnik has long been considered a standard-bearer in the area of hydraulic measuring equipment, and that is even before the introduction of its new leak-proof test point with a soft seal in 1982.

Previous developments such as the **MINIMESS®** p/T test point, which can be used to measure pressure and temperature at a single measuring point directly in a fluid, and the **MINIMESS®** gas charging valve, with its excellent gas tightness, had already made it clear that Hydrotechnik GmbH was a force of innovation to be reckoned with.

From small-scale handmade batches to series production









From the very moment Hydrotechnik GmbH was

founded, every single product has been made at the company's headquarters in Limburg an der Lahn. A high level of vertical integration and lean processes enable us to quickly respond to our customers' needs – from handmade small-scale production for the most demanding measuring tasks to mass production. Hydrotechnik GmbH always uses the best approach to provide users with safe, high-quality products that are specifically fine-tuned to match their requirements.

The future looks bright

By continuously enhancing and developing its products for applications in an extremely wide variety of industries and combining that with decades of experience, Hydrotechnik GmbH has remained an unrivaled partner for products and services that go far beyond the classic test point.

From the project phase, through prototypes, to the finished product, we actively support our customers worldwide with the implementation of their projects. In fact, we are known for implementing the most extraordinary applications without ever losing focus on the big picture or on detail and utmost meticulousness. An international presence and unrivaled experience with the **MINIMESS®** make us the ideal partner for your needs – today and well into the future.

<p>ORIGINAL MINIMESS® TEST POINTS The go-to system access solution for fluid circuit analyses, sampling, charging, and venting. The p/T version can be used to measure pressures and temperatures at a single measuring point at the same time.</p>	<p>1620 series – Pages 12 - 13</p> 	<p>1620 p/T series – Page 14</p> 	<p>1615 series – Page 15</p> 	<p>1215 series – Pages 16 - 17</p> 	<p>1604 series – Page 19</p> 
<p>ORIGINAL MINIMESS^{XTREME} TEST POINTS Pressures of up to 1,000 bar, immersion depths of up to 5,000 m, and temperatures as low as -60 °C are simply a matter of course for these high-performance products. In other words, they are the product of choice for the most demanding measuring tasks out there.</p>	<p>Offshore – Page 20</p> 	<p>Deep Sea – Page 20</p> 	<p>Special Fluids – Page 20</p> 	<p>Low Temperatures – Page 21</p> 	<p>Pressure – Page 21</p> 
<p>ORIGINAL MINIMESS® GAS CHARGING VALVES AND ACCESSORIES Designed to make it easy, fast, and safe to fill, monitor, and empty gas accumulators and gas-conveying lines.</p>	<p>Gas charging valves – Page 23</p> 	<p>DVGW test point – Page 24</p> 	<p>Gas charging valve with accumulator adapter Page 25</p> 	<p>Accumulator charging and testing device Page 26</p> 	<p>Gas charging and testing device with pressure regulator Page 26</p> 
<p>ADAPTERS WITH ORIGINAL MINIMESS® TEST POINTS Used to retrofit test points on existing systems. New installations? Combining measuring points? Not a problem.</p>	<p>DKO fittings – Pages 28 - 33</p> 	<p>DKO combi fittings / tee adapters Pages 34 - 37</p> 	<p>90° swivel fittings – Page 38</p> 	<p>Bulkhead versions – Pages 39 - 40</p> 	<p>Sleeves for ORFS and 37° flared fitting Pages 41 - 42</p> 
<p>MINIMESS® GAUGE AND SENSOR ADAPTERS, HOSE LINES, AND ACCESSORIES Connect your pressure gauges and sensors directly to your test point or use one of our MINIMESS® hose lines. In addition, this group includes hose materials parts designed for the MINIMESS® Xtreme.</p>	<p>Gauge and sensor adapters – Pages 43 - 45</p> 	<p>Hose lines – Pages 47 - 56</p> 	<p>Gauge and sensor adapters for bulkheads – Page 57</p> 		
<p>EXPANDED MINIMESS® PORTFOLIO Special solutions for your technical fluid applications that are designed to complement our range of traditional MINIMESS® products.</p>	<p>Minivalv throttle check valve Page 58</p> 	<p>Flat Face diagnostic couplings Page 59</p> 	<p>Test couplings for air brake systems – Page 59</p> 		

Original MINIMESS® test points

The benchmark for test couplings

MINIMESS® test points serve as system access points for analyses and tests in fluid circuits, and can be used to make a leak-tight connection under pressure. This makes it possible to connect sensors or pressure gauges or draw samples as necessary without any downtimes. Moreover, the test points can be used to fill, vent, and empty systems.

Original MINIMESS® test points

- | Are an integral part of measuring and testing equipment
- | Can be used to make leak-tight connections under pressure
- | Open and close automatically when a hose or sensor is connected / disconnected
- | Save time and money by making diagnostics and maintenance faster, improving machine availability as a result
- | Save money by ensuring that expensive sensors do not have to be permanently installed for servicing purposes
- | Conform to ISO 15171-2 (MINIMESS® 1620)
- | Have a four-fold safety factor in regard to bursting
- | Are certified with 1,000,000 pressure pulses at 1.3 times the operating pressure
- | Can also be used at low temperatures
- | Are highly resistant to corrosion (salt spray test longer than 1,000 hours)
- | Are suitable, without restrictions, for HL-, HLP, HVLP hydraulic fluids in conformity with DIN 51524

The **original MINIMESS® 1620 p/T test point** is a multipurpose test point that can be used to simultaneously measure pressure and temperature at a single measuring point. As a result, the number of required measuring points can be reduced by up to 50%.

The temperature is measured directly in the flowing fluid, resulting in extremely short response times.

For information on compatible **HySense®** p/T combo sensors, please refer to page 144.

Test point	Screw cap thread	Nominal diameter	Max. operating pressure ¹	Material selection	Seal materials
MINIMESS® 1620	M16x2	DN2	630 bar	1.0718 free cutting steel	NBR (Perbunan)
MINIMESS® 1620 p/T	M16x2	DN2	630 bar		
MINIMESS® 1615	M16x1.5	DN2	630 bar	1.4571 stainless steel	FKM (Viton)
MINIMESS® 1215	Buttress thread 12	DN2	630 bar		
MINIMESS® 1604	Buttress thread 16	DN4	400 bar		

Additional materials and seal materials available upon request.
¹ Depends on the size of the stud end.



Original MINIMESS® 1620 test point

The MINIMESS® 1620 test point with an M16 x 2 thread is the top seller among test couplings and is used for most standard applications. It can be used with operating pressures of up to 630 bar and is available in a wide variety of versions with various international threads and seal types.

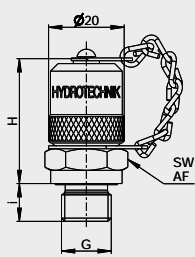

Version with metal cap

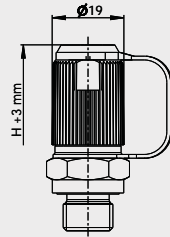

Version with plastic cap

Seal types

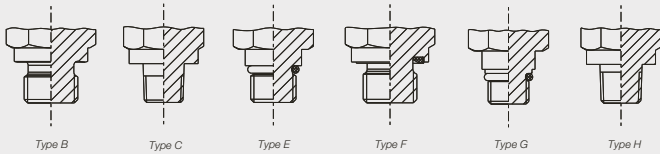

Thread	Seal type ¹	Technical specifications					Material: 1.0718 free cutting steel	Material: 1.4571 Stainless steel
		M ² Nm	p _o ³ bar	H mm	i mm	AF mm	Part No. with metal cap & NBR seals	Part No. with metal cap & FKM seals
Metric ISO thread								
M10 x 1	E	20	630	37.5	9.5	17	2103-01-94.00N	–
M10 x 1	F	20	400	37.6	8	17	2103-01-12.00N	2703-01-12.10
M10 x 1	G	15	630	37.5	8.5	17	2103-01-33.00N	2703-01-33.10
M12 x 1.5	B	45	630	36	10	17	2103-01-48.00N	–
M12 x 1.5	E	35	630	35.1	11	17	2103-01-95.00N	–
M12 x 1.5	F	45	630	36	10	17	2103-01-13.00N	2703-01-13.10
M14 x 1.5	B	60	630	36	10	19	2103-01-49.00N	–
M14 x 1.5	E	45	630	35.5	11	19	2103-01-96.00N	–
M14 x 1.5	F	60	630	36	10	19	2103-01-14.00N	2703-01-14.10
M16 x 1.5	F	80	630	36	10	22	2103-01-15.00N	–
Whitworth thread								
ISO 228-G 1/8	F	20	400	38	8	17	2103-01-17.00N	2703-01-17.10
ISO 228-G 1/4	B	60	630	36	10	19	2103-01-51.00N	2703-01-51.10
ISO 228-G 1/4	F	60	630	36	10	19	2103-01-18.00N	2703-01-18.10
ISO 228-G 3/8	F	90	630	36	10	22	2103-01-16.00N	2703-01-16.10
UNF thread								
7/16-20 UNF	E	20	630	37	11	17	2103-01-B5.00N	2703-01-B5.10
9/16-18 UNF	E	35	630	36	12	17	2103-01-B6.00N	2703-01-B6.10
Tapered thread								
ISO 7/1-R 1/8	C	–	400	33	13	17	2103-01-40.00N	–
ISO 7/1-R 1/4	C	–	630	33	13	17	2103-01-41.00N	2703-01-41.10
NPTF thread								
1/8 NPTF	H	–	400	33	9.5	17	2103-01-46.00N	–
1/4 NPTF	H	–	630	33	16.5	17	2103-01-47.00N	2703-01-47.10
Options								
Part No. with FKM seals							XXXX-XX-XX-10N	–
Part No. with plastic cap							XXXX-30-XX-XXN	XXXX-30-XX-XX
Operating temperature ranges:								
With NBR seals: -25 °C ... 100 °C / With FKM seals: -20 °C ... 200 °C / With plastic cap: Max. 100 °C								
Additional versions, materials, and seal materials available upon request.								

¹ For detailed specifications regarding the seal types, please refer to pages 62 – 64

² M – Tightening torque for stud end in conformity with the applicable standards. It is the user's own responsibility to determine the appropriate installation torque for their specific installation situation.

³ p_o = Maximum operating pressure

Original MINIMESS® 1620 p/T test point

The MINIMESS® 1620 p/T test point can be used to simultaneously measure pressure and temperature with only one single test coupling by using a p/T multipurpose sensor. This results in fewer measuring points and sensors being required.

The p/T test point can be used with operating pressures of up to 630 bar.

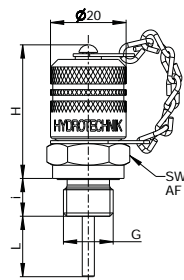

Seal types

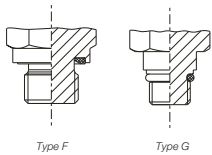

Original MINIMESS® 1615 test point

The MINIMESS® 1615 test point was developed primarily for military applications and has an alternative M16 x 1.5 coupling thread available. It can be used with operating pressures of up to 630 bar and is available with various threads.

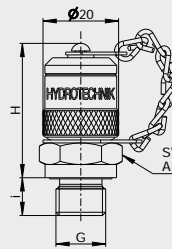

Seal types

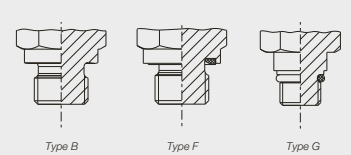

Thread	Seal type ¹	Technical specifications						Material: 1.0718 free cutting steel		Material: 1.4571 Stainless steel	
		M ² Nm	p ₀ ³ bar	H mm	i mm	L mm	AF mm	Part No. with metal cap & NBR seals	Part No. with metal cap & FKM seals		
Metric ISO thread											
M10 x 1	G	15	630	38	8.5	16	17	2149-04-19.13N	2749-04-19.53		
Whitworth thread											
ISO 228-G 1/4	F	60	630	36.5	10	16	19	2149-04-15.13N	2749-04-15.53		
Options											
Part No. with FKM seals								XXXX-XX-XX.53 ¹	-		
Part No. with EPDM seals								XXXX-XX-XX.43 ¹	-		
Operating temperature ranges:											
With NBR seals: -25 °C ... 100 °C / With FKM seals: -20 °C ... 200 °C / With EPDM seal: -40 °C ... 125 °C											
Additional versions, materials, and seal materials available upon request.											

¹ For detailed specifications regarding the seal types, please refer to pages 62 – 64

² M = Tightening torque for stud end in conformity with the applicable standards. It is the user's own responsibility to determine the appropriate installation torque for their specific installation situation.

³ p₀ = Maximum operating pressure

Thread	Seal type ¹	Technical specifications						Material: 1.0718 free cutting steel		Material: 1.4571 Stainless steel	
		M ² Nm	p ₀ ³ bar	H mm	i mm	AF mm	Part No. with metal cap & NBR seals	Part No. with metal cap & FKM seals			
Metric ISO thread											
M10 x 1	G	15	630	37.5	8.5	17	2102-01-33.00N	2702-01-33.10			
M12 x 1.5	F	45	630	36	10	17	2102-01-13.00N	2702-01-13.10			
M14 x 1.5	B	60	630	36	10	19	2102-01-49.00N	-			
M14 x 1.5	F	60	630	36	10	19	2102-01-14.00N	2702-01-14.10			
Whitworth thread											
ISO 228-G 1/8	F	20	400	38	8	17	2102-01-17.00N	-			
ISO 228-G 1/4	B	60	630	36	10	19	2102-01-51.00N	-			
ISO 228-G 1/4	F	60	630	36	10	19	2102-01-18.00N	2702-01-18.10			
Options											
Part No. with FKM seals								XXXX-XX-XX.10 ¹	-		
Operating temperature ranges: With NBR seals: -25 °C ... 100 °C / With FKM seals: -20 °C ... 200 °C											
Additional versions, materials, and seal materials available upon request.											

¹ For detailed specifications regarding the seal types, please refer to pages 62 – 64

² M = Tightening torque for stud end in conformity with the applicable standards. It is the user's own responsibility to determine the appropriate installation torque for their specific installation situation.

³ p₀ = Maximum operating pressure

Original MINIMESS® 1215 test point

The MINIMESS® 1215 test point is characterized by a small coupling thread, resulting in a very compact design. It was originally developed as an alternative test point for metrological applications in places where space is tight. The test point can be used with operating pressures of up to 630 bar and is available with various international threads and seal types.

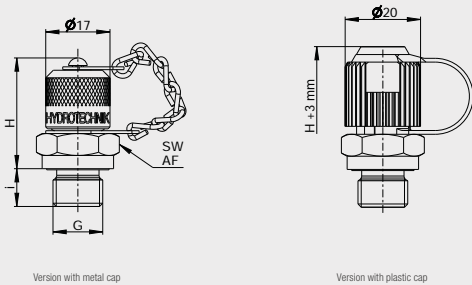

Version with metal cap

Version with plastic cap

Seal types

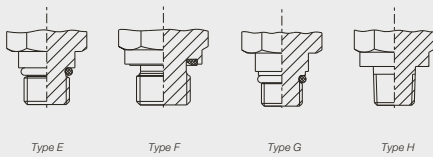

Type E

Type F

Type G

Type H

Thread	Seal type ¹	Technical specifications					Material: 1.0718	Material: 1.4571
		M ² Nm	p _o ³ bar	H mm	i mm	AF mm	free cutting steel	Stainless steel
		Part No.		Part No.				
		with metal cap & NBR seals		with metal cap & FKM seals				
Metric ISO thread								
M10 x 1	G	15	630	30	8.5	14	2101-06-33.00N	2701-06-33.10
M12 x 1.5	E	35	630	29	11	17	2101-06-76.00N	–
M12 x 1.5	F	45	630	29	10	17	2101-06-13.00N	–
M14 x 1.5	E	45	630	29	11	19	2101-06-96.00N	–
M14 x 1.5	F	60	630	29	10	19	2101-06-14.00N	–
Whitworth thread								
ISO 228-G 1/8	F	20	400	30	8	14	2101-06-17.00N	2701-06-17.10
ISO 228-G 1/4	F	60	630	29	10	19	2101-06-18.00N	2701-06-18.10
UNF thread								
7/16-20 UNF	E	20	630	29	11	17	2101-06-B5.00N	2701-06-B5.10
9/16-18 UNF	E	35	630	28	12	17	2101-06-B6.00N	–
Tapered thread								
1/8 NPTF	H	–	400	26	12	14	2101-06-46.00N	2701-06-46.10
1/4 NPTF	H	–	630	26	15	14	2101-06-47.00N	2701-06-47.10
Options								
Part No. with FKM seals							XXXX-XX-XX10N	–
Part No. with plastic cap							XXXX-01-XXXN	XXXX-01-XXX
Operating temperature ranges: With NBR seals: -25 °C ... 100 °C / With FKM seals: -20 °C ... 200 °C / With plastic cap: Max. 100 °C								
Additional versions, materials, and seal materials available upon request.								

¹ For detailed specifications regarding the seal types, please refer to pages 62 – 64

² M = Tightening torque for stud end in conformity with the applicable standards. It is the user's own responsibility to determine the appropriate installation torque for their specific installation situation.

³ p_o = Maximum operating pressure



MINIMESS®

Original MINIMESS® 1604 test point

The MINIMESS® 1604 test point is particularly suitable for quickly filling or emptying systems as a result of its nominal diameter of DN4.

The test point can be used with operating pressures of up to 400 bar and is available with various threads.

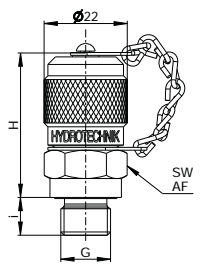

Seal types

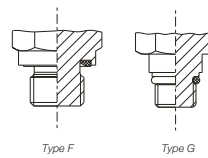

Thread	Seal type ¹	Technical specifications					Material: 1.0718 free cutting steel	Material: 1.4571 Stainless steel
		M ² Nm	p ₁ ³ bar	H mm	i mm	AF mm	Part No. with metal cap & NBR seals	Part No. with metal cap & FKM seals
Metric ISO thread								
M10 x 1	G	15	400	43	8.5	17	2106-01-33.00N	–
M12 x 1.5	F	45	400	40	10	17	2106-01-13.00N	–
M14 x 1.5	F	60	400	40	10	19	2106-01-14.00N	–
Whitworth thread								
ISO 228-G 1/4	F	60	400	40	10	19	2106-01-18.00N	2706-01-18.10
Options								
Part No. with FKM seals							XXXX-XX-XX-10N	–
Operating temperature ranges: With NBR seals: -25 °C ... 100 °C / With FKM seals: -20 °C ... 200 °C								
Additional versions, materials, and seal materials available upon request.								

¹ For detailed specifications regarding the seal types, please refer to pages 62 – 64

² M = Tightening torque for stud end in conformity with the applicable standards. It is the user's own responsibility to determine the appropriate installation torque for their specific installation situation.

³ p₁ = Maximum operating pressure

Original MINIMESS Xtreme® test points for liquids and gases

Offshore

MINIMESS® Offshore series test points and gas charging valves were developed for direct contact with salt water, and their premium stainless steel construction enables them to withstand the extreme environmental conditions present at sea.

- | Body, internal parts, and cap made of corrosion-resistant 1.4571 stainless steel
- | Can be used with temperatures as low as -40 °C
- | Splash-proof



Deep Sea

MINIMESS® Deep Sea series test points and gas charging valves are designed for high ambient pressures of up to 500 bar. Moreover, their special construction makes it possible to use them safely at deep depths by reliably preventing the ingress of salt water.

- | Designed to withstand ambient pressures of up to 500 bar and depths of up to 5,000 meters
- | Body, internal parts, and cap made of corrosion-resistant 1.4571 stainless steel
- | Absolutely no leaks when subjected to internal and ambient pressure



Fluids

MINIMESS® test points for special fluids are characterized by high chemical and thermal resistance. This is particularly important for the chemical, aviation, and vehicle manufacture industries, which use fluids that entail special requirements for seal materials. It also means that **MINIMESS®** test points for special media can be used for an extremely wide variety of applications.

- | High chemical resistance against aviation hydraulic fluid (Skydrol®), brake fluid (DOT3 to DOT5), etc.
- | High resistance to temperatures of up to more than 300 °C when using special FFKM seals
- | Available with a free cutting steel or stainless steel body



Low Temperature

MINIMESS® low-temperature test points, which are made of stainless steel, can be used at extremely low temperatures. The secret consists of special seal materials that ensure safe and reliable sealing under extreme cold conditions.

- | Can be used with temperatures as low as -60 °C
- | Premium-grade elastomers
- | We also have compatible low-temperature hoses available



Pressure

The new **MINIMESS®** high-pressure test point combines all the characteristics of our classic **MINIMESS®** test points with a significantly higher pressure resistance. The test point is tested with four times its maximum operating pressure in order to guarantee the safety of its users.

- | Operating pressures of up to 1,000 bar
- | Burst pressure > 4,000 bar
- | Long service life: > 1,000,000 pressure pulses at 1,330 bar



Original MINIMESS® gas charging valves and accessories

Original MINIMESS® gas charging valves are designed to make it easy and fast to fill, empty, and test hydraulic accumulators. Moreover, they can be used as system access points for maintenance, monitoring, and analysis tasks on gas-conveying systems.

On top of this, extraordinarily low leakage flow rates make MINIMESS® gas charging valves the ideal choice for long-term use in systems with extremely demanding safety requirements as well.

Original MINIMESS® gas charging valves

- I Feature extraordinary gas tightness with a leakage flow rate $< 2 \cdot 10^{-5}$ mbar-l/s (He) within a permissible temperature range of -20 °C to 135 °C
- I Can be used to make connections under pressure
- I Open and close automatically when a charging device or sensor is connected / disconnected
- I Save time and money by making diagnostics and maintenance faster, improving machine availability as a result
- I Save money by ensuring that expensive sensors do not have to be permanently installed for servicing purposes
- I Have a four-fold safety factor in regard to bursting
- I Can also be used at low temperatures
- I Are made of corrosion-resistant stainless steel
- I Are suitable for all inert gases

Original MINIMESS® 1615 gas charging valve

The original MINIMESS® 1615 gas charging valve is designed specifically for use with inert gases and features an extraordinary low gas leakage flow rate of less than $2 \cdot 10^{-5}$ mbar-l/s (He). It can be used with operating pressures of up to 630 bar and is available with various threads.

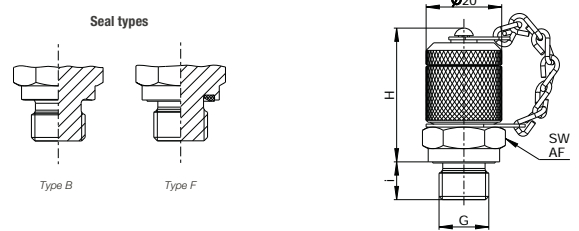

Thread	Seal type ¹	Technical specifications					Material: 1.4104 Stainless steel		Material: 1.4571 Stainless steel	
		M ² Nm	p ₁ ³ bar	H mm	I mm	AF mm	Part No. with metal cap & FKM seals	Part No. with metal cap & FKM seals		
Metric ISO thread										
M12 x 1.5	F	45	630	36	10	17	–	2402-01-13.50		
M14 x 1.5	B	60	630	36	10	19	2402-01-49.00*	2402-01-49.30**		
M14 x 1.5	F	60	630	36	10	19	2402-01-14.00	–		
Whitworth thread										
ISO 228-G 1/4	F	60	630	36	10	19	2402-01-18.00	–		
Operating temperature ranges: -20 °C ... 135 °C / * -33 °C ... 135 °C / ** -46 °C ... 135 °C										
Additional versions, materials, and seal materials available upon request.										

¹ For detailed specifications regarding the seal types, please refer to pages 62 – 64

² M = Tightening torque for stud end in conformity with the applicable standards. It is the user's own responsibility to determine the appropriate installation torque for their specific installation situation.

³ p₁ = Maximum operating pressure

Original MINIMESS® 1215 gas charging valve with DVGW certification

The original MINIMESS® 1215 DVGW gas charging valve can be used to establish a system access point for gas pressure regulating stations and connect control measuring devices for pressure measurement and gas sampling as specified in DVGW Code of Practice G 491, Section 5.7.1. It can be used with operating pressures of up to 250 bar and is characterized by a small coupling thread resulting in a very compact design and an extraordinary low gas leakage flow rate of less than $2 \cdot 10^{-5}$ mbar-l/s.

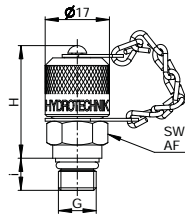

- I DVGW certification for: Products for gas supply applications
- I Registration number: DG-4513BL0337
- Certificate owner and distributor: Hydrotechnik GmbH



Original MINIMESS® 1615 gas charging valve with accumulator adapter

The original MINIMESS® 1615 gas charging valve featuring an accumulator adapter can be used to directly install the valve on all popular bladder accumulators and can be used with operating pressures of up to 400 bar. This gas charging valve makes it possible to safely charge and empty accumulators with an extremely low leakage flow rate.

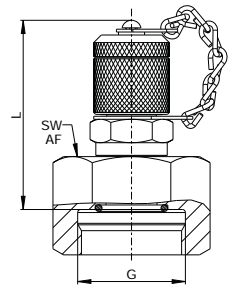

Thread	Seal type ¹	Technical specifications						Material: 2.0371 Brass		Material: 1.4571 Stainless steel	
		M ² Nm	p ₁ ³ bar	H mm	l mm	AF mm	Part No. with metal cap & NBR seals	Part No. with metal cap & NBR seals			
G											
M10 x 1	G	15	250	30	8.5	14	2801-66-33.00	2701-66-33.00			

Operating temperature range: -20 °C ... 70 °C

Additional versions available upon request.

¹ For detailed specifications regarding the seal types, please refer to pages 62 – 64

² M = Tightening torque for stud end in conformity with the applicable standards. It is the user's own responsibility to determine the appropriate installation torque for their specific installation situation.

³ p₁ = Maximum operating pressure

Female thread	Technical specifications				Material:	
	p ₁ ¹ bar	L mm	AF mm	Gas charging valve: 1.4104 stainless steel	Accumulator adapter: 1.0718 free cutting steel	
G						
7/8-14 UNF	400	59.3	30		2446-16-30.00	
M28 x 1.5	400	50.6	36		2446-18-30.00	

Operating temperature range: -25 °C ... 100 °C

Additional versions, materials, and seal materials available upon request.

¹ p₁ = Maximum operating pressure

MINIMESS® accumulator charging and testing device

The **MINIMESS®** accumulator charging and testing device can be used to charge and test multiple accumulators without having to close the pressure source (usually a nitrogen cylinder).

The pressure in the charging and testing device can be relieved after closing the nitrogen cylinder by opening the relief valve.

In contrast to devices for which the pressure source needs to be closed after every charging operation, the **MINIMESS®** accumulator charging and testing device can be used to charge or test multiple accumulators, saving time and cutting costs as a result.



Adapter options with original MINIMESS® test points

Special installation situations, grouping together multiple measuring points at a central location, or retrofitting into existing systems – all child's play with the various fitting and adapter options for **MINIMESS®** test points.

Adapter option examples:

Combi fitting tees make it possible to retrofit or install **MINIMESS®** test points on hydraulic system pipes and hose lines. They have a 360° swivel range, meaning that they can adapt optimally to an extremely broad range of installation conditions.

Combi fitting tees are available with 24° sealing cone and O-ring (DKO) connections in conformity with ISO 8434-1 as standard.

Upon request, versions with a 37° flared fitting in conformity with ISO 8434-2, with an ORFS connector as per ISO 8434-3, or with a 60° cone as per ISO 8434-6 are available.



MINIMESS® bulkhead test points can be used, for example, to group together multiple test points at an easily accessible location, making maintenance easier as a result.



Gas charging and testing device with pressure regulator

Premium quality. Made in Germany. For charging, adjusting, and monitoring gas pressures in nitrogen hydraulic accumulators and featuring pressure gauges with a diameter of 63 mm and accuracy class 1.6.



Secondary pressure setting bar	Primary pressure setting bar	Cylinder connection thread	Secondary connection	AF mm	Part No.
10 – 235	0 – 250	W 24.32 x 1/14"	MINIMESS® 1615	28	5401-02-00.00
10 – 235	0 – 250	W 21.8 x 1/14"	MINIMESS® 1615	28	5401-02-02.00
0 – 1.3	0 – 1.6	W 24.32 x 1/14"	MINIMESS® 1615	28	5401-07-00.00

Original MINIMESS® 1620 test point with DKO fitting

MINIMESS® test points with fittings for 24° sealing cone fittings with an O-ring make it possible to easily use the test points in systems with sealing cone connections that conform to DIN 2353 / ISO 8434-1.

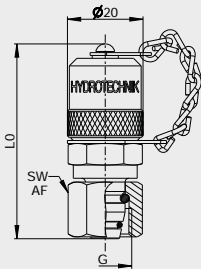

Figure 1

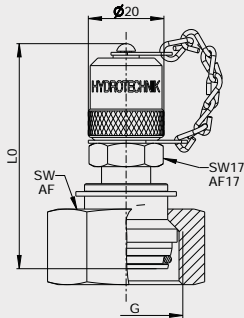
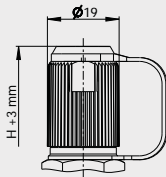

Figure 2



Version with plastic cap

Series	Thread	Technical specifications			Material: 1.0718 free cutting steel		Material: 1.4571 Stainless steel	
		pe ¹ bar	L0 mm	AF mm	Part No. with metal cap & NBR seals ²	Part No. with metal cap & FKM seals		
Light series, designed in conformity with					Figure 1		Figure 2	
L 6	M12 x 1.5	315	52	14	2103-93-06.00N	2703-40-06.10		
L 8	M14 x 1.5	315	52	17	2103-93-08.00N	2703-40-08.10		
L 10	M16 x 1.5	315	52	19	2103-93-10.00N	2703-40-10.10		
L 12	M18 x 1.5	315	52	22	2103-93-12.00N	2703-40-12.10		
L 15	M22 x 1.5	315	52	27	2103-93-15.00N	2703-40-15.10		
L 18	M26 x 1.5	315	52	32	2103-93-18.00N	2703-40-18.10		
Light series, designed in conformity with					Figure 2			
L 22	M30 x 2	160	60	36	2103-40-22.00N			
L 28	M36 x 2	160	61	41	2103-40-28.00N			
L 35	M45 x 2	160	63	50	2103-40-35.00N			
L 42	M52 x 2	160	63	60	2103-40-42.00N			
Heavy series, designed in conformity with					Figure 1		Figure 2	
S 6	M14 x 1.5	630	52	17	2103-94-06.00N			
S 8	M16 x 1.5	630	52	19	2103-94-08.00N	2703-41-08.10		
S 10	M18 x 1.5	630	52	22	2103-94-10.00N	2703-41-10.10		
S 12	M20 x 1.5	630	52	24	2103-94-12.00N	2703-41-12.10		
S 16	M24 x 1.5	400	52	30	2103-94-16.00N	2703-41-16.10		
Heavy series, designed in conformity with					Figure 2			
S 14	M22 x 1.5	630	63	27	2103-41-14.00N			
S 20	M30 x 2	400	63	36	2103-41-20.00N	2703-41-20.10		
S 25	M36 x 2	400	64.5	46	2103-41-25.00N	2703-41-20.10		
S 30	M42 x 2	400	66	50	2103-41-30.00N			
S 38	M52 x 2	400	69	60	2103-41-38.00N	2703-41-38.10		
Options								
Part No. with FKM seals					XXXX-XX-XX	10		
Part No. with plastic cap					XXXX-XX-XX	90		
Part No. with plastic cap & FKM seals					XXXX-XX-XX	95		XXXX-XX-XX 95

¹ pe = Maximum operating pressure

² Seal on DKO fitting made of FKM

Operating temperature ranges: With NBR seals: -25 °C ... 100 °C / With FKM seals: -20 °C ... 200 °C / With plastic cap: Max. 100 °C
Additional versions, materials, and seal materials available upon request.

Original MINIMESS® 1615 test point with DKO fitting

MINIMESS® test points with fittings for 24° sealing cone fittings with an O-ring make it possible to easily use the test points in systems with sealing cone connections that conform to DIN 2353 / ISO 8434-1.

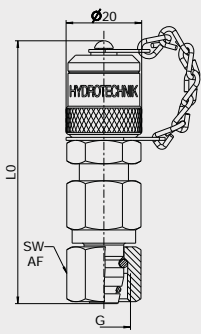

Figure 1

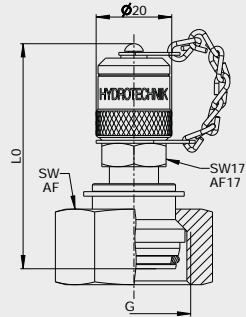

Figure 2

Series	Thread	Technical specifications			Material: 1.0718 free cutting steel Part No. with metal cap & NBR seals ²
		pn ¹ bar	L0 mm	AF mm	
Light series, designed in conformity with figure 1					
L 6	M12 x 1.5	315	69.5	14	2102-40-06.00N
L 8	M14 x 1.5	315	69.5	17	2102-40-08.00N
L 10	M16 x 1.5	315	69.5	19	2102-40-10.00N
L 12	M18 x 1.5	315	69.5	22	2102-40-12.00N
Light series, designed in conformity with figure 2					
L 15	M22 x 1.5	315	59	27	2102-40-15.00N
Heavy series, designed in conformity with figure 1					
S 8	M16 x 1.5	630	69.5	19	2102-41-08.00N
S 12	M20 x 1.5	630	69.5	24	2102-41-12.00N
Heavy series, designed in conformity with figure 2					
S 14	M22 x 1.5	630	62.5	27	2102-41-14.00N
S 16	M24 x 1.5	400	62.5	30	2102-41-16.00N
S 20	M30 x 2	400	63	36	2102-41-20.00N
S 25	M36 x 2	400	64.5	46	2102-41-25.00N
Options					
Part No. with FKM seals					XXXX-XX-XX.10N

¹ pn = Maximum operating pressure

² Seal on DKO fitting made of FKM

Operating temperature ranges: With NBR seals: -25 °C ... 100 °C / With FKM seals: -20 °C ... 200 °C
Additional versions, materials, and seal materials available upon request.

Original MINIMESS® 1215 test point with DKO fitting

MINIMESS® test points with fittings for 24° sealing cone fittings with an O-ring make it possible to easily use the test points in systems with sealing cone connections that conform to DIN 2353 / ISO 8434-1.

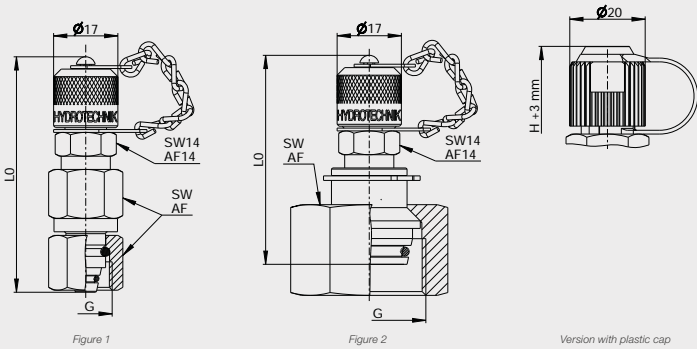

Series	Thread	Technical specifications			Material: 1.0718 free cutting steel
		pn ¹ bar	L0 mm	AF mm	
0 0	G				Part No. with metal cap & NBR seals ²
Light series, designed in conformity with figure 1					
L 6	M12 x 1.5	315	62	17	2101-40-06.90N
L 8	M14 x 1.5	315	51.5	19	2101-93-08.90N
L 10	M16 x 1.5	315	51.5	19	2101-93-10.90N
L 12	M18 x 1.5	315	62	22	2101-40-12.90N
Light series, designed in conformity with figure 2					
L 15	M22 x 1.5	315	51.5	27	2101-93-15.90N
L 18	M26 x 1.5	315	52.5	32	2101-40-18.90N
Heavy series, designed in conformity with figure 1					
S 6	M14 x 1.5	630	62	17	2101-41-06.90N
S 8	M16 x 1.5	630	51.5	19	2101-94-08.90N
S 10	M18 x 1.5	630	51.5	22	2101-94-10.90N
S 12	M20 x 1.5	630	58	24	2101-94-12.90N
Heavy series, designed in conformity with figure 2					
S 14	M22 x 1.5	630	55	27	2101-41-14.90N
S 16	M24 x 1.5	400	55	30	2101-41-16.90N
S 20	M30 x 2	400	55.5	36	2101-41-20.90N
Options					
Part No. with plastic cap and FKM seals					XXXX-XX-XX.10N
Part No. with plastic cap and NBR seals					XXXX-XX-XX.00N

¹ pn – Maximum operating pressure

² Seal on DKO fitting made of FKM

Operating temperature ranges: With NBR seals: -25 °C ... 100 °C / With FKM seals: -20 °C ... 200 °C / With plastic cap: Max. 100 °C
Additional versions, materials, and seal materials available upon request.

Original MINIMESS® 1620 test point with DKO combi fitting tee

MINIMESS® test points with 24° sealing cone and O-ring combi fitting tees can be easily retrofitted and used on existing systems with sealing cone connections that conform to DIN 2353 / ISO 8434-1.

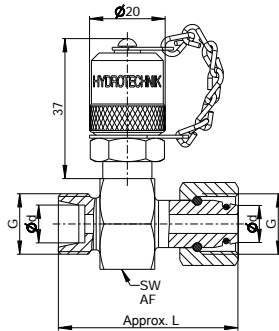

Original MINIMESS® 1620 test point with tee adapter

MINIMESS® test points with a tee adapter can be easily retrofitted and used on existing piping systems as a result of a cutting ring fitting that conforms to DIN 2353 / ISO 8434-1.

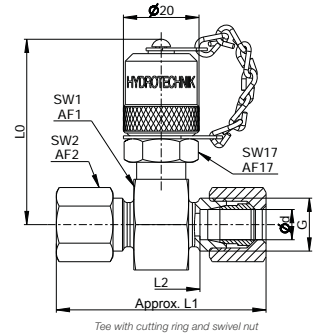

Series	Thread	Technical specifications				Material: 1.0718 free cutting steel
Ø D	G	p _{h1} bar	L0 mm	L mm	AF mm	Part No. with metal cap & NBR seals ²
Light series version						
L 6	M12 x 1.5	315	49	44.5	24	2103-KL-10.06N
L 8	M14 x 1.5	315	49	44.5	24	2103-KL-08.00N
L 10	M16 x 1.5	315	49	47.5	24	2103-KL-10.00N
L 12	M18 x 1.5	315	49	48.5	24	2103-KL-12.00N
L 15	M22 x 1.5	315	52	51.5	30	2103-KL-15.00N
L 18	M26 x 1.5	315	53	55.5	32	2103-KL-18.00N
L 22	M30 x 2	160	22	58.5	36	2103-KL-22.00N
Heavy series version						
S 8	M16 x 1.5	630	49	48.5	24	2103-KS-08.00N
S 10	M18 x 1.5	630	49	49.5	24	2103-KS-10.00N
S 12	M20 x 1.5	630	50.5	50.5	27	2103-KS-12.00N
S 14	M22 x 1.5	630	51	53.5	27	2103-KS-14.00N
S 16	M24 x 1.5	400	52	56.5	30	2103-KS-16.00N
S 20	M30 x 2	400	55	64.5	36	2103-KS-20.00N
S 25	M36 x 2	400	57.5	66	41	2103-KS-25.00N

¹ p_{h1} = Maximum operating pressure

² Seal on DKO fitting made of FKM

Operating temperature range: -25 °C ... 100 °C

Additional versions, materials, and seal materials available upon request. DKO combination fitting with test points from the 1615 or 1604 series available upon request.

Series	Thread	Technical specifications						Material: 1.0718 free cutting steel	
Ø D	G	p _{h1} bar	L0 mm	L1 mm	L2 mm	SW1 mm	SW2 mm	Version: With metal cap & NBR seals Part No. with cutting ring and swivel nut	Part No. without cutting ring and swivel nut
Light series version									
L 6	M12 x 1.5	315	49.5	50.5	20.5	24	14	2103-11-06.00N	2103-11-06.05N
L 8	M14 x 1.5	315	49.5	50.5	20.5	24	17	2103-11-08.00N	2103-11-08.05N
L 10	M16 x 1.5	315	49.5	52.5	22.5	24	19	2103-11-10.00N	2103-11-10.05N
L 12	M18 x 1.5	315	49.5	52.5	22.5	24	22	2103-11-12.00N	2103-11-12.05N
L 15	M22 x 1.5	315	52.5	54.5	24.5	30	27	2103-11-15.00N	2103-11-15.05N
L 18	M26 x 1.5	315	53.5	56.5	23.5	32	32	2103-11-18.00N	2103-11-18.05N
L 22	M30 x 2	160	55.5	60.5	27.5	36	36	2103-11-22.00N	2103-11-22.05N
L 28	M36 x 2	160	58	60.5	27.5	41	41	2103-11-28.00N	2103-11-28.05N
Heavy series version									
S 6	M14 x 1.5	630	49.5	54.5	24.5	24	17	2103-12-06.00N	2103-12-06.05N
S 8	M16 x 1.5	630	49.5	54.5	24.5	24	19	2103-12-08.00N	2103-12-08.05N
S 10	M18 x 1.5	630	49.5	56.5	23.5	24	22	2103-12-10.00N	2103-12-10.05N
S 12	M20 x 1.5	630	49.5	56.5	23.5	24	24	2103-12-12.00N	2103-12-12.05N
S 14	M22 x 1.5	630	51	62.5	26.5	27	27	2103-12-14.00N	2103-12-14.05N
S 16	M24 x 1.5	400	52.5	62.5	25.5	30	30	2103-12-16.00N	2103-12-16.05N
S 20	M30 x 2	400	55.5	68.5	25.5	36	36	2103-12-20.00N	2103-12-20.05N
S 25	M36 x 2	400	58	74.5	26.5	41	46	2103-12-25.00N	2103-12-25.05N

¹ p_{h1} = Maximum operating pressure

Operating temperature range: -25 °C ... 100 °C

Additional versions, materials, and seal materials available upon request. Tees with test points from the 1615 or 1604 series available upon request.

Original MINIMESS® 1215 test point with DKO combi fitting tee

MINIMESS® test points with 24° sealing cone and O-ring combi fitting tees can be easily retrofitted and used on existing systems with sealing cone connections that conform to DIN 2353 / ISO 8434-1.

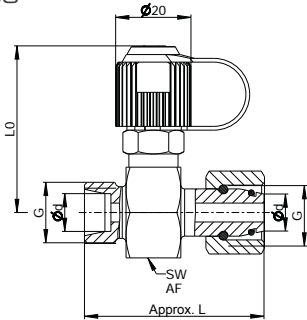

Original MINIMESS® 1215 test point with tee adapter

MINIMESS® test points with a tee adapter can be easily retrofitted and used on existing piping systems as a result of a cutting ring fitting that conforms to DIN 2353 / ISO 8434-1.

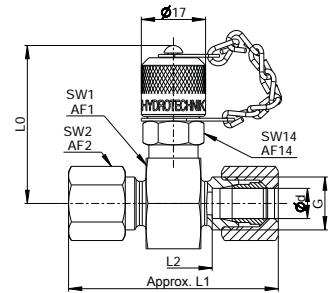

Series	Thread	Technical specifications				Material: 1.0718 free cutting steel
Ø D	G	p ₁ ¹ bar	L0 mm	L mm	AF mm	Part No. with plastic cap & NBR seals ²
Light series version						
L 6	M12 x 1.5	315	45	44.5	24	2101-KL-06.00N
L 8	M14 x 1.5	315	45	44.5	24	2101-KL-08.00N
L 10	M16 x 1.5	315	45	47.5	24	2101-KL-10.00N
L 12	M18 x 1.5	315	45	48.5	24	2101-KL-12.00N
L 15	M22 x 1.5	315	48	51.5	30	2101-KL-15.00N
L 18	M26 x 1.5	315	49	55.5	32	2101-KL-18.00N
L 22	M30 x 2	160	51	58.5	36	2101-KL-22.00N

¹ p₁ = Maximum operating pressure

² Seal on DKO fitting made of FKM

Operating temperature range: -25 °C ... 100 °C

Additional versions, materials, and seal materials available upon request. DKO combination fitting with test points from the 1615 or 1604 series available upon request.

Series	Thread	Technical specifications						Material: 1.0718 free cutting steel
Ø D	G	p ₁ ¹ bar	L0 mm	L1 mm	L2 mm	SW1 mm	SW2 mm	Part No. with metal cap & NBR seals
Light series version								
L 6	M12 x 1.5	315	42	50.5	20.5	24	14	2101-11-06.90N
L 8	M14 x 1.5	315	42	50.5	20.5	24	17	2101-11-08.90N
L 10	M16 x 1.5	315	42	52.5	22.5	24	19	2101-11-10.90N
L 12	M18 x 1.5	315	42	52.5	22.5	24	22	2101-11-12.90N
L 15	M22 x 1.5	315	45	54.5	24.5	30	27	2101-11-15.90N
L 18	M26 x 1.5	315	46	56.5	23.5	32	32	2101-11-18.90N
L 22	M30 x 2	160	48	60.5	27.5	36	36	2101-11-22.90N
L 28	M36 x 2	160	50.5	60.5	27.5	41	41	2101-11-28.90N
Heavy series version								
S 6	M14 x 1.5	630	42	54.5	24.5	24	17	2101-12-06.90N
S 8	M16 x 1.5	630	42	54.5	24.5	24	19	2101-12-08.90N
S 10	M18 x 1.5	630	42	56.5	23.5	24	22	2101-12-10.90N
S 12	M20 x 1.5	630	42	56.5	23.5	24	24	2101-12-12.90N
S 14	M22 x 1.5	630	43.5	62.5	26.5	27	27	2101-12-14.90N
S 16	M24 x 1.5	400	45	62.5	25.5	30	30	2101-12-16.90N
S 20	M30 x 2	400	48	68.5	25.5	36	36	2101-12-20.90N
S 25	M36 x 2	400	50.5	74.5	26.5	41	46	2101-12-25.90N

¹ p₁ = Maximum operating pressure

Operating temperature range: -25 °C ... 100 °C

Additional versions, materials, and seal materials available upon request. Tees with test points from the 1615 or 1604 series available upon request.

Original MINIMESS® test point with 90° swivel fitting.

The swivel fitting makes it possible to adjust the test point position exactly as required for installation. In fact, the MINIMESS® can swivel 360° about the hole axis, making it easy to position it optimally.

A DKA sealing ring is used for sealing at the thread (banjo bolt).

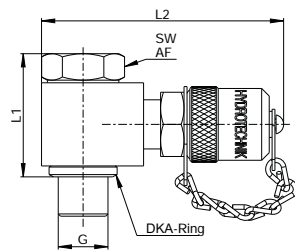

Original MINIMESS® 1620 bulkhead test point

MINIMESS® bulkhead test points can be used to group together multiple measuring points at a central system servicing point. This results in significantly easier maintenance when used to replace a large number of test points that are difficult to access.

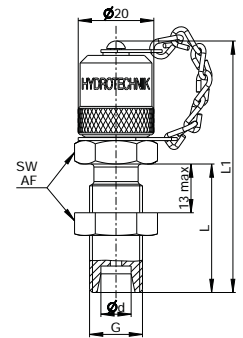

Thread	Technical specifications				Material: 1.0718 free cutting steel Part No. with metal cap & NBR seals
G	p ¹ bar	L1 mm	L2 mm	AF mm	
MINIMESS® 1620					
ISO 228-G 1/4	630	34.5	64.5	19	2115-22-34.00N
MINIMESS® 1615					
ISO 228-G 1/4	630	34.5	69.5	19	2115-22-24.00N
MINIMESS® 1215					
ISO 228-G 1/4	630	34.5	46	19	2115-22-14.00N
Options					
Part No. with FKM seals					XXXX-XX-XX-10N

¹ p₀₁ = Maximum operating pressure

Operating temperature ranges: With NBR seals: -25 °C ... 100 °C / With FKM seals: -20 °C ... 200 °C
Additional versions, materials, and seal materials available upon request.

Series	Thread	Technical specifications				Material: 1.0718 free cutting steel Part No. with metal cap & NBR seals
Ø D	G	p ¹ bar	L mm	L1 mm	AF	
Light series version						
L 6	M12 x 1.5	315	34	67	17	2103-04-22.00N
L 8	M14 x 1.5	315	34	67	19	2103-04-23.00N
L 10	M16 x 1.5	315	33.5	66.5	22	2103-04-18.00N
Heavy series version						
S 6	M14 x 1.5	630	36	69	19	2103-04-24.00N
S 8	M16 x 1.5	630	33.5	66.5	22	2103-04-25.00N
S 10	M18 x 1.5	630	37	70	24	2103-04-26.00N

¹ p₀₁ = Maximum operating pressure

Operating temperature range: -25 °C ... 100 °C

Additional versions, materials, and seal materials available upon request. 1215, 1615, and 1604 series bulkhead test points available upon request.

Original **MINIMESS®** bulkhead test points with **MINIMESS®** connection on both sides.

Bulkhead test points with a **MINIMESS®** connection on both sides can be used to group together multiple measuring points at a central system servicing point by using **MINIMESS®** hose lines.

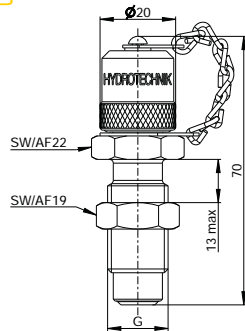

Original **MINIMESS®** 1620 test point with 37° flared fitting

MINIMESS® test points with a connection for a 37° flared fitting in conformity with SAE J514 can be used for direct connections to compatible pipes.

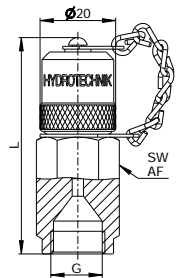

Connection	Thread		Material: 1.0718 free cutting steel Part No. with metal cap & NBR seals
	G	p _n ¹ bar	
MINIMESS® 1620 on both sides	M16 x 2	630	2103-04-16.00N
MINIMESS® 1615 on both sides	M16 x 1.5	630	2102-04-01.00N

¹ p_n = Maximum operating pressure
Operating temperature range: -25 °C ... 100 °C

Thread	Technical specifications					Material: 1.0718 free cutting steel Part No. with metal cap & NBR seals
	G	p _n ¹ bar	Pipe diameter mm	Pipe diameter Inches	L mm	
7/16-20 UNF	630	6	1/4	55	17	2103-85-21.00N
9/16-18 UNF	315	10	3/8	57.5	19	2103-85-23.00N
Options						
Part No. with FKM seals						XXXX-XX-XX.10N

¹ p_n = Maximum operating pressure
Operating temperature ranges: With NBR seals: -25 °C ... 100 °C / With FKM seals: -20 °C ... 200 °C
 Additional versions, materials, and seal materials available upon request.

Original MINIMESS® 1620 test point with ORFS fitting

MINIMESS® test points with a connection for ORFS fittings in conformity with ISO 8434-3 / SAE J1453-1 can be used for direct connections to compatible ORFS fittings.

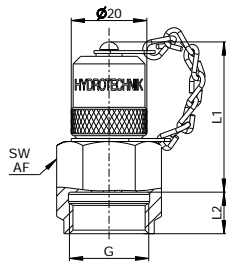

MINIMESS® direct pressure gauge and sensor adapter

The MINIMESS® direct pressure gauge and sensor adapter can be used to connect pressure sensors or gauges with various threads directly to the MINIMESS® test point.

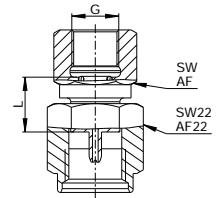

Thread	Technical specifications				Material: 1.0718 free cutting steel Part No. with metal cap & NBR seals
G	p ₀₁ ¹ bar	L1 mm	L2 mm	AF mm	
9/16-18 UNF	630	40	8	17	2103-56-10.00N
11/16-16 UN	630	40	9	22	2103-56-12.00N
13/16-16 UN	630	40	11	24	2103-56-14.00N

Options

Part No. with FKM seals

XXXX-XX-XX.101

¹p₀₁ = Maximum operating pressure

Operating temperature range: With NBR seals: -25 °C ... 100 °C / With FKM seals: -20 °C ... 200 °C
Additional versions, materials, and seal materials available upon request.

Thread	Technical specifications			Material: 1.0718 free cutting steel Part No. with pressure gauge adapter ²	Material: 1.0718 free cutting steel Part No. with pressure sensor adapter
G	p ₀₁ ¹ bar	L mm	AF mm		
MINIMESS® 1620					
ISO 228-G 1/4	630	14.5	19	2103-07-11.62N	2103-07-18.62N
ISO 228-G 1/2	630	17	27	2103-07-12.62N	–
1/4 NPT	630	–	19	2103-07-23.62N	–
MINIMESS® 1615					
ISO 228-G 1/4	630	14.5	19	2102-07-11.62N	2102-07-18.62N
ISO 228-G 1/2	630	17	27	2102-07-12.62N	–
1/4 NPT	630	–	19	2102-07-23.62N	–
MINIMESS® 1215					
ISO 228-G 1/4	630	14.5	19	2101-07-11.62N	2101-07-18.62N
ISO 228-G 1/2	630	17	27	2101-07-12.62N	–
1/4 NPT	630	–	19	2101-07-23.62N	–
MINIMESS® 1604					
ISO 228-G 1/4	630	16.5	19	2106-07-11.62N	2106-07-18.62N

¹p₀₁ = Maximum operating pressure

² For connecting pressure gauges, a nozzle is additionally installed in the body and a sealing ring is enclosed.

Operating temperature range: -25 °C ... 100 °C

Additional versions and materials available upon request.

MINIMESS® 90° direct pressure gauge and sensor adapter

The **MINIMESS®** direct pressure gauge and sensor adapter featuring a 90° elbow connection can be used to directly connect pressure sensors or gauges even in challenging installation situations.

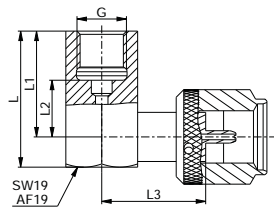

MINIMESS® Direct pressure sensor adapter

The **MINIMESS®** direct pressure sensor adapter can be used to connect pressure sensors with a G 1/4 female thread to a **MINIMESS®** test point.

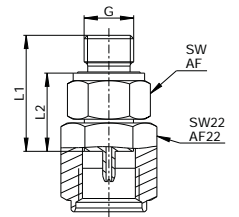

Thread		Technical specifications				Material: 1.0718 free cutting steel	
G	pn ¹ bar	L mm	L1 mm	L2 mm	L3 mm	Part No.	
MINIMESS® 1620							
ISO 228-G 1/4	630	36	28	15	27.5	2146-13-05.00N ²	
MINIMESS® 1215							
ISO 228-G 1/4	630	36	28	15	22.5	2146-14-02.00N ²	

¹ pn = Maximum operating pressure

² Part number for use with pressure sensors. For connecting pressure gauges, a nozzle is additionally installed in the body and a sealing ring is enclosed. Part number available upon request.

Operating temperature range: -25 °C ... 200 °C

Additional versions and materials available upon request.

Thread		Technical specifications			Material: 1.0718 free cutting steel	
G	pn ¹ bar	L1 mm	L2 mm	AF mm	Part No. with NBR seal	
MINIMESS® 1620						
ISO 228-G 1/4	630	30.7	20.7	19	2103-07-41.62N	
MINIMESS® 1615						
ISO 228-G 1/4	630	30.7	20.7	19	2102-07-41.62N	
MINIMESS® 1215						
ISO 228-G 1/4	630	33.5	23.5	19	2101-07-41.62N	

¹ pn = Maximum operating pressure

Operating temperature range: -25 °C ... 100 °C

Additional versions and materials available upon request.



MINIMESS®

MINIMESS® Hose lines

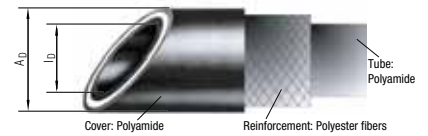

MINIMESS® hose lines make up an essential part of the **MINIMESS®** family of products. These hose lines have been developed specifically for high-pressure applications with pressures of up to 630 bar and are characterized by their resistance to aggressive fluids and a versatility that makes them ideal for use as control, diagnostic, and measuring hoses.

These hose lines can be used to conveniently group measuring points and route them to an easily accessible location in order to make maintenance and diagnostic activities easier.

They can then be combined with **MINIMESS®** bulkhead test points or pressure gauge connections for bulkheads so as to easily and quickly connect sensors or pressure gauges.

In addition to hose lines for standard hydraulic applications, we offer a variety of additional alternatives, e.g., for low-temperature and gas applications.

MINIMESS® hose lines are crimped and tested at Hydrotechnik and make an undeniably compelling case with their high quality and long service life.

Nominal diameter	Version	p_n bar	p_{dyn} bar	dp/dt bar/s	I_o mm	A_o mm	F_{min} mm	t_n °C
DN2	Standard 400, pin-pricked	400	300	3,900	2	4.9	20	-20 ... 100
DN2	Standard 630, pin-pricked	630	500	6,300	2	4.9	20	-20 ... 100
DN2	Low temperature, pin-pricked	630	500	6,300	2	4.9	20	-54 ... 100
DN4	Standard 315, pin-pricked	315	240	3,120	4	8	40	-20 ... 100
DN4	Standard 450, pin-pricked	450	340	4,420	4	8	40	-20 ... 100

- p_n = Maximum operating pressure
- p_{dyn} = Maximum operating pressure for dynamic applications
- dp/dt = Maximum permissible pressure rise time
- I_o = Inside diameter
- O_o = Outside diameter
- F_{min} = Smallest bend radius (min x 1.5 at temperatures lower than -20 °C)
- t_n = Maximum operating temperature (briefly up to 120 °C)

* The hose line's maximum permissible operating pressure always corresponds to the pressure of the individual component with the lowest permissible operating pressure.

Part No. key for MINIMESS® hose lines

Fitting material	Position in Part No. S XXX-XX-XX-XXXXN
Code 1	1.0718 free cutting steel
Code 2	1.0718 free cutting steel EPDM seals for use with brake fluid
Code 7	1.4571 stainless steel (the N ending in the part No. should be omitted in this case)

Hose version	Position in Part No. S XXX-XX-XX-XXXXN		
	Nominal diameter	pn ¹	Version
Code 0	DN2	400 bar	Standard hose, pin-pricked
Code 1	DN2	630 bar	Standard hose, pin-pricked
Code 2	DN2	630 bar	Low-temperature hose, pin-pricked
Code 5	DN4	315 bar	Standard hose, pin-pricked
Code 6	DN4	450 bar	Standard hose, pin-pricked

¹pn = Maximum operating pressure for measuring tasks
Important: The hose line's maximum permissible operating pressure always corresponds to the pressure of the individual component with the lowest permissible operating pressure.

Options	Position in Part No. S XXX-XX-XX-XXXXN
Code 0	Standard version
Code 1	Spring guard on left side
Code 2	Spring guard on right side
Code 3	Spring guards on both ends
Code 4	Aluminum armor ²

²Aluminum armor cannot be combined with a spring guard.

Fitting version ³	Position in Part No. S XXX-XX-XX-XXXXN
Left fitting	
Right fitting	

³For the fitting code, please refer to pages 50 – 57. The fitting code must be specified alphanumerically from left to right.

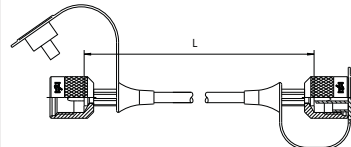
Hose length	Position in Part No. S XXX-XX-XX-XXXXN
 <p>The hose length is the distance between the two fittings.</p> <p>Specify the hose length in cm from left to right. Example: 50 cm = 0050</p>	

Part No. addition when specifying the fitting orientation:

Hoses with 90° fittings are usually assembled in such a way that the fittings will be pointing in the same direction and be aligned with each other. If customers want a different fitting orientation, they must specify it explicitly.

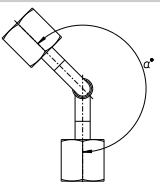
Fitting orientation	Position in Part No. S XXX XX XXX XX XXXXN
<p>The angle is always measured counterclockwise and must be specified between the two fitting codes (in this case, hyphens should be completely omitted from the Part No.).</p> <p>Order example for a hose line with DA fittings and a fitting orientation of 120°: S100DA120DA0100N</p> 	

For installation instructions for MINIMESS® hose lines, please refer to page 66.

Fittings for
MINIMESS® hose lines

MINIMESS® fitting

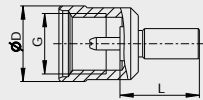

Nominal diameter	MINIMESS® fitting	Technical specifications			Fitting code
	G	p _h ¹ bar	Ø D mm	L mm	
DN2	1215	630	20	22	AA
	1615	630	20	20	AB
	1620	630	20	20	AC
DN4	1215	630	20	35	AA
	1615	630	20	35	AB
	1620	630	20	35	AC
	1604	400	22	35	AD

MINIMESS® fitting with check valve

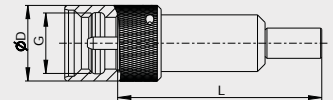

Nominal diameter	MINIMESS® fitting	Technical specifications			Fitting code
	G	p _h ¹ bar	Ø D mm	L mm	
DN2	1620	630	20	50	AR
DN4	1604	400	24	70	AY

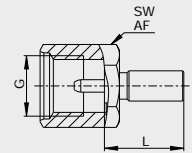

MINIMESS® fitting with hex swivel nut

Nominal diameter	MINIMESS® fitting	Technical specifications				Fitting code
	G	p _h ¹ bar	AF mm	L mm	L1 mm	
DN2	1215	630	19	38	22	AM
	1615	630	19	38	20	AN
	1620	630	19	38	20	AO

¹ p_h = Maximum operating pressure

MINIMESS® 90° fitting

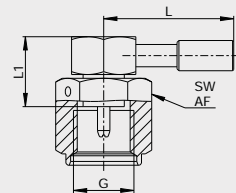

Nominal diameter	MINIMESS® fitting	Technical specifications				Fitting code
	G	p _h ¹ bar	AF mm	L mm	L1 mm	
DN2	1215	630	22	35.5	17.5	AJ
	1615	630	22	35.5	17.5	AK
	1620	630	22	35.5	17.5	AL

Fittings for MINIMESS® hose lines

Pressure gauge fitting as specified in DIN 16288 with O-ring seal

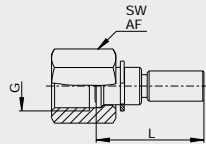

Nominal diameter	Thread	Technical specifications			Fitting code
		p_{H1} bar	AF mm	L mm	
DN2	ISO 228-G 1/4	630	17	28.5	FG
	ISO 228-G 1/2	630	27	31.5	FH

DKO fitting – 24° sealing cone with O-ring in conformity with ISO 8434-1

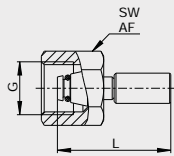

Nominal diameter	Series	Thread	Technical specifications			Fitting code
			p_{H1} bar	AF mm	L mm	
DN2/DN4	Light series					
	L 6	M12 x 1.5	315	14	30	CO
	L 8	M14 x 1.5	315	17	34	CR
	L 10	M16 x 1.5	315	19	33.5	CS
	L 12	M18 x 1.5	315	22	33.5	CT
DN2/DN4	Heavy series					
	S 6	M14 x 1.5	630	17	30	CU
	S 8	M16 x 1.5	630	19	34	CV
	S 10	M18 x 1.5	630	22	33.5	CW
	S 12	M20 x 1.5	630	24	33.5	CX

MINIMESS®

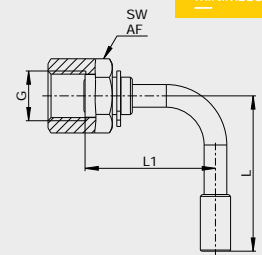

90° pressure gauge fitting as specified in DIN 16288 with O-ring seal

Nominal diameter	Thread	Technical specifications				Fitting code
		p_{H1} bar	AF mm	L mm	L1 mm	
DN2	ISO 228-G 1/4	630	17	43.5	32	FI
	ISO 228-G 1/2	630	27	43	43	FJ

90° DKO fitting – 24° sealing cone with O-ring in conformity with ISO 8434-1

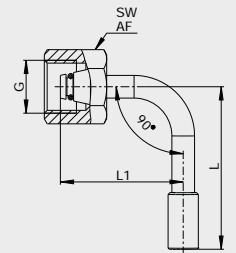

Nominal diameter	Series	Thread	Technical specifications				Fitting code
			p_{H1} bar	AF mm	L mm	L1 mm	
DN2/DN4	Light series						
	L 6	M12 x 1.5	315	14	30	32.5	DA
	L 8	M14 x 1.5	315	17	34	32.5	DB
	L 10	M16 x 1.5	315	19	33.5	37.5	DC
	L 12	M18 x 1.5	315	22	33.5	37.5	DD
DN2/DN4	Heavy series						
	S 6	M14 x 1.5	630	17	30	32.5	DE
	S 8	M16 x 1.5	630	19	34	32.5	DF
	S 10	M18 x 1.5	630	22	33.5	37.5	DG
	S 12	M20 x 1.5	630	24	33.5	37.5	DH

¹ p_{H1} = Maximum operating pressure

Fittings for
MINIMESS® hose lines

Tube stub for tube fitting in conformity with DIN 2353

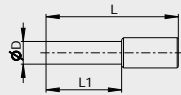

Nominal diameter	Technical specifications					Fitting code
	p ₁ ¹ bar	Ø D mm	L mm	L1 mm		
DN2	100	4	35	20	BA	
	630	6	35	20	BB	
	630	8	35	21	BC	
	630	6.35	35	20	BD	
DN4	630	6	48	20	BB	
	630	8	47	21	BC	

90° tube stub for tube fitting in conformity with DIN 2353

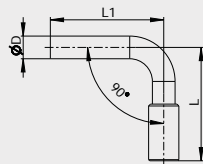

Nominal diameter	Technical specifications					Fitting code
	p ₁ ¹ bar	Ø D mm	L mm	L1 mm		
DN2	630	6	30	28	BG	
DN4	630	6	48	25	BG	

Nipple with male thread

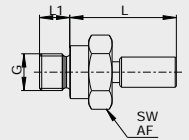

Nominal diameter	Thread	Technical specifications				Fitting code
		p ₁ ¹ bar	AF mm	L mm	L1 mm	
DN2	G	400	14	26.5	8	GA

ORFS fitting

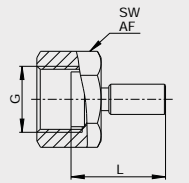

Nominal diameter	Thread	Technical specifications				Fitting code
		p ₁ ¹ bar	AF mm	L mm	L1 mm	
DN2	G	400	22	26.5		HC

¹p₁ = Maximum operating pressure

Fittings for
MINIMESS® hose lines

MINIMESS® pressure gauge and sensor
adapter for bulkheads

Banjo eye fitting with banjo bolt

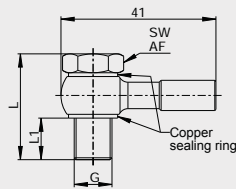

Nominal diameter	Thread G	Technical specifications				Fitting code
		ps ¹ bar	AF mm	L mm	L1 mm	
DN2	M10 x 1	200	14	28	10	IA

Banjo eye fitting as specified in DIN 7642 for M10 x 1 banjo bolt

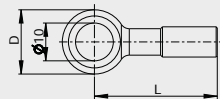

Nominal diameter	Technical specifications			Fitting code
	ps ¹ bar	L mm	L1 mm	
DN2	200	41	17	IB
DN4	200	43.5	17	IB

¹ ps = Maximum operating pressure

The MINIMESS® direct pressure gauge and sensor adapter can be used to connect pressure sensors or gauges with MINIMESS® hose lines to a central system servicing point. This results in significantly easier monitoring and maintenance when used to replace a large number of test points or test points that are difficult to access.

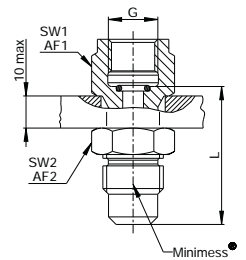

Thread G	Technical specifications				Material: 1.0718 free cutting steel Part No. with NBR seal
	ps ¹ bar	L mm	AF1 mm	AF2 mm	
MINIMESS® 1620					
ISO 228-G 1/4	630	38	19	19	2103-05-11.00N
ISO 228-G 1/2	630	42.5	27	19	2103-05-12.00N
1/4 NPT	630	–	19	19	2103-05-23.00N
MINIMESS® 1615					
ISO 228-G 1/4	630	38	19	19	2102-05-11.00N
ISO 228-G 1/2	630	42.5	27	19	2102-05-12.00N
MINIMESS® 1215					
ISO 228-G 1/4	630	29.5	19	19	2101-05-11.00N
ISO 228-G 1/2	630	42	27	19	2101-05-12.00N
1/4 NPT	630	–	22	24	2101-05-23.00N
MINIMESS® 1604					
ISO 228-G 1/4	630	40.5	22	24	2106-05-11.00N
ISO 228-G 1/2	630	44.5	27	24	2106-05-12.00N
Options					
Part No. with FKM seals					XXXX-XX-XX.10N

¹ ps = Maximum operating pressure

Operating temperature ranges: With NBR seals: -25 °C ... 100 °C / With FKM seals: -20 °C ... 200 °C
Additional versions and materials available upon request.

Original MINIMESS® Minivalv

Maximum Damping. Minimum size.

The MINIMESS® Minivalv is an extremely compact throttle check valve that is typically installed in the hydraulic pilot line so as to restrict the flow at the directional control valve's outlet.

Its purpose is to make sure that poppet motion from or to the neutral position will always be damped so that the corresponding actuator will start up softly and in a controlled manner.

In contrast to a simple restrictor, the way in which this throttle check valve is built ensures that a vacuum cannot be produced at the intake. Moreover, the throttle check valve reduces the volumetric flow rate in one direction of flow and allows it to flow freely in the other. Depending on the desired flow rate, either a hole or a notch is used on the poppet in order to implement the reduced cross section.

Notched poppets are the preferred option for very small reduced cross sections, as they have a special advantage: Impurities that settle inside the notch can be easily flushed out when the direction of flow is reversed. For larger reduced cross sections, poppets with a hole are used instead, as they are more cost-effective.



The MINIMESS® Minivalv throttle check valve

- I Is an effective and cost-effective solution that can be easily integrated and makes it possible to start actuators softly
- I Is ideal for places where space is tight, as it is no bigger than a standard nipple fitting
- I Is available with various orifice sizes and threads
- I Is highly resistant to corrosion (salt spray test longer than 1,000 hours)

Technical specifications	
Operating pressure	– Up to max. 400 bar
Versions	– Restrictor hole diameter of 0.5 mm to 1.0 mm – Restrictor notch, equivalent to a restrictor hole diameter of 0.3 mm to 0.5 mm
Stud end	– 9/16-18 UNF, ISO 11927-2 – ISO 228-G 1/4, ISO 9974-2
Connector end	– 9/16-18 UNF, ISO 8434-3 – 11/16-16 UN, ISO 8434-3 – M14 x 1.5 8L, DIN 2353

Flat Face diagnostic coupling

The Flat Face system has won endless converts as a result of its compact design and the fact that the absence of a thread makes it easy to clean.

The diagnostic coupling is used in applications with hydraulic oils as operating medium, the coupling side conforms to ISO 15171-1, and the maximum operating pressure is 400 bar.

The Flat Face diagnostic coupling is highly resistant to corrosion and successfully passes a 1,000-hour salt spray test.



Test coupling for air brake systems

Coupling for testing initial delay times and pressures in air brake systems for road vehicles in conformity with ISO 3583.



Technical notes

- | Seal types and recommended threaded ports for MINIMESS® test points and gas charging valves
- | Pressure loss curves for MINIMESS® hose and hose lines
- | Installation notes for MINIMESS® hose lines
- | General technical notes for MINIMESS® products
- | Resistance specifications



Seal types and recommended threaded ports for **MINIMESS®** test points and gas charging valves

Hydrotechnik type B
ISO 9974-3, ISO 1179-4



Seal achieved with sealing edge

Hydrotechnik type F
ISO 9974-2, ISO 1179-2



Seal achieved with ED seal

ISO 9974-1, ISO 1179-1

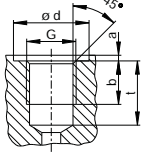

G	d	a	b	t
M10 x 1	15.0	1.0	8.0	13.0
M12 x 1.5	18.0	1.5	12.0	18.5
M14 x 1.5	20.0	1.5	12.0	18.5
M16 x 1.5	22.0	1.5	12.0	18.5
ISO 228-G 1/8	15.0	1.0	8.0	13.0
ISO 228-G 1/4	20.0	1.5	12.0	18.5
ISO 228-G 3/8	23.0	2.0	12.0	18.5
ISO 228-G 1/2	27.0	2.5	14.0	22.0

Hydrotechnik type E
ISO 6149-2, ISO 11926-2, SAE J514



Seal achieved with O-ring

ISO 6149-1, ISO 11926-1, SAE 14026-1

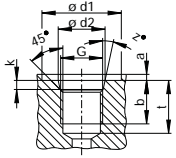

G	d ₁	d ₂	b	k	t	a	z
M10 x 1	19.0	11.1	10.0	1.6	11.5	1.0	12.0
M12 x 1.5	19.0	13.8	11.5	2.4	14.0	1.5	15.0
M14 x 1.5	21.0	15.8	11.5	2.4	14.0	1.5	15.0
M16 x 1.5	24.0	17.8	13.0	2.4	15.5	1.5	15.0
7/16-20 UNF	21.0	12.4	11.5	2.4	14.0	1.6	12.0
1/2-20 UNF	23.0	14.0	11.5	2.4	14.0	1.6	12.0
9/16-18 UNF	25.0	15.6	12.7	2.5	15.5	1.6	12.0
3/4-16 UNF	30.0	20.6	14.3	2.5	17.5	2.4	15.0

Hydrotechnik type C
ISO 3852-2 type C



Seal achieved with suitable sealant

ISO 3852-2 type Z

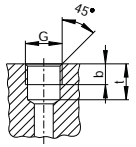

G	b	t
ISO7-1 – R1/8	5.5	9.5
ISO7-1 – R1/4	8.5	13.5

Hydrotechnik type G
HTS 0221



Seal achieved with O-ring

Hydrotechnik in-house standard - HTS 0221

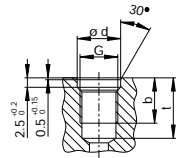

G	d	b	t
M8 x 1	9.5	9.0	13.0
M10 x 1	11.5	9.0	13.0

Seal types and recommended threaded ports for MINIMESS® test points and gas charging valves

Pressure loss curves for MINIMESS® hoses and hose lines

Hydrotechnik type H
ANSI/ASME B1.20.2 type H

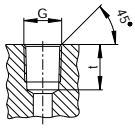

Self-sealing thread

G	t
1/8 NPTF	12.0
1/4 NPTF	17.5

Recommended threaded ports for MINIMESS® p/T test points

Hydrotechnik type F



*) Recommended minimum drilled depth

Hydrotechnik type G

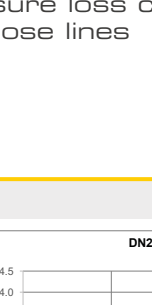

*) Recommended minimum drilled depth

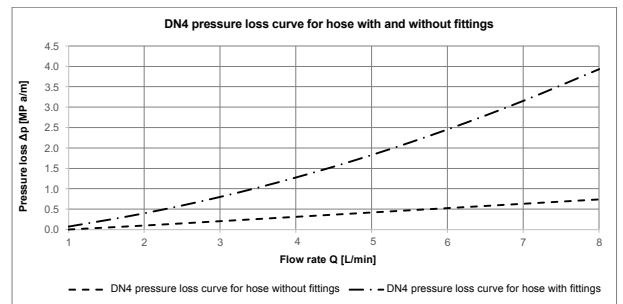
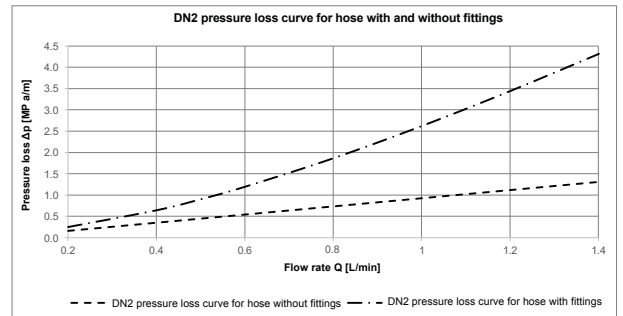

In both diagrams, curve 1 shows the pressure loss of the hose without fittings. Meanwhile, curve 2 shows the pressure loss of the hose line with MINIMESS® fittings on both ends. The oil viscosity is 30 mm²s⁻¹ in both.

Installation notes for MINIMESS® hose lines

General technical notes for MINIMESS® products

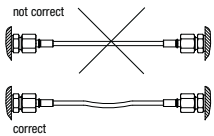
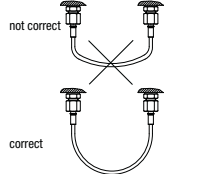
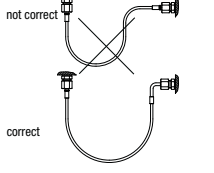
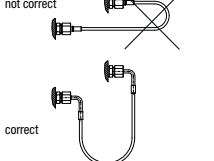
	<p>The length of a hose line can change when the latter is subjected to loads, with a reduction in length entailing a greater tensile load on the hose and the connections. Accordingly, it is important to ensure that the hose line sags a little when depressurized. Please do not tighten the swivel nuts beyond the point where the connection becomes tight, as overtightening them will not improve leak-tightness, but will damage the connection instead.</p>
	<p>If using curved routing, make sure to observe the permissible bend radius and avoid sharp bends. When calculating the length of a hose line that is routed with a curve, keep in mind that the fittings are not flexible. Accordingly, correctly sizing the free hose length between the fittings is essential.</p>
	<p>There are 90° fittings available for when installation situations warrant their use. These fittings have such a small radius that they make it possible to ensure that the corresponding hose will be routed properly even when there is little space available.</p>
	<p>90° fittings should be used when the connections' position does not allow for a "hanging arch" and there is always a risk of kinks close to the connections in the case of a "horizontal arch."</p>

Please make sure to use appropriately sized retainers (e.g., clamps). The hose must not rub against the retainer or be squeezed by it. Moreover, the retainer must preferably go around the hose.

Intended use

MINIMESS® products are intended for use with group 2 fluids as defined in Pressure Equipment Directive 2014/68/EU (non-hazardous fluids).

Chemical compatibility

MINIMESS® test points:

- Are suitable, without restrictions, for HL, HLP, HVL hydraulic fluids in conformity with DIN 51524.
- Are only resistant to fire-resistant and environmentally acceptable hydraulic fluids to a limited extent: HEES, HEPR, HEPG, HFD, HFC in conformity with ISO 12922 and ISO 15380.

Using fire-resistant or environmentally acceptable hydraulic fluids may affect the test points' technical characteristics (temperature range, pressure range, service life, etc.)

MINIMESS® gas charging valves:

- Are suitable, without restrictions, for all inert gases.
- Are also suitable for HL, HLP, HVL hydraulic fluids in conformity with DIN 51524.

MINIMESS® hose lines:

- Are suitable, without restrictions, for HL, HLP, HVL hydraulic fluids in conformity with DIN 51524.

For information regarding compatibility with other fluids, please refer to the resistance specifications on page 69. The use of other fluids must be checked on a case-by-case basis.

Certification criteria

MINIMESS® products are tested and certified in conformity with the relevant standards. Moreover, when there are no standards for specific characteristics, we define our own test criteria for those characteristics based on standards for related products, ensuring that we can stand 100 percent behind our products.

Testing is carried out on build samples for the corresponding item or on parts that are identical in terms of the characteristics being tested.

Resistance to corrosion

MINIMESS® products made of free cutting steel are protected against corrosion with a zinc-nickel coating. A corrosion resistance > 1,000 h has been verified with a salt spray test in conformity with DIN EN ISO 9227.

Pressure Equipment Directive 2014/68/EU

MINIMESS® test points, gas charging valves, and hose lines are designed and manufactured in conformity with the sound engineering practice of Germany as required by Article 4 of the Pressure Equipment Directive 2014/68/EU. This guarantees the safety of our products. These products should not bear the CE marking.

Packaging

Packing unit in cardboard box or in polyethylene bag and outer packaging. Alternatives available upon request.

Storage recommendations

MINIMESS® products with elastomeric seals:

Shelf lives vary by elastomer type in conformity with DIN 7716.

The storage period until installation and commissioning should not exceed 2 years.

MINIMESS® hose lines:

Storage and transportation instructions in conformity with DIN EN ISO 8331

- Store in a cool and dry place. Avoid direct exposure to sunlight and UV rays.
- Avoid sources of radiant heat.
- Avoid ozone-generating lamps and electrical equipment that produces sparks in the immediate vicinity.
- The ideal storage conditions are temperatures between +15 °C and +25 °C, a relative humidity of 65%, and UV-blocking film in order to shield from UV radiation.

A storage time of 2 years should not be exceeded for hoses.

REACH Regulation (EU) No.1907/2006, Art. 33

As a manufacturer of products, HYDROTECHNIK GmbH is a downstream user of low quantities and accordingly is not subject to mandatory registration.

In accordance with Article 33 of the REACH Regulation, we are hereby informing you that the free machining steel products we supply may contain a lead concentration of up to 0.35% weight by weight and that the brass products we supply may contain a lead concentration of up to 3.5% weight by weight.

Other than this, our products do not contain any other substances found in the 2019 Candidate List of Substances of Very High Concern (SVHC).

Safety notes

Products must be assembled and installed exclusively by qualified personnel. It is recommended to always keep the protective cap on MINIMESS® test points and gas charging valves in place when they are not being used directly as system access points.

General notes

The products must be used exclusively as intended. The purchaser is responsible for making sure that the products are suitable for the intended application and for use under the corresponding operating conditions, and Hydrotechnik GmbH hereby disclaims all liability within this context.

We reserve the right to make changes to products and documentation, as a result of technological progress and continuous improvement, without notice. The specifications applicable after these changes may be different from the specifications in this catalog.

Resistance specifications

- | Seal materials: NBR (Perbunan), FKM (Viton)
- | 1.0718 free cutting steel (11SMnPb30+C), zinc-nickel-electroplated surface
- | 1.4104 stainless steel (X12CrMoS17)
- | 1.4571 stainless steel (X6CrNiMoTi17-12-2)
- | Hoses: Polyamide



Fluid	Seal materials		Fitting material			Hoses			
	NBR	FKM	1.0718	1.4104	1.4571	20 °C	40 °C	60 °C	90 °C
Acetone	3	3	1	2	1	1/5	1/6	2	3
Ethanol, pure	1	1-2	1	1	1	1/6	2	3	
Ammonia, concentrated		3 *)	1	1	1	1	1	1	1
Ammonia, liquid	2	3 *)	1	1	1	1	1		
Formic acid	3	3 *)	3	2	1	3	3	3	
Gasoline, pure	1	1	1	1	1	1	1	1/6	
Benzene	3	1-2	1	1	1	1	1/6	2	2
Brake fluid	3	3 *)	1	1	1	1	1	1	2
Butane	1	1	2	1	1	1	1	1	1
Cyclohexane	1	1	1	1	1	1	1	1	2
Diesel fuel	1	1	1	1	1	1	1	1	1
Freon, R12	2	1-2	1	1	1	1	1	1	1
Glycerol, pure	2	1-2	1	1	1	1	1	1	1
Glycol	1	1-2	1	1	1	1	1	2	3
Heating oil	1	1	1	1	1	1	1	1	1
Hydraulic fluid (mineral-based)	1	1	1	1	1	1	1	1	1
Kerosene	2	1	1	1	1	1	1	1/6	
Carbonic acid	1	1	3	1	1	1/4	1/4	1/4	
Methane	1	1	2	1	1	1/4	1/4	1/4	
Methyl alcohol, pure	1	3 *)	1	1	1	1/6	2	3	
Mineral oils	1	1	1	1	1	1	1	1	1
Petroleum	1	1	1	1	1	1	1	1/6	
Polyalkylene glycols (HEPG)		2 (<100 °C)	2	1	1	1	1	2/4	3/4
Propane	1	1	2	1	1	1/4	1/4	1/4	
Oxygen	2	1	3	1	1	1/4	1/4	2/4	3/4
Lubricating oils and greases	1	1	1	1	1	1	1	1	1
Soap suds	1	1	3	1	1	1	1	1	1
Nitrogen	1	1	1	1	1	1/4	1/4	1/4	
Synthetic esters (HEES)		2 (<100 °C)	1	1	1	1	1	2/4	3/4
Turpentine	2	1	2	1	1	1	1	1/6	
Carbon tetrachloride	3	1	2	1	1	1	3		
Toluene	3	1-2	2	1	1	1	1/6	2	2
Trichloroethylene	3	1-2	1	1	1	2	3		
Triglycerides (vegetable oil) HETG	1	2 (<80 °C)	1	1	1	1	1	2/4	3/4
Water	1	1	3	1	1	1	1	1	1
Seawater	1	1	3	3	2	1	1	1	1

Key:

- 1 = Good; absolute resistance without any changes
- 2 = Limited; resistance depends on length of use and operating conditions
- 3 = Not recommended; the material will be attacked and the mechanical properties will degrade
- 4 = Light diffusion in the cases of gases; use only as a testing and filling hose. For continuous use, we recommend our stainless steel pipes instead
- 5 = Slight transparent material discoloration
- 6 = Light swelling but no changes to mechanical properties

*) Suitable seal materials available upon request

Hydrotechnik Sensors





















HySense®

HySense® family

The Greek philosopher Heraclitus said it over 2,500 years ago: "Panta rhei." This saying, which can be translated as "everything flows," still holds true today, when success in the cutting-edge plant and production worlds of Industry 4.0 depends significantly on data quality and system precision. Needless to say, this also means that the success of an industrial measurement depends on the reliability of the corresponding data acquisition. That is where Hydrotechnik sensors come in with their extraordinary quality and reliability.

Technicians, engineers, and skilled workers who commission, operate, maintain, and repair systems and machines need valid data from sound measurements. In fact, this is the only way for them to be able to take the right actions and meet their customers' expectations. And R&D specialists, such as development and applications engineers in the plant and machine design engineering fields, also benefit from the know-how that goes into our products, which is

why they and the aforementioned professionals all appreciate our "Made by Hydrotechnik" high-precision sensors. These sensors are optimized for use in high-pressure fluid systems and hydraulic systems in particular, but they are also in use in many other areas. And this should come as no surprise, as the products combine a robustness and long life that meet all the requirements involved in continuous use with a solid price–performance ratio. Moreover, our in-house DAkkS-accredited calibration laboratory guarantees maximum accuracy and consistent quality for every single one of our sensors.

<p>FLOW RATE QT – Turbine flow meters QG – Gear flow meters QL – Turbine flow meters with integrated throttle valve QO – Oval gear flow meters</p>	<p>QT series – Pages 80 – 93</p> 	<p>QG series – Pages 94 – 99</p> 	<p>QL series – Pages 100 – 105</p> 	<p>QO series – Pages 106 – 107</p> 				
<p>PRESSURE PR – Pressure sensors PS / MultiEPC – Pressure switches</p>	<p>PR 1xx – Pages 112 – 121</p> 	<p>PR 126 – Page 116</p> 	<p>PR 400 – Pages 122 – 123</p> 	<p>PR 509 – Pages 124 – 125</p> 	<p>MultiEPC Pages 126 – 127</p> 	<p>PS 280 – Pages 128 – 129</p> 	<p>Analog pressure gauges Pages 130 – 132</p> 	<p>Digital pressure gauges Pages 133 – 134</p> 
<p>TEMPERATURE TE – Temperature sensors TP – Temperature and pressure sensors</p>	<p>TE 200 – Page 138</p> 	<p>TE 3xx – Pages 140 – 142</p> 	<p>TE 400 – Page 143</p> 	<p>TP 180 – Pages 144 – 145</p> 				
<p>OIL CONDITION CL – Level sensors CM – Moisture sensors CV – Viscosity sensors CX – Service measuring kit CW – Wear sensors</p>	<p>CL 1xx – Pages 148 – 149</p> 	<p>CM 100 – Pages 150 – 151</p> 	<p>CV 100 – Pages 152 – 153</p> 	<p>CX 197 – Pages 154 – 155</p> 	<p>CW 100 – Pages 156 – 157</p> 			
<p>FORCE AND TORQUE FO – Force sensors TQ – Torque sensors</p>	<p>FO 200 – Pages 158 – 159</p> 	<p>FO 300 – Pages 160 – 161</p> 	<p>TQ 100 – Pages 162 – 163</p> 					
<p>SPEED, POSITION, VIBRATION, TRANSDUCERS RS – Speed sensors PO – Position sensors VB – Vibration sensors SC – Signal converter</p>	<p>RS 100 – Pages 164 – 165</p> 	<p>RS 3xx – Page 166</p> 	<p>RS 5xx – Pages 167 – 168</p> 	<p>PO 180 – Pages 169 – 170</p> 	<p>VB 110 – Pages 171 – 172</p> 	<p>SC 100 – Page 173</p> 		



HySense® Q Flow meters

Hydrotechnik HySense® Sensor intelligence

ISDS (Intelligent Sensor Detection System) functionality

The ISDS functionality developed by Hydrotechnik makes it much easier to operate Hydrotechnik measuring equipment while also improving measurement accuracy. This functionality consists of two main functions:

Automatic sensor detection in the Hydrotechnik measuring device

After a sensor is connected to the measuring device, the corresponding channels (sensor signal, measurement variable, measuring range, etc.) are configured in the measuring device automatically. This means that users do not need to configure the sensors in the device, effectively making the sensors plug-and-play devices, preventing input mistakes, and making life easier for users in general.

Reading linearization in the measuring device

In order to improve performance, the sensor characteristic curve determined during calibration is stored in a table in the sensor. Then, as soon as the sensor is connected to the measuring device, the device reads the table and starts using it to linearize the sensor readings. The result? Significantly higher measuring accuracy.

Smart sensors

The term "smart sensors" refers to sensors that, in contrast to conventional ones, not only measure properties, but also take care of processing the corresponding signal completely and process and interpret their readings based on stored algorithms. These sensors contain a microcontroller with sufficient computing power, and are accordingly also referred to as "intelligent sensors." All our smart sensors come with our ISDS functionality, but the difference is that the linearization is carried out in the sensor itself rather than externally by the measuring device. The Hydrotechnik portfolio features a large number of smart sensors, such as the **HySense®** QT 510, RS 510, CX 197, SC 100, etc.

HySense® Q family

The flow meters in the **HySense® Q** family are the result of decades of experience developing and manufacturing flow meters. Combined with the tools of the trade, such as our in-house DAKkS calibration laboratory, our production operations, etc., this experience enables Hydrotechnik to consistently deliver extraordinarily reliable quality and cost-effectiveness.

Both the global move towards renewables and the accompanying concern with energy efficiency have made flow metering absolutely crucial, as it is an indispensable part of development activities, diagnostic work, condition monitoring, and predictive maintenance for fluid systems. And as a solution provider in the field, Hydrotechnik has four different product families that cover virtually every application thanks to their versatility and that have specific advantages and characteristics each.

HySense® QT

Turbine flow meters: **HySense® QT**

Characteristics

- | High measuring accuracy and reproducibility
- | Flow measurements with a high dynamic range
- | Compact and lightweight
- | Heavy-duty construction for high operating pressures and resistance up to 420 bar
- | Low pressure losses

Applications

- | Stationary and mobile flow measurements
- | Testing pump units
- | Adjusting the flow rate for hydraulic attachments on heavy equipment
- | Heating and cooling circuit condition monitoring
- | Lubricant monitoring in manufacturing systems
- | Systems with dynamic and bidirectional flow rates
- | Diagnostic tasks



HySense® QG

Gear flow meters: **HySense® QG**

Characteristics

- | Wide measuring range combined with extremely high measuring accuracy and reproducibility
- | Wide viscosity range; performance virtually unaffected by different viscosities
- | Heavy-duty construction for high operating pressures and resistance up to 630 bar
- | Integrated flow direction detection

Applications

- | Volume and flow rate measurements
- | Cylinder travel or speed measurements
- | Filling and metering an extremely wide variety of fluids
- | Ensuring correct mixing ratios
- | Leakage measurement and rupture monitoring
- | Measuring tasks for control purposes in test stands
- | Fuel consumption measurements



HySense® QL

Turbine flow meters with integrated throttle valve: **HySense® QL**

Characteristics

- | Integrated proportional valve for load simulations
- | High measuring accuracy and reproducibility
- | Flow measurements with a high dynamic range
- | Body made of high-strength aluminum; lightweight
- | Heavy-duty construction for high operating pressures and resistance up to 420 bar

Applications

- | Stationary and mobile flow measurements
- | Testing the operation and performance of pump units
- | Adjusting pump controllers and pressure control valves
- | Diagnostic tasks



HySense® QO

Oval gear flow meters: **HySense® QO**





Characteristics

- | High measuring accuracy and reproducibility
- | No straight pipe runs required for the inlet and outlet
- | Wide viscosity range
- | Can be disassembled for cleaning
- | High resistance to aggressive fluids
- | High temperature resistance

Applications

- | Volume and flow rate measurements
- | Filling and metering
- | Fuel consumption measurements
- | Measuring tasks for control purposes in test stands
- | Measurements in aggressive fluids



Series	Measuring range L/min	Output signal / Measuring accuracy	Mechanical connection	Fluid	Special characteristics
QT 2xx Pages 82 – 83 Product discontinued	 1 ... 10 5 ... 100 15 ... 300 25 ... 600	Frequency (Hz) ±0.5% of reading ^{1,2} CANopen ±0.5% of reading ² Analog 4 ... 20 mA ±0.5% of reading ² plus ±0.1% of full scale	ISO 228 G 1/4, G 3/4, G 1 1/4, G 1 1/2	Water, oil-in-water emulsion, water and glycol mixtures, liquids containing water such as HFA / HFC	Stainless steel body for harsh ambient conditions A wide variety of sizes Carbide plain bearing
QT 3xx Pages 84 – 85	 45 ... 1000	Frequency (Hz) ±0.5% of reading ^{1,2} CANopen ±0.5% of reading ² Analog 4 ... 20 mA ±0.5% of reading ² plus ±0.1% of full scale	SAE 2" code 62	Fuels, water, hydraulic fluids, transmission fluids, oil-in-water emulsions, water and glycol mixtures, brake fluid, Skydrol	Low pressure differential Flow rate measurements up to 1000 L/min SAE flange connection Stainless steel body
QT 4xx Pages 86 – 87	 16 ... 600	Frequency (Hz) ±0.5% of reading ^{1,2} CANopen ±0.5% of reading ² Analog 4 ... 20 mA ±0.5% of reading ² plus ±0.1% of full scale	ISO 228 G 1 1/4	Fuels, hydraulic fluids, transmission fluids, brake fluid, Skydrol	Reinforced construction for especially harsh operating conditions
QT 5xx Pages 88 – 90	 1 ... 20 2 ... 75 5 ... 150 9 ... 300 16 ... 600	Frequency (Hz) ±0.5% of reading ^{1,2} CANopen ±0.5% of reading ² Analog 4 ... 20 mA ±0.5% of reading ² plus ±0.1% of full scale	ISO 228 G 1/4, G 3/4, G 1, G 1 1/4 ANSI B1.1 7/16-20 UN, 1 1/16-12 UN, 1 5/16-12 UN, 1 5/8-12 UN	Fuels, water, hydraulic fluids, transmission fluids, oil-in-water emulsions, water and glycol mixtures, brake fluid, Skydrol	Hydraulotechnik standard A wide variety of sizes Stainless steel and aluminum body
QT 600 Pages 91 – 93	 9 ... 300	Frequency (Hz) / ±2.5% of reading for 5 ... 100 mm ² /s	ISO 228 G 1	Hydraulic fluids, transmission fluids, and other mineral-based oils	Flow measurements for a wide viscosity range with extremely high measuring accuracy Integrated temperature measurement Aluminum body

¹ Different if a constant calibration value is used; please refer to the technical data sheet
² With calibration viscosity

HySense® QT 2xx

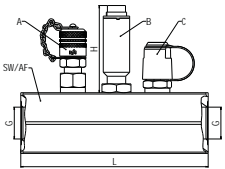

Product
discontinued

A	MINIMESS® 1620 series p/T test point
B	HySense® RS series inductive sensor
C	MINIMESS® 1620 series test point

Flow rate	Measuring range L/min	G ISO 228	AF mm	L mm	Weight g	H		
						QT 200	QT 206	QT 210
10 L/min	1 ... 10	G 1/4	27	120	Approx. 795			
100 L/min	5 ... 100	G 3/4	46	142	Approx. 2040			
300 L/min	15 ... 300	G 1 1/4	60	181	Approx. 3400	62 mm		98 mm
600 L/min	25 ... 600	G 1 1/2	65	185	Approx. 4100			

Flow rate	Max. operating pressure bar	Measuring accuracy		
		QT 200 ¹	QT 206	QT 210 ²
10 L/min	420	±0.5% of reading		
100 L/min				
300 L/min				
600 L/min		350		

¹ Different if a constant calibration value is used; please refer to the technical data sheet
² Additionally ±0.1% of full scale

Part No. 33 X C - Y Y - 35 . V 0 1 2 G PRODUCT DISCONTINUED

Sensor	Thread / Flow range
X = C QT 206 CANopen, M12 electrical connector, 5-pin, ISDS	YY = 01 ISO 228-G 1/4 1 ... 10 L/min
I QT 210 analog 4 ... 20 mA, M12 electrical connector, 4-pin, ISDS	77 ISO 228-G3/4 5 ... 100 L/min
J QT 210 analog 4 ... 20 mA, M16 electrical connector, 6-pin, ISDS	78 ISO 228-G 1 1/4 15 ... 300 L/min
K QT 200 frequency, M12 electrical connector, 4-pin, ISDS	79 ISO 228-G1 1/2 25 ... 600 L/min
V QT 200 frequency, M16 electrical connector, 6-pin, ISDS	

General characteristics

Fluid	Water, oil-in-water emulsion, water and glycol mixtures, and liquids containing water such as HFA / HFC*
Flow range	1 ... 600 L/min*
Output signal	Frequency, CANopen, 4 ... 20 mA
Response time	< 0.05 s
Viscosity range	1 ... 10 mm ² /s (cSt)* Calibration viscosity: 2.5 mm ² /s*
Measuring accuracy	Up ... ±0.5% of reading
Fluid temperature	-20 °C ... 100 °C*
Ambient temperature	-20 ... 85 °C
Turbine housing material	Stainless steel
Seal material	FKM*
IP degree of protection	IP67 (DIN EN 60529)

* More available upon request

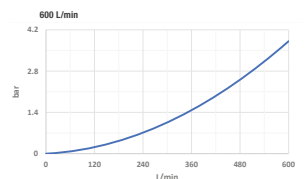
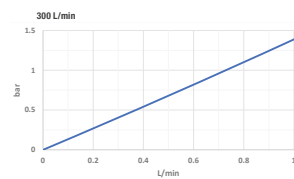
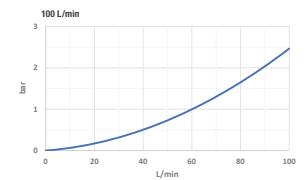
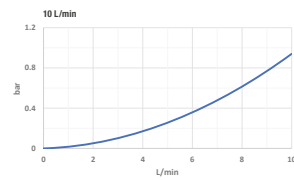
Pressure differential at 2.5 mm²/s*

HySense® QT 3xx

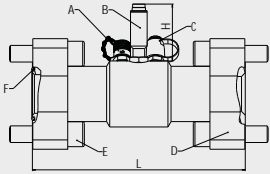
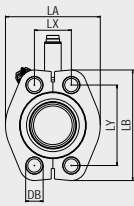

A	MINIMESS® 1620 series p/T test point
B	HySense® RS series inductive sensor
C	MINIMESS® 1620 series test point
D	SAE flange halves
E	Socket cap screws
F	SAE seal (O-ring) ID 56.74 x 3.53 90 Shore A, NBR

General characteristics

Fluid	Fuels, water, hydraulic fluids, transmission fluids, oil-in-water emulsions, water and glycol mixtures, brake fluid, Skydrol*
Flow range	45 ... 1000 L/min*
Output signal	Frequency, CANopen, 4 ... 20 mA
Response time	< 0.05 s
Viscosity range	1 ... 150 mm ² /s (cSt)*
Measuring accuracy	Up to ±0.5% of reading
Fluid temperature	-20 °C ... 100 °C*
Ambient temperature	-20 ... 85 °C
Turbine housing material	Stainless steel
Seal material	FKM*
IP degree of protection	IP67 (DIN EN 60529)

* More available upon request

Flow rate	Measuring range	Connection	L	LA	LB	Weight	H		
	L/min	SAE J518	mm	mm	mm	without flange	QT 300	QT 306	QT 310
1000 L/min	45 ... 1000	2" flange	256	113.8	133	Approx. 5400 g	62 mm	98 mm	

Flow rate	Max. operating pressure	Measuring accuracy
	bar	QT 300 ¹ QT 306 QT 310 ²
1000 L/min	420	±0.5% of reading

¹ Different if a constant calibration value is used; please refer to the technical data sheet² Additionally ±0.1% of full scale

Part No. 3WXF-88-35.ZZZZ

Chemical compatibility

W = 1	Hydraulic fluids, transmission fluids
W = 3	Water, oil-in-water emulsion, water and glycol mixtures, liquids containing water such as HFA / HFC (available starting mid-2020)
W = A	Skydrol (available starting mid-2020)

Sensor

X = C	QT 306 CANopen, M12 electrical connector, 5-pin, ISDS
X = I	QT 310 analog 4 ... 20 mA, M12 electrical connector, 4-pin, ISDS
X = J	QT 310 analog 4 ... 20 mA, M16 electrical connector, 6-pin, ISDS
X = K	QT 300 frequency, M12 electrical connector, 4-pin, ISDS
X = V	QT 300 frequency, M16 electrical connector, 6-pin, ISDS

Calibration viscosity

W = 1	→ 30 mm ² /s: ZZZZ = 030
W = 3	→ 2.5 mm ² /s: ZZZZ = V012
W = A	→ 11 mm ² /s: ZZZZ = 011

Included:

Four 2" SAE flange halves, straight
One SAE seal
Eight DIN 912 socket cap screws

Additional
flow ranges of up to
1500 L/min available
upon request

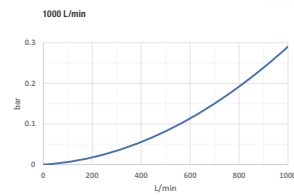
Pressure differential at 30 mm²/s

HySense® QT 4xx

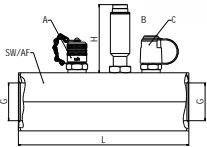

A	MINIMES® 1620 series p/T test point
B	HySense® RS series inductive sensor
C	MINIMES® 1620 series test point

General characteristics

Fluid	Fuels, hydraulic fluids, transmission fluids, brake fluid, Skydrol*
Flow range	16 ... 600 L/min*
Output signal	Frequency, CANopen, 4 ... 20 mA
Response time	< 0.05 s
Viscosity range	1 ... 150 mm ² /s (cSt)*
Measuring accuracy	Up to ±0.5% of reading
Fluid temperature	-20 °C ... 100 °C*
Ambient temperature	-20 ... 85 °C
Turbine housing material	Stainless steel
Seal material	FKM*
IP degree of protection	IP67 (DIN EN 60529)

* More available upon request

Flow rate	Measuring range	G	AF	L	Weight	H		
	L/min	ISO 228	mm	mm	g	QT 400	QT 406	QT 410
600 L/min	16 ... 600	G 1 1/4	60	176	Approx. 3600	62 mm	98 mm	

Flow rate	Max. operating pressure	Measuring accuracy
	bar	QT 400 ¹ QT 406 QT 410 ²
600 L/min	420	±0.5% of reading

¹ Different if a constant calibration value is used; please refer to the technical data sheet² Additionally ±0.1% of full scale

Part No. 3WYG-72-35.ZZZ

Chemical compatibility

W = R Hydraulic fluids, transmission fluids

A Skydrol[®] (available starting mid-2020)

Sensor

Y = C QT 406 CANopen, M12 electrical connector, 5-pin, ISDS
 I QT 410 analog 4 ... 20 mA, M12 electrical connector, 4-pin, ISDS
 J QT 410 analog 4 ... 20 mA, M16 electrical connector, 6-pin, ISDS
 K QT 400 frequency, M12 electrical connector, 4-pin, ISDS
 V QT 400 frequency, M16 electrical connector, 6-pin, ISDS

Calibration viscosity

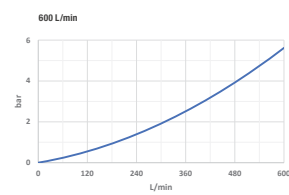
W = R → 30 mm²/s: ZZZ = 030W = A → 11 mm²/s: ZZZ = 011Pressure differential at 30 mm²/s

HySense® QT 5xx

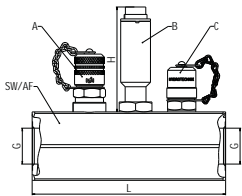

A	MINIMES® 1620 series p/T test point
B	HySense® RS series inductive sensor
C	MINIMES® 1620 series test point

Flow rate	Measuring range L/min	G ISO 228	AF mm	L mm	Weight g	H		
						QT 500	QT 506	QT 510
20 L/min	1 ... 20	G 1/4	41	100	Approx. 685			
75 L/min	2 ... 75	G 3/4	46	130	Approx. 900			
150 L/min	5 ... 150	G 3/4	55	140	Approx. 1150	62 mm		98 mm
300 L/min	9 ... 300	G 1	55	150	Approx. 1230			
600 L/min	16 ... 600	G 1 1/4	60	174	Approx. 1520			

Flow rate	Max. operating pressure bar	Measuring accuracy		
		QT 500 ¹	QT 506	QT 510 ²
20 L/min	420	±0.5% of reading		
75 L/min				
150 L/min				
300 L/min				
600 L/min	350			

¹ Different if a constant calibration value is used; please refer to the technical data sheet

² Additionally ±0.1% of full scale

Part No. 3WXH-YY-35.ZZZZ

Chemical compatibility

W = 1	Hydraulic fluids, transmission fluids
3	Water, oil-in-water emulsion, water and glycol mixtures, liquids containing water such as HFA / HFC (available starting mid-2020)
A	Skydrol® (available starting mid-2020)

Sensor

X = C	QT 506 CANopen, M12 electrical connector, 5-pin, ISDS
I	QT 510 analog 4 ... 20 mA, M12 electrical connector, 4-pin, ISDS
J	QT 510 analog 4 ... 20 mA, M16 electrical connector, 6-pin, ISDS
K	QT 500 frequency, M12 electrical connector, 4-pin, ISDS
V	QT 500 frequency, M16 electrical connector, 6-pin, ISDS

Thread / Flow range

YY = 02	ISO 228-G 1/4	1 ... 20 L/min
70	ISO 228-G 3/4	2 ... 75 L/min
71	ISO 228-G 1	9 ... 300 L/min
72	ISO 228-G 1 1/4	16 ... 600 L/min
73	ISO 228-G 3/4	5 ... 150 L/min
12	7/16-20 UN	0.26 ... 5.3 GPM
80	1 1/16-12 UN	0.6 ... 20 GPM
81	1 5/16-12 UN	2.4 ... 80 GPM
82	1 5/8-12 UN	4.2 ... 160 GPM
83	1 5/16-12 UN	1.3 ... 40 GPM

Calibration viscosity

W = 1	→ 30 mm ² /s: ZZZZ = 030
W = 3	→ 2,5 mm ² /s: ZZZZ = V012
W = A	→ 11 mm ² /s: ZZZZ = 011

General characteristics

Fluid	Fuels, water, hydraulic fluids, transmission fluids, oil-in-water emulsions, water and glycol mixtures, brake fluid, Skydrol®
Flow range	1 ... 600 L/min*
Output signal	Frequency, CANopen, 4 ... 20 mA
Response time	< 0.05 s
Viscosity range	1 ... 150 mm ² /s (cSt)*
Measuring accuracy	Up to ±0.5% of reading
Fluid temperature	-20 °C ... 100 °C*
Ambient temperature	-20 ... 85 °C
Turbine housing material	Stainless steel / aluminum
Seal material	FKM*
IP degree of protection	IP67 (DIN EN 60529)

* More available upon request

Pressure differential at 30 mm²/s

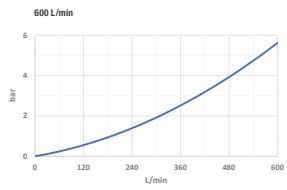
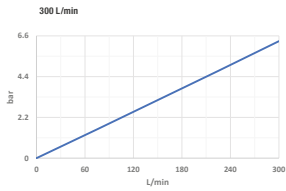
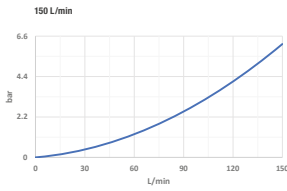
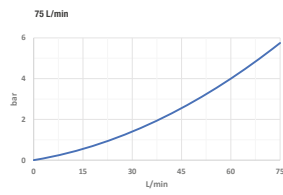
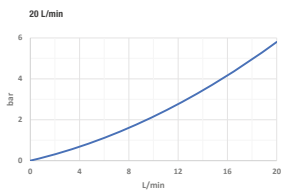

HySense® QT 600

In combination with the measuring devices in the MultiSystem series, the new Hydrotechnik **HySense® QT 600** turbine meter generation makes it possible to measure volumetric flow rates accurately with various hydraulic fluids and varying temperatures.

The technology not only combines high flexibility with user friendliness and ease of use, but also saves users a significant amount of time.

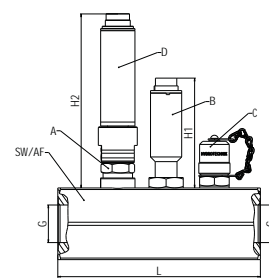

A	MINIMESS® 1620 series p/T test point
B	HySense® RS series inductive sensor
C	MINIMESS® 1620 series test point
D	HySense® TE series temperature sensor

General characteristics

Fluid	Hydraulic fluids, transmission fluids
Flow range	9 ... 300 L/min*
Output signal	Frequency
Response time	< 0.05 s
Viscosity range	5 ... 100 mm ² /s (cSt)*
Fluid temperature	-20 °C ... 100 °C*
Ambient temperature	-20 ... 85 °C
Turbine housing material	Aluminum
Seal material	FKM*
IP degree of protection	IP67 (DIN EN 60529)

* More available upon request

Flow rate	Measuring range	G	AF	L	Weight	H1	H2
L/min	L/min	ISO 228	mm	mm	g	mm	mm
300 L/min	9 ... 300	G 1	55	150	Approx. 1230	62 mm	98 mm

Flow rate	Max. operating pressure	Measuring accuracy
L/min	bar	QT 600
300 L/min	420	±2.5% of reading

Part No. 31VU-71-35.V036

Characteristic curve for standard turbine meters, calibrated at 30 mm²/s, used with varying viscosity

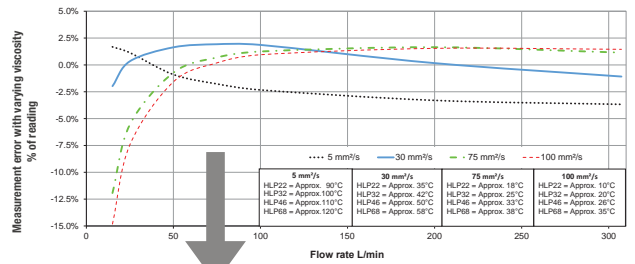

Characteristic curve for the HySense® QT 600, used with varying viscosity

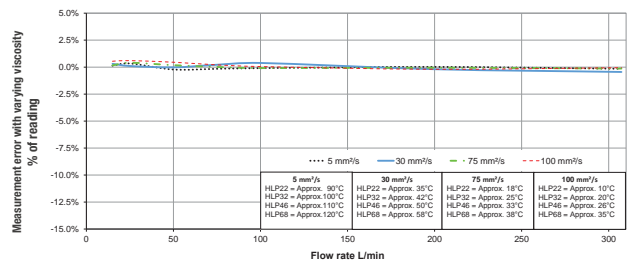

Pressure differential at 30 mm²/s

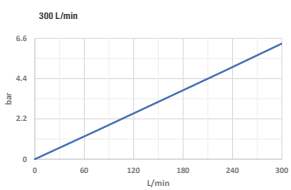

HySense® QG 100

The gear flow meters in the **HySense® QG** family are the result of decades of experience developing and manufacturing flow meters. Gear flow meters are positive displacement meters and use one of the most accurate methods available for measuring flow.

HySense® QG 100 is part of the standard series in the Hydrotechnik portfolio. As a result of its tooth geometry, the various bearing solutions, and premium-grade materials, the **HySense® QG 100** is a true all-rounder when it comes to volume and flow measurement.

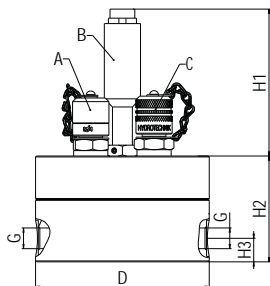

A	MINIMESS® 1620 series test point
B	HySense® RS series inductive sensor
C	MINIMESS® 1620 series p/T test point



General characteristics

Fluid	Fuels, hydraulic fluids, transmission fluids, brake fluid, Skydrol*
Flow range	0.005 ... 300 L/min*
Output signal	Frequency / 4 ... 20 mA**
Viscosity range	1 ... 120,000 mm ² /s (cSt)*
Measuring accuracy	Up to ±0.4% of reading
Fluid temperature	-20 °C ... 100 °C***
Ambient temperature	-20 °C ... 85 °C***
Top material	Stainless steel*
Center / base material	GJS*
Seal material	FKM / EPDM*
Electrical measuring connector	5-pin / 6-pin M16 x 0.75" circular connector
IP degree of protection	IP67 (DIN EN 60529)

* More available upon request

** For 4 ... 20 mA, HySense® SC 100 required (please refer to page 173)

*** High-temperature version for up to 160 °C available upon request

Flow rate	Measuring range	G	D	Weight	H1	H2	H3
	L/min		mm	g			
1 L/min	0.005 ... 1	ISO 228-G 1/4	84	Approx. 1600	67	50	12
5 L/min	0.05 ... 5	ISO 228-G 1/4	96	Approx. 2700	66	59	13
30 L/min	0.2 ... 30	ISO 228-G 3/8	106	Approx. 3600	66	67	15
70 L/min	0.7 ... 70	ISO 228-G 3/4	136	Approx. 8500	60	93	20
300 L/min	3.0 ... 300	SAE 1-1/4	210	Approx. 32000	45	145	42

Flow rate	Max. operating pressure	Measuring accuracy
	bar	
1 L/min	420	±0.5% of reading
5 L/min	420	±0.5% of reading
30 L/min	420	±0.5% of reading
70 L/min	420	±0.4% of reading
300 L/min	420	±0.5% of reading

Part No. **3W43-XX-Y-35.ZZZ**

Chemical compatibility

W = 1 Hydraulic fluids, transmission fluids

A Skydrol (available starting mid-2020)

Thread / Flow range

XX = 01 ISO 228-G 1/4 0.005 ... 1 L/min

02 ISO 228-G 1/4 0.05 ... 5 L/min

03 ISO 228-G 3/8 0.2 ... 30 L/min

04 ISO 228-G 3/4 0.7 ... 70 L/min

05 1 1/4 SAE flange 3 ... 300 L/min

Electrical connector

Y = S 6-pin M16 x 0.75 circular connector, ISDS

5-pin M16 x 0.75 circular connector, not compatible with HySense® SC 100 (Omit "Y" from the Part No. when choosing this version)

Calibration viscosity

W = 1 → 30 mm²/s **ZZZ = 030**

W = A → 11 mm²/s **ZZZ = 011**

HySense® QG 200

HySense® QG 200 is our high-end solution in the area of gear flow meters. The series as a whole makes an undeniably compelling case with its high measuring accuracy, heavy-duty durability, an extremely wide measuring range, and flow direction detection. Moreover, the option to use manifold mounting or threaded connections on the side allows for flexible system integration.

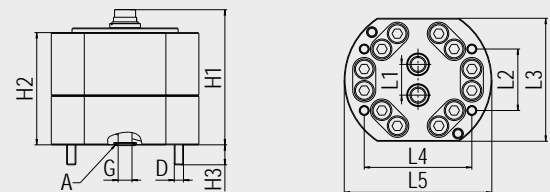
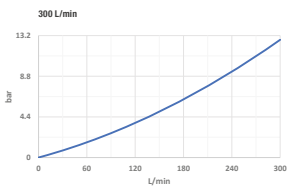
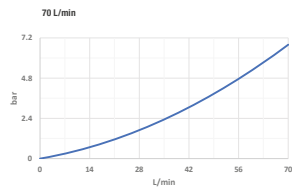
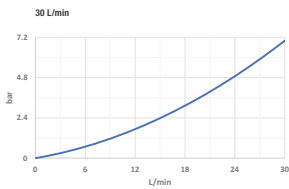
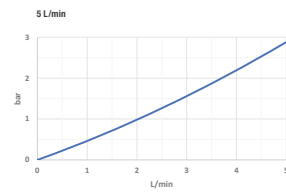
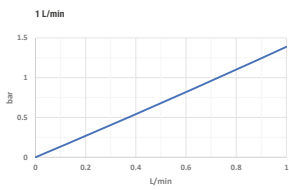

Threaded connections on the side available upon request

Pressure differential at 30 mm²/s

General characteristics

Fluid	Fuels, hydraulic fluids, transmission fluids, brake fluid, Skydrol*
Flow range	0.005 ... 120 L/min*
Output signal	Frequency / 4 ... 20 mA**
Viscosity range	1 ... 120,000 mm ² /s (cSt)*
Measuring accuracy	Up to ±0.3% of reading
Fluid temperature	-20 ... 100 °C
Ambient temperature	-20 ... 85 °C
Top material	Stainless steel*
Center / base material	Stainless steel*
Seal material	FKM / EPDM*
Electrical measuring connector	6-pin M16 x 0.75" circular connector
IP degree of protection	IP67 (DIN EN 60529)
Mechanical connection	Manifold mounting / threaded connection on the side

* More available upon request

** For 4 ... 20 mA, HySense® SC 100 required

Flow rate	Measuring range	Max. Operating pressure	D	H1	H3	L1	L2	L3	L4	L5	Weight
	L/min	bar	DIN 13-1	mm	mm	mm	mm	mm	mm	mm	g
2 L/min	0.005 ... 2	450	M6	89	15	20	40	80	70	96	Approx. 3180
10 L/min	0.01 ... 10		M6	89	15	20	40	80	70	96	Approx. 3180
40 L/min	0.03 ... 40		M8	90	24	34	38	90	80	110	Approx. 4235
120 L/min	0.2 ... 120		M8	119	22	34	72	100	84	142	Approx. 9223

Part No. 3WUX-YY-PV.ZZZ

Chemical compatibility

W = 1 Hydraulic fluids, transmission fluids

A Skydrol (available starting mid-2020)

Measuring accuracy

X = 0 Measuring accuracy: ±0.5% of reading

A Measuring accuracy: ±0.3% of reading

Measuring accuracy / Flow range

YY = 01 (0.5%) 0.005 ... 2 L/min / (0.3%) 0.02 ... 2 L/min

03 (0.5%) 0.01 ... 10 L/min / (0.3%) 0.1 ... 10 L/min

05 (0.5%) 0.03 ... 40 L/min / (0.3%) 0.2 ... 40 L/min

07 (0.5%) 0.2 ... 120 L/min / (0.3%) 1 ... 120 L/min

Calibration viscosity

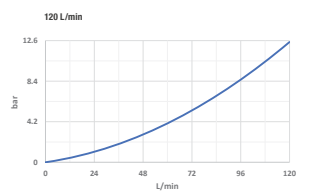
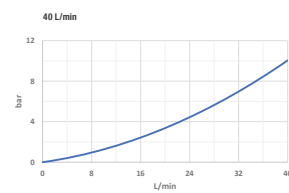
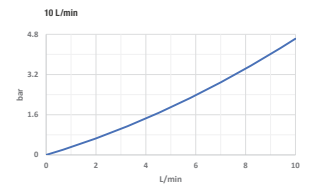
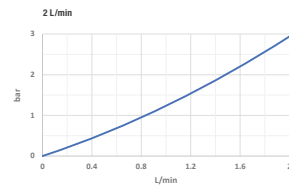
W = 1 → 30 mm²/s: ZZZ = 030W = A → 11 mm²/s: ZZZ = 011Pressure differential at 30 mm²/s

HySense® QL 1xx

The **HySense® QL** series was designed for development and diagnostic activities, and in particular to test the performance of pump units and determine pump characteristic curves. The series combines a turbine flow meter with an adjustable load valve, making it possible to conduct a defined load simulation in hydraulic systems.

The **HySense® QL 1xx** is sized for use with flow rates of up to 300 L/min and features a large hand valve that makes it possible to conveniently and precisely control the throttle valve.



A	MINIMESS® 1620 series p/T test point
B	HySense® RS series inductive sensor
C	MINIMESS® 1620 series test point
D	NG 20 throttle valve

General characteristics

Fluid	Fuels, hydraulic fluids, transmission fluids, brake fluid, Skydrol*
Flow range	9 ... 300 L/min*
Output signal	Frequency, CANopen, 4 ... 20 mA
Response time	< 0.05 s
Viscosity range	1 ... 150 mm ² /s (cSt) [†]
Measuring accuracy	±0.5% of reading
Fluid temperature	-20 °C ... 100 °C*
Ambient temperature	-20 ... 85 °C
Turbine housing material	Aluminum
Seal material	FKM*
IP degree of protection	IP67 (DIN EN 60529)

* More available upon request

Flow rate	Measuring range	G	Max. operating pressure	AF	Weight	Measuring accuracy
	L/min	DIN 13-7	bar	mm	g	QL 100 [‡] QL 106 QL 110 [‡]
300 L/min	9 ... 300	M30 × 2.0	350	55	Approx. 4300	±0.5% of reading

[†] Different if a constant calibration value is used; please refer to the technical data sheet

[‡] Additionally ±0.1% of full scale

Part No. 3WXT-71-35.ZZZ

Chemical compatibility

W = 1 Hydraulic fluids, transmission fluids
A Skydrol (available starting mid-2020)

Sensor

X = C QL 106 CAN, M12 electrical connector, 5-pin, ISDS
I QL 110 analog 4 ... 20 mA, M12 electrical connector, 4-pin, ISDS
J QL 110 analog 4 ... 20 mA, M16 electrical connector, 6-pin, ISDS
K QL 100 frequency, M12 electrical connector, 4-pin, ISDS
V QL 100 frequency, M16 electrical connector, 6-pin, ISDS

Calibration viscosity

W = 1 → 30 mm²/s: **ZZZ = 030**
A → 11 mm²/s: **ZZZ = 011**

Pressure differential at 30 mm²/s

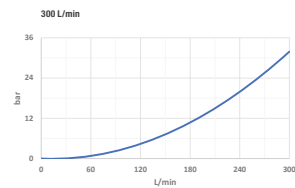

HySense® QL 2xx

The **HySense® QL 2xx** series is characterized by a compact and heavy-duty design, making it the ideal choice for portable applications. Moreover, it features a wide measuring range of up to 600 L/min.



A	Throttle valve for continuous pressure adjustments
B	MINIMESS® 1620 series test point
C	MINIMESS® 1620 series test point, plastic cap
D	HySense® RS series inductive sensor
E	MINIMESS® 1620 series p/T test point

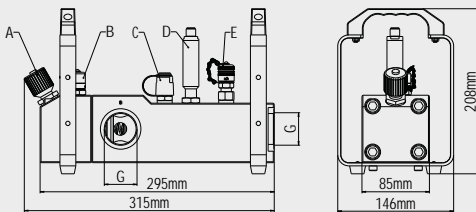

General characteristics

Fluid	Fuels, hydraulic fluids, transmission fluids, brake fluid, Skydrol*
Flow range	12 ... 600 L/min*
Output signal	Frequency, CANopen, 4 ... 20 mA
Response time	< 0.05 s
Viscosity range	1 ... 150 mm ² /s (cSt)*
Measuring accuracy	Up to ±0.5% of reading
Fluid temperature	-20 °C ... 100 °C*
Ambient temperature	-20 ... 85 °C
Turbine housing material	Aluminum
Seal material	FKM*
IP degree of protection	IP67 (DIN EN 60529)

* More available upon request

Flow rate L/min	Measuring range L/min	G ISO 228	Max. operating pressure bar	Weight g	Measuring accuracy		
					QL 200 ¹	QL 206	QL 210 ²
600 L/min	12 ... 600	G 1 1/4	350	Approx. 6520	±0.5% of reading		

¹ Different if a constant calibration value is used; please refer to the technical data sheet

² Additionally ±0.1% of full scale

Part No. 3WXQ-72-35.ZZZ

Chemical compatibility

W = 1 Hydraulic fluids, transmission fluids

A Skydrol (available starting mid-2020)

Sensor

X = C QL 206 CAN, M12 electrical connector, 5-pin, ISDS
I QL 210 analog 4 ... 20 mA, M12 electrical connector, 4-pin, ISDS
J QL 210 analog 4 ... 20 mA, M16 electrical connector, 6-pin, ISDS
K QL 200 frequency, M12 electrical connector, 4-pin, ISDS
V QL 200 frequency, M16 electrical connector, 6-pin, ISDS

Calibration viscosity

W = 1 — 30 mm²/s: **ZZZ = 030**

A — 11 mm²/s: **ZZZ = 011**

Pressure differential at 30 mm²/s

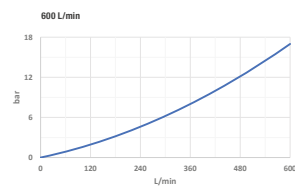

HySense® QL 326

The **HySense® QL 326** is our high-end product for load simulations. It not only features a compact heavy-duty design, but the load section also comes with a fully integrated proportional valve. When combined with the corresponding control unit, this product can be used to run predefined test sequences, such as a sine or ramp function, fully automatically.



NEW

A	Electrically actuated throttle valve
B	MINIMESS® 1620 series test point
C	MINIMESS® 1620 series test point, plastic cap
D	HySense® RS series inductive sensor
E	MINIMESS® 1620 series p/T test point
F	Control unit

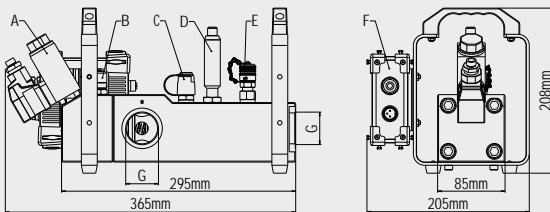

General characteristics

Fluid	Fuels, hydraulic fluids, transmission fluids, brake fluid, Skydrol*
Flow range	12 ... 600 L/min*
Control	Electric
Output signal	CANopen
Response time	< 0.05 s
Viscosity range	1 ... 150 mm ² /s (cSt)*
Fluid temperature	-20 °C ... 100 °C*
Ambient temperature	-20 ... 85 °C
Turbine housing material	Aluminum
Seal material	FKM*
IP degree of protection	IP54 (DIN EN 60529)

* More available upon request

Flow rate	Measuring range	G	Max. operating pressure	Weight	Measuring accuracy
	L/min	ISO 228	bar	g	
600 L/min	12 ... 600	G1 1/4	350	Approx. 7800	±0.5% of reading

Part No. 3WVR-72-P5.ZZZ

Chemical compatibility

W = 1	Hydraulic fluids, transmission fluids
A	Skydrol® (available starting mid 2020)

Calibration viscosity

W = 1	→	30 mm ² /s: ZZZ = 030
A	→	11 mm ² /s: ZZZ = 011

Scope of delivery
HySense® QL 326 included HySense® PR 126 pressure sensor

Pressure differential at 30 mm²/s

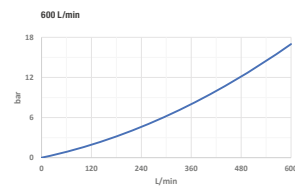

HySense® QO 400

The **HySense® QO 400** is a versatile oval gear flow meter that can be used to measure both volume and flow rate in machine building, plant automation, and process instrumentation applications. Its design and materials make it a perfect fit for use with corrosive fluids, acids, bases, solvents, and dyes. Moreover, its excellent chemical compatibility, combined with resistance to temperatures of up to 125 °C, make it the very definition of a high-end oval gear flow meter.



Actual product similar to picture

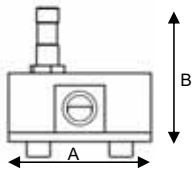

General characteristics

Fluid	Acids, bases, corrosive fluids, cleaning agents, coolant*
Flow range	0.03 ... 660 L/min
Output signal	PNP
Viscosity range	max. 3000 mPa·s
Measuring accuracy	±0.5% of reading
Fluid temperature	-40 °C ... 125 °C*
Ambient temperature	-40 °C ... 125 °C*
Max. operating pressure	68 bar
Housing material	Stainless steel*
Oval gear material	Stainless steel*
Seal material	FKM / EPDM*
Electrical measuring connector	Open cable end
IP degree of protection	IP67 (DIN EN 60529)

* More available upon request

Flow rate	Measuring range	G	A	Bmax	Part No.
	L/min <td>ISO 228 <td>mm <td>mm <td></td> </td></td></td>	ISO 228 <td>mm <td>mm <td></td> </td></td>	mm <td>mm <td></td> </td>	mm <td></td>	
1 L/min	0.03 ... 1	G 1/4	78	96	32EV-1A-10.00
5 L/min	0.2 ... 5	G 1/2	78	101	32EV-2B-10.00
30 L/min	1 ... 30	G 3/4	99	120	32EV-4C-10.00
100 L/min	4 ... 100	G 1	112	152	32EV-6D-10.00
300 L/min	3.0 ... 300	G 2	220	213	32EV-7E-10.00
660 L/min	35 ... 660	G 2	260	271	32EV-8E-10.00

The HySense® QO 400 will be available starting in mid-2020

Available in various versions upon request:

- | Additional output signals
- | Other flow ranges
- | Higher measuring accuracy
- | Other materials
- | Other calibration viscosities
- | With multi-function electronics (implemented display and output signal)



HySense® Q accessories

Sensors compatible with the HySense® Q family			
Model	Output signal	Electrical connector	Part No.
HySense® RS 310	Frequency	M16, 5-pin	3107-00-49.00
HySense® RS 300	Frequency, ISDS	M16, 6-pin	3107-00-S-49.00
HySense® RS 500	Frequency, ISDS	M16, 6-pin	3410-1600-A23F03
HySense® RS 500	Frequency, ISDS	M12, 4-pin	3410-1600-A21F07
HySense® RS 506	CANopen, ISDS	M12, 5-pin	3410-1400-A213C11
HySense® RS 510	4 ... 20 mA, ISDS	M16, 6-pin	3410-1400-A233Z1S
HySense® RS 510	4 ... 20 mA, ISDS	M12, 4-pin	3410-1400-A211Z13
HySense® SC 100	4 ... 20 mA, ISDS	M16, 6-pin	3410-6600-3433D1V

Cables compatible with the HySense® Q family			
Compatible with HySense®	Measuring device connection	Length m	Part No.
(M16 6-pol.) QT 200, 300, 400, 500, 600 QT 210, 310, 410, 510 QG 100, 200 QL 100, 200, 110, 210	M16, 6-pin	5	8824-S1-05.00S
	M16, 6-pin (high-end)	5	8824-S1-05.00H
	Unterminated cable end	5	8824-S6-05.00S
(M12 4-pol.) QT 200, 300, 400, 500, 600 QT 210, 310, 410, 510 QL 100, 200, 110, 210	M16, 6-pin	2.5	8824-V3-02.50S
	M12, 4-pin	2.5	8824-V2-02.50
	Unterminated cable end	2.5	8824-V1-02.50
QT 206, 306, 406, 506 QL 106, 206, 326	M12, 5-pin	5	8824-N3-05.00
	M12, 8-pin	5	8824-R7-05.00
	Unterminated cable end	5	8824-M8-05.00
QO 400	M12, 4-pin	2.5	8824-V2-02.50
	Unterminated cable end	2.5	8824-V1-02.50

For additional lengths and versions, please refer to page 226.

HySense® P

Pressure sensors, pressure switches,
and pressure gauges

HySense® P family

Needless to say, pressure is an extremely important and central consideration when it comes to fluid engineering and technology. Accordingly, pressure measurements are carried out for a broad variety of purposes, including adjusting systems and plants and carrying out fault diagnostics, maintenance and service work, and monitoring and development tasks. And with the **HySense® P family**, Hydretechnik has just the right pressure sensor, pressure switch, or pressure gauge for each of these needs.



Model	PR 1xx Pages 112 – 121	PR 126 Page 116	PR 400 Pages 122 – 123	PR 509 Pages 124 – 125	MultiEPC Pages 126 – 127	PS 280 Pages 128 – 129	Analog pressure gauges Pages 130 – 132	Digital pressure gauges Pages 133 – 134
Measuring range bar	-1 ... 6 0 ... 60 0 ... 250 0 ... 400 0 ... 600 0 ... 1000	0 ... 25 0 ... 50 0 ... 60 0 ... 400 0 ... 600	0 ... 60 0 ... 250 0 ... 400 0 ... 600	0 ... 60 0 ... 250 0 ... 400 0 ... 600	0 ... 25 0 ... 100 0 ... 250 0 ... 400	0 ... 1000	0 ... 10 0 ... 16 0 ... 25 0 ... 40 0 ... 60 0 ... 100 0 ... 160 0 ... 250 0 ... 400 0 ... 600	0 ... 60 0 ... 250 0 ... 600
Output signal More available upon request	4 ... 20 mA 0 ... 10 VDC	CANopen	4 ... 20 mA	4 ... 20 mA	4 ... 20 mA 0 ... 20 mA	PNP NPN	–	–
Electrical connector	M16 x 0.75, 6-pin M16 x 0.75, 5-pin M12 x 1, 5-pin M12 x 1, 4-pin Unterminated cable end Type A valve connector, 3-pin Type C valve connector, 3-pin	M12 x 1, 5-pin	M16 x 0.75, 6-pin	M16 x 0.75, 6-pin	M12 x 1, 5-pin	Can be freely chosen	–	–
Special characteristics	Hydrotechnik standard A wide variety of versions ISDS functionality Color coded	CANopen communications Heavy-duty design	High dynamic range, 10 kHz sampling rate High measuring accuracy ISDS functionality Color coded	Integrated measuring cable Extraordinary price-performance ratio Compact design	Freely adjustable switching values Integrated display Heavy-duty housing Switchable output signal	A wide variety of connector versions Integrated measuring cable	A wide variety of versions Large analog indicator Flush-mounted version also available Wide measuring range Available in kit	Large digital display Axially rotating display Available in kit

HySense® PR 1xx

HySense® PR 1xx is the Hydretechnik standard in the area of pressure measurement. These pressure sensors are perfect for both temporary diagnostic tasks and for stationary measuring tasks such as condition monitoring and predictive maintenance. Excellent strength, a wide measuring range of -1 to 2500 bar, and a wide variety of available versions make these pressure sensors all-rounders in every sense of the word.

General HySense® PR 1xx characteristics	
Sensor principle	Piezoresistivity
Pressure type	Relative pressure*
Measuring accuracy with ISDS @ 25 °C	±0.2% of full scale
Measuring accuracy without ISDS @ 25 °C	±0.5% of full scale
Overload range	2 x rated pressure (≤ 200 bar) 1.5 x rated pressure (> 200 ... 500 bar) 1.2 x rated pressure (> 500 ... 2000 bar)
Burst pressure	3 x rated pressure (≤ 200 bar) 2 x rated pressure (> 200 ... 500 bar) 1.5 x rated pressure (> 500 ... 2000 bar)
Body material	Stainless steel
Diaphragm material	Stainless steel or silicon
Sampling rate	1 kHz
Fluid temperature	-40 ... 125 °C
Ambient temperature	-40 ... 105 °C
Installation position	Any

* More available upon request

HySense® PR 100

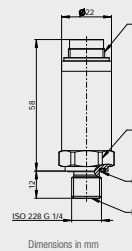

Dimensions in mm



A	M16 x 0.75, 6-pin
B	AF 22
C	ED seal in conformity with DIN 3869, FKM

Characteristics

Output signal	4 ... 20 mA, ISDS
Electrical connector	M16 x 0.75, 6-pin
Mechanical connection	ISO 228-G 1/4
IP degree of protection	IP67 (DIN EN 60529)
Weight	80 ... 100 g (depending on the version)

Measuring range* bar	Color coding	Part No.
-1 ... 6	Red	3403-32-S-E5.37
0 ... 60	Orange	3403-21-S-E5.37
0 ... 250	Yellow	3403-17-S-E5.37
0 ... 400	Blue	3403-15-S-E5.37
0 ... 600	Green	3403-18-S-E5.37
0 ... 1000	–	3403-29-S-E5.37

* More available upon request

HySense® PR 110

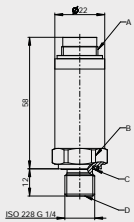

Dimensions in mm



A	M16 x 0.75, 5-pin
B	AF 22
C	ED seal in conformity with DIN 3869, FKM

Characteristics

Output signal	4 ... 20 mA, 0 ... 10 VDC
Electrical connector	M16 x 0.75, 5-pin
Mechanical connection	ISO 228-G 1/4
IP degree of protection	IP67 (DIN EN 60529)
Weight	80 ... 100 g (depending on the version)

Part No.

Measuring range* bar	Color coding	Part No.	
		4 ... 20 mA	0 ... 10 VDC
-1 ... 6	Red	3403-32-C3.37	-
0 ... 60	Orange	3403-21-C3.37	-
0 ... 250	Yellow	3403-17-C3.37	3403-17-C3.39
0 ... 400	Blue	3403-15-C3.37	3403-15-C3.39
0 ... 600	Green	3403-18-C3.37	3403-18-C3.39
0 ... 1000	-	3403-29-C3.37	-

* More available upon request

HySense® PR 120

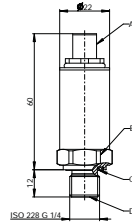

Dimensions in mm



A	M12 x 1, 5-pin
B	AF 22
C	ED seal in conformity with DIN 3869, FKM

Characteristics

Output signal	4 ... 20 mA, 0 ... 10 VDC
Electrical connector	M12 x 1, 5-pin
Mechanical connection	ISO 228-G 1/4
IP degree of protection	IP67 (DIN EN 60529)
Weight	80 ... 100 g (depending on the version)

Part No.

Measuring range* bar	Part No.	
	4 ... 20 mA	0 ... 10 VDC
0 ... 250	3403-17-D2.37	-
0 ... 400	-	3403-15-D2.39
0 ... 1000	3403-29-D2.37	-

* More available upon request

HySense® PR 126

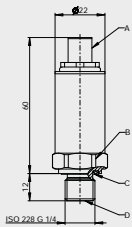

Dimensions in mm



A	M12 x 1, 5-pin
B	AF 22
C	ED seal in conformity with DIN 3869, FKM

Characteristics

Output signal	CANopen
Connector	M12 x 1, 5-pin
Sampling rate	ISO 228-G 1/4
IP degree of protection	IP67 (DIN EN 60529)
Weight	90 g

Measuring range*
bar

Part No.

0 ... 25	3403-40-T1.60
0 ... 50	3403-33-T1.60
0 ... 60	3403-21-T1.60
0 ... 400	3403-15-T1.60
0 ... 600	3403-18-T1.60

* More available upon request

HySense® PR 130 I5

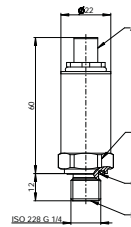

Dimensions in mm



A	M12 x 1, 4-pin
B	AF 22
C	ED seal in conformity with DIN 3869, FKM

Characteristics

Output signal	4 ... 20 mA, 0 ... 10 VDC
Electrical connector	M12 x 1, 4-pin
Mechanical connection	ISO 228-G 1/4
IP degree of protection	IP67 (DIN EN 60529)
Weight	80 ... 100 g (depending on the version)

Measuring range*
bar

Part No.

Measuring range* bar	Part No.	
	4 ... 20 mA	0 ... 10 VDC
-1 ... 6	3403-32-15.37S	3403-32-15.39S
0 ... 60	3403-21-15.37S	3403-21-15.39S
0 ... 250	3403-17-15.37S	3403-17-15.39S
0 ... 400	3403-15-15.37S	3403-15-15.39S
0 ... 600	3403-18-15.37S	3403-18-15.39S
0 ... 1000	3403-29-15.37S	3403-29-15.39S

* More available upon request

HySense® PR 140

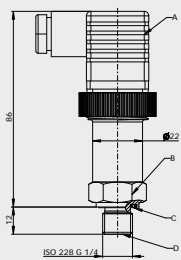

Dimensions in mm



A	Type A valve connector, 3-pin
B	AF 22
C	ED seal in conformity with DIN 3869, FKM

Characteristics

Output signal	4 ... 20 mA, 0 ... 10 VDC
Electrical connector	Type A valve connector, 3-pin
Mechanical connection	ISO 228-G 1/4
IP degree of protection	IP67 (DIN EN 60529)
Weight	170 g (depending on the version)

Part No.

Measuring range* bar	Part No.	
	4 ... 20 mA	0 ... 10 VDC
-1 ... 6	3403-32-D1.37S	3403-32-D1.39S
0 ... 60	3403-21-D1.37S	3403-21-D1.39S
0 ... 250	3403-17-D1.37S	3403-17-D1.39S
0 ... 400	3403-15-D1.37S	3403-15-D1.39S
0 ... 600	3403-18-D1.37S	3403-18-D1.39S
0 ... 1000	3403-29-D1.37S	—

* More available upon request

HySense® PR 150

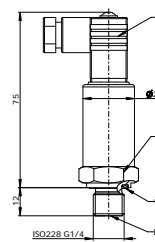

Dimensions in mm



A	Type C valve connector, 3-pin
B	AF 22
C	ED seal in conformity with DIN 3869, FKM

Characteristics

Output signal	4 ... 20 mA, 0 ... 10 VDC
Electrical connector	Type C valve connector, 3-pin
Mechanical connection	ISO 228-G 1/4
IP degree of protection	IP65 (DIN EN 60529)
Weight	170 g (depending on the version)

Part No.

Measuring range* bar	Part No.	
	4 ... 20 mA	0 ... 10 VDC
-1 ... 6	3403-32-D5.37S	—
0 ... 60	3403-21-D5.37S	—
0 ... 250	3403-17-D5.37S	3403-17-D5.39S
0 ... 400	3403-15-D5.37S	3403-15-D5.39S
0 ... 600	3403-18-D5.37S	3403-18-D5.39S
0 ... 1000	3403-29-D5.37S	3403-29-D5.39S

* More available upon request

HySense® PR 190

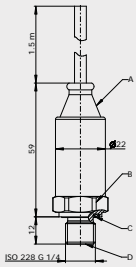

Dimensions in mm



A	Unterminated cable end
B	AF 22
C	ED seal in conformity with DIN 3869, FKM

Characteristics

Output signal	4 ... 20 mA, 0 ... 10 VDC
Electrical connector	Unterminated cable end
Mechanical connection	ISO 228-G 1/4
IP degree of protection	IP65 (DIN EN 60529)
Weight	170 g (depending on the version)

Part No.

Measuring range* bar	Color coding	Part No.	
		4 ... 20 mA	0 ... 10 VDC
-1 ... 6	Red	3403-32-D6.37S	3403-32-D6.39S
0 ... 60	Orange	3403-21-D6.37S	3403-21-D6.39S
0 ... 250	Yellow	3403-17-D6.37S	3403-17-D6.39S
0 ... 400	Blue	3403-15-D6.37S	-
0 ... 600	Green	3403-18-D6.37S	3403-18-D6.39S

* More available upon request

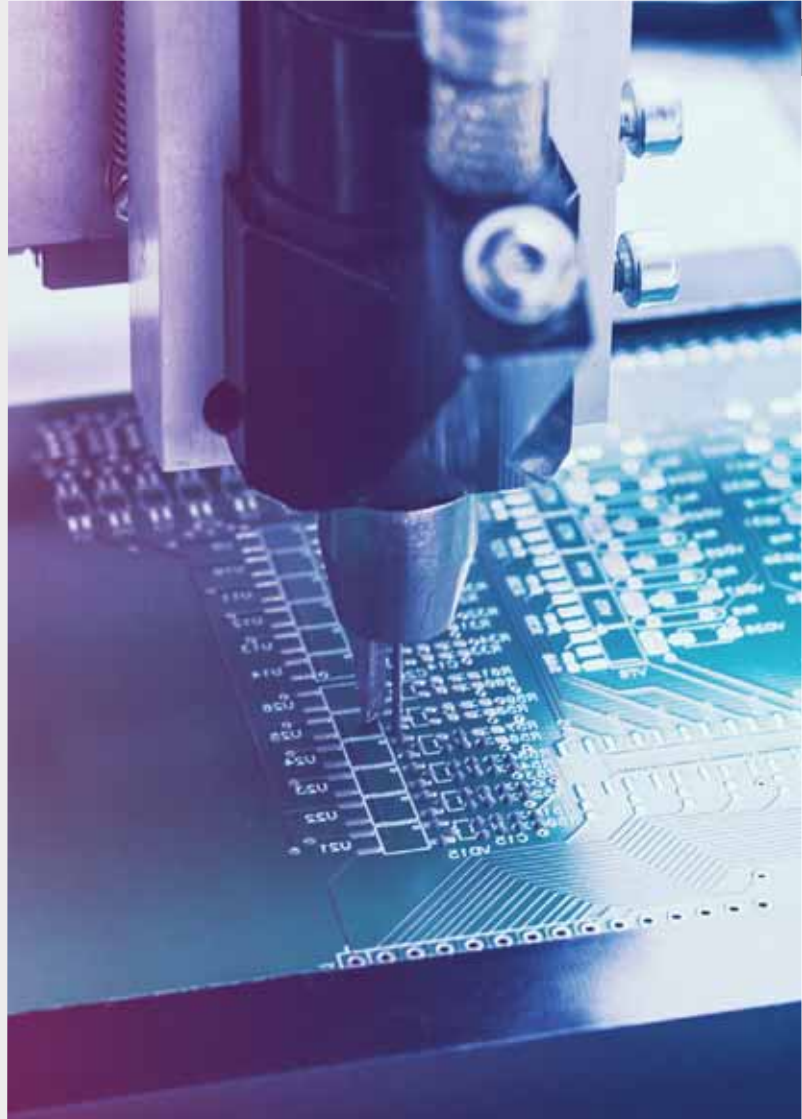

HySense® PR 400

The **HySense® PR 400** is a high-precision pressure sensor with a high dynamic range that was developed specifically for demanding and sophisticated measuring tasks in R&D, calibration laboratory, and high-precision measuring system applications. It is even able to measure dynamic shock at a high resolution thanks to a sampling rate of over 10 kHz.

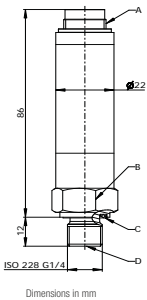

A	M16 x 0.75, 6-pin
B	AF 22
C	ED seal in conformity with DIN 3869, FKM

Dimensions in mm

General characteristics

Sensor principle	Piezoresistivity
Pressure type	Relative pressure
Measuring accuracy @ 25°C	±0.25% of full scale
Output signal	4 ... 20 mA, ISDS
Overload range	1.5 x rated pressure
Burst pressure	2.5 x rated pressure
Body material	Stainless steel
Diaphragm material	Stainless steel
Sampling rate	Up to 10 kHz
Fluid temperature	-40 ... 125 °C
Ambient temperature	-20 ... 80 °C
IP degree of protection	IP67 (DIN EN 60529)
Weight	140 g
Installation position	Any

Measuring range* bar

Measuring range* bar	Color coding	Part No.
0 ... 60	Orange	34P3-21-S-01.37A2
0 ... 250	Yellow	34P3-17-S-01.37A2
0 ... 400	Blue	34P3-15-S-01.37A2
0 ... 600	Green	34P3-18-S-01.37A2

* More available upon request

HySense® PR 509

The **HySense® PR 509** is a heavy-duty, compact pressure sensor with an unbeatable price-performance ratio. In addition, its integrated measuring cable makes it easy to quickly connect the sensor to an evaluation unit.

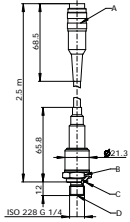

Dimensions in mm



A	M16 x 0.75, 6-pin
B	AF 22
C	ED seal in conformity with DIN 3869, FKM

General characteristics

Fluid temperature	-40 ... 150 °C
Ambient temperature	-25 ... 85 °C
IP degree of protection	IP67 (DIN EN 60529)
Weight	160 g, incl. cable
Installation position	Any

Measuring range*

Measuring range* bar	Color coding	Part No.
0 ... 60	Orange	3403-21-S-A1.37
0 ... 250	Yellow	3403-17-S-A1.37
0 ... 400	Blue	3403-15-S-A1.37
0 ... 600	Green	3403-18-S-A1.37

* More available upon request

General characteristics

Sensor principle	Piezoresistivity
Pressure type	Relative pressure
Measuring accuracy @ 25°C	±0.5% of full scale
Output signal	4 ... 20 mA, ISDS only with MultiHandy MH2025
Overload range	1.5 x rated pressure
Burst pressure	3 x rated pressure
Body material	Stainless steel
Diaphragm material	Stainless steel
Sampling rate	1 kHz



HySense® MultiEPC

The **HySense® MultiEPC** is an electronic pressure switch with an extraordinary level of functionality. It is available in standard and DESINA versions with one or two independently programmable limit switches. And to top it all off, the heavy-duty housing, which can rotate axially, features an integrated display.

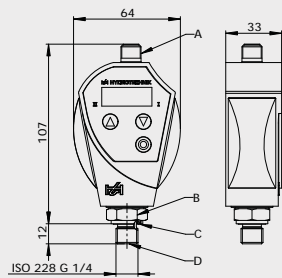

Dimensions in mm

A	M12 x 1, 5-pin
B	AF 22
C	ED seal in conformity with DIN 3869, FKM
D	ISO 228-G 1/4 A



General characteristics

Sensor principle	Piezoresistivity
Pressure type	Relative pressure
Measuring accuracy @ 25°C	±0.5% of full scale
Output signal	0 / 4 ... 20 mA
Switching output	Two high-side switching MOSFETs
Switching current	Max. 0.7 A
Body material	Die casting
Diaphragm material	Stainless steel
Sampling rate	100 Hz
Fluid temperature	-20 ... 85 °C
Ambient temperature	-20 ... 85 °C
IP degree of protection	IP67 (DIN EN 60529)
Weight	350 g
Installation position	Any

Measuring range

Measuring range bar	Part No.*
0 ... 25	3160-10-40.01
0 ... 100	3160-10-16.01
0 ... 250	3160-10-17.01
0 ... 400	3160-10-15.01
0 ... 700	3160-10-39.01

* DESINA version available upon request

HySense® PS 280

The high-precision **HySense® PS 280** pressure switch makes a compelling case with its compact design and a wide variety of configuration options. Various parameters, such as the pressure range, mechanical and electrical connections, cable length, pinout, signal output, function type, and switching value can be chosen freely, enabling customers to get the perfect solution for their specific measuring application.

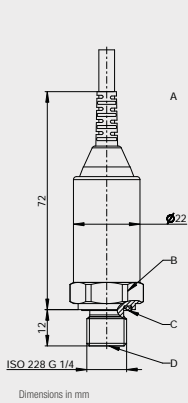

Dimensions in mm

A	Variable
B	AF 22
C	Depends on mechanical connection
D	Variable



General characteristics	
Sensor principle	Piezoresistivity
Pressure type	Relative pressure
Measuring accuracy @ 25°C	±0.5% of full scale
Body material	Stainless steel
Diaphragm material	Stainless steel
Fluid temperature	-40 ... 125 °C
Ambient temperature	-40 ... 105 °C
IP degree of protection	IP67 (DIN EN 60529)
Weight	Depends on the version
Installation position	Any

Variable parameters	
Pressure range	0 ... 1000 bar
Mechanical connection	Variable
Electrical connector	Variable
Seal type and material	Variable
Cable length	Variable
Number of switching outputs	1 or 2
Signal output	PNP or NPN
Function	NC or NO
Switching value	Variable, separate for rising and falling edges
Switching delay	Variable, 0 ... 7000 ms

HySense® analog pressure gauges

Analog pressure gauges are the simple and most cost-effective solution for a variety of pressure monitoring applications. Reliability and mechanical strength make these pressure gauges true all-rounders, and the fact that they combine an axially rotating indicator with a **MINIMESS®** gauge adapter ensures that readings can be conveniently read.



Dimensions in mm

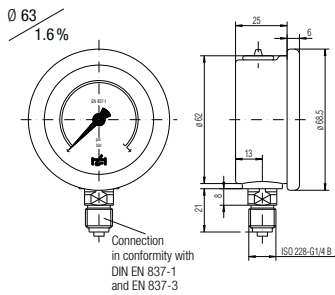

General characteristics

Case diameter	63 mm
Unit	bar & psi
Measuring accuracy	1.6% of full scale
Liquid filling	Silicone oil
Body material	Stainless steel
Connection direction	Down

Individual pressure gauges

Measuring range	Part No.
0 ... 10 bar (0 ... 145 psi)	9802-01-00.10
0 ... 16 bar (0 ... 230 psi)	9802-01-00.16
0 ... 25 bar (0 ... 360 psi)	9802-01-00.25
0 ... 40 bar (0 ... 580 psi)	9802-01-00.40
0 ... 60 bar (0 ... 870 psi)	9802-01-00.60
0 ... 100 bar (0 ... 1450 psi)	9802-01-01.00
0 ... 160 bar (0 ... 2300 psi)	9802-01-01.60
0 ... 250 bar (0 ... 3600 psi)	9802-01-02.50
0 ... 400 bar (0 ... 5800 psi)	9802-01-04.00
0 ... 600 bar (0 ... 8700 psi)	9802-01-06.00

Measuring box with one analog pressure gauge

Measuring range	Part No.
0 ... 10 bar (0 ... 145 psi)	3101-13-00.50
0 ... 16 bar (0 ... 230 psi)	3101-13-01.50
0 ... 25 bar (0 ... 360 psi)	3101-13-02.50
0 ... 40 bar (0 ... 580 psi)	3101-13-03.50
0 ... 60 bar (0 ... 870 psi)	3101-13-04.50
0 ... 100 bar (0 ... 1450 psi)	3101-13-05.50
0 ... 160 bar (0 ... 2300 psi)	3101-13-06.50
0 ... 250 bar (0 ... 3600 psi)	3101-13-07.50
0 ... 400 bar (0 ... 5800 psi)	3101-13-08.50
0 ... 600 bar (0 ... 8700 psi)	3101-13-09.50

HySense® digital pressure gauges

Digital pressure gauges are the ideal solution when it comes to taking on-site pressure measurements without having to connect to a power source. Accuracy, reliability, and mechanical strength make these pressure gauges true all-rounders. Moreover, they feature a min/max hold function and can be rotated axially as necessary in order to make it easier to read the display.

Measuring box with two analog pressure gauges		
Measuring range for pressure gauge 1	Measuring range for pressure gauge 2	Part No.
0 ... 10 bar (0 ... 145 psi)	0 ... 16 bar (0 ... 230 psi)	3101-14-01.50
0 ... 10 bar (0 ... 145 psi)	0 ... 25 bar (0 ... 360 psi)	3101-14-02.50
0 ... 10 bar (0 ... 145 psi)	0 ... 160 bar (0 ... 2300 psi)	3101-14-06.50
0 ... 10 bar (0 ... 145 psi)	0 ... 250 bar (0 ... 3600 psi)	3101-14-07.50
0 ... 16 bar (0 ... 230 psi)	0 ... 100 bar (0 ... 1450 psi)	3101-14-15.50
0 ... 16 bar (0 ... 230 psi)	0 ... 400 bar (0 ... 5800 psi)	3101-14-18.50
0 ... 25 bar (0 ... 360 psi)	0 ... 250 bar (0 ... 3600 psi)	3101-14-27.50
0 ... 25 bar (0 ... 360 psi)	0 ... 400 bar (0 ... 5800 psi)	3101-14-28.50
0 ... 40 bar (0 ... 580 psi)	0 ... 400 bar (0 ... 5800 psi)	3101-14-38.50
0 ... 60 bar (0 ... 870 psi)	0 ... 250 bar (0 ... 3600 psi)	3101-14-47.50
0 ... 60 bar (0 ... 870 psi)	0 ... 400 bar (0 ... 5800 psi)	3101-14-48.50
0 ... 100 bar (0 ... 1450 psi)	0 ... 250 bar (0 ... 3600 psi)	3101-14-57.50
0 ... 100 bar (0 ... 1450 psi)	0 ... 400 bar (0 ... 5800 psi)	3101-14-58.50
0 ... 160 bar (0 ... 2300 psi)	0 ... 250 bar (0 ... 3600 psi)	3101-14-67.50
0 ... 160 bar (0 ... 2300 psi)	0 ... 400 bar (0 ... 5800 psi)	3101-14-68.50
0 ... 250 bar (0 ... 3600 psi)	0 ... 400 bar (0 ... 5800 psi)	3101-14-78.50
0 ... 400 bar (0 ... 5800 psi)	0 ... 400 bar (0 ... 5800 psi)	3101-14-88.50
0 ... 600 bar (0 ... 8700 psi)	0 ... 600 bar (0 ... 8700 psi)	3101-14-99.50

Pressure gauge box without pressure gauges for MINIMESS® 1620 series	3101-1A-00.51
Pressure gauge box for MINIMESS® 1215 series	Available upon request
Pressure gauge box for MINIMESS® 1615 series	Available upon request
MINIMESS® 1620 series gauge adapter	2103-07-11.62N
MINIMESS® 1615 series gauge adapter	2102-07-11.62N

Flush-mount pressure gauges with a connector on the back are available upon request for various pressure ranges.



Dimensions in mm

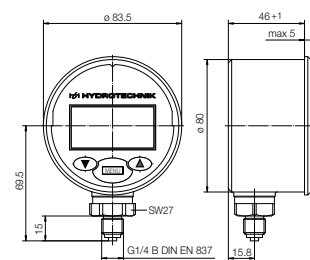

Can rotate axially

General characteristics

Case diameter	70 mm
Unit	bar / psi / MPa
Measuring accuracy	0.5% of full scale, ± 1 digit
Liquid filling	Silicone oil
Body material	Stainless steel
Conversion rate	5/s
Display	Four-digit seven-segment LCD display, 11 mm, plus bargraph display with 10 segments
Hold function	Min/max
IP degree of protection	IP67 (DIN EN 60529)
Weight	Approx. 400 g

Individual pressure gauges

Measuring range	Part No.
0 ... 60 bar (0 ... 870 psi)	9801-99-00.60
0 ... 250 bar (0 ... 3600 psi)	9801-99-02.50
0 ... 600 bar (0 ... 8700 psi)	9801-99-06.00

Measuring box with one digital pressure gauge

Measuring range	Part No.
0 ... 60 bar (0 ... 870 psi)	3101-86-04.50
0 ... 250 bar (0 ... 3600 psi)	3101-86-06.50
0 ... 600 bar (0 ... 8700 psi)	3101-86-09.50

Measuring box with two digital pressure gauges

Measuring range for pressure gauge 1	Measuring range for pressure gauge 2	Part No.
0 ... 60 bar (0 ... 870 psi)	0 ... 60 bar (0 ... 870 psi)	3101-87-44.50
0 ... 250 bar (0 ... 3600 psi)	0 ... 250 bar (0 ... 3600 psi)	3101-87-66.50
0 ... 600 bar (0 ... 8700 psi)	0 ... 600 bar (0 ... 8700 psi)	3101-87-99.50

Pressure gauge box without pressure gauges for MINIMESS® 1620 series

3101-1D-00.51

Pressure gauge shock protection

9800-00-00.10

HySense® custom solutions

Both highly complex measuring tasks and highly specific measuring tasks require the use of custom solutions that often go beyond what a standard product portfolio has to offer. This is why we at Hydrotechnik have made it one of our core focuses to implement custom solutions with unparalleled quality in order to meet our customers' specific needs. Following are a couple of examples:

HySense® PR 130 - J5

High-pressure version with an M16 x 1.5 female thread for pressures of up to 2000 bar

**HySense® PR 180 - G6**

Custom version with an AMP bayonet circular connector (3-pin) and a 1 ... 5 V output signal

**HySense® PR 280**

Special miniature sensor, perfect for use in places where space is extremely tight, such as directional control valves



HySense® P accessories

Available electrical connectors

M16 x 0.75, 7-pin	Type A valve connector, 3-pin
M16 x 0.75, 6-pin	Type C valve connector, 3-pin
M16 x 0.75, 5-pin	Hirschmann G Series valve connector, 4-pin
M12 x 1, 5-pin	Bayonet circular connector, keying 1, 3-pin
M12 x 1, 4-pin	More available upon request
Unterminated cable end	

Available output signals

4 ... 20 mA	1 ... 5 VDC
0 ... 20 mA	1 ... 6 VDC
0 ... 10 mA	0 ... 10 VDC
0.5 ... 4.5 VDC (ratiometric)	0.2 ... 1.6 kHz
0 ... 5 VDC	CANopen

Available pressure ranges

-1 ... 6	0 ... 400
0 ... 1	0 ... 600
0 ... 10	0 ... 1000
0 ... 25	0 ... 2000
0 ... 60	0 ... 2500
0 ... 100	0 ... 4000
0 ... 250	

Available mechanical connections

ISO 228-G 1/4 A	M16 x 1.5 female thread
ISO 228-G 1/2	M18 x 1.5
M8 x 1	

Cables compatible with the HySense® P family

Compatible with HySense®	Measuring device connection	Length m	Part No.
PR 100	M16, 6-pin	5	8824-S1-05.00S
PR 400	M16, 6-pin (high-end)	5	8824-S1-05.00H
PR 509	Unterminated cable end	5	8824-S6-05.00S
PR 126	M12, 5-pin	5	8824-N3-05.00
	M12, 8-pin	5	8824-R7-05.00
	Unterminated cable end	5	8824-M8-05.00
PR 130 (4 ... 20 mA)	M16, 6-pin	2.5	8824-V3-02.50S
	M12, 4-pin	2.5	8824-V2-02.50
	Unterminated cable end	2.5	8824-V1-02.50
MultiEPC	Unterminated cable end	5	8824-L0-05.00

For additional lengths and versions, please refer to page 226.

HySense® T Temperature sensors

HySense® T family

With the **HySense® T** family, Hydrotechnik offers high-quality sensors for temperature measurements in liquids, gases, and solids. The products in this family are based on a modular system, meaning that custom solutions can be implemented quickly and easily. In fact, decades of experience have resulted in Hydrotechnik having a patented solution for temporary temperature measurements in closed systems. A MINIMESS® p/T test point can be used to install temperature sensors in a system under pressure without any leaks.

HySense® TE 200

The **HySense® TE 200** is an all-purpose handheld temperature sensor that can be used for an extremely wide range of measuring tasks, such as measuring temperatures in fluids and powders, as well as on surfaces. The long probe and the flexible coil cord make it easy to quickly measure temperatures even at locations that are difficult to access.



General characteristics	
Sensor principle	Pt100
Measuring range	-50 ... 400 °C
Output signal	4 ... 20 mA, ISDS
Mechanical measuring connection	Immersion and surface probe
Electrical measuring connector	M16 x 0.75, 6-pin*
Measuring accuracy	1% of full scale
Ambient temperature	-40 ... 70 °C
Body material	Plastic
Probe tip material	Stainless steel
Weight	207 g
IP degree of protection	IP40 (DIN EN 60529)

* More available upon request

Sensor	Model	Temperature range	Part No.
HySense® TE 200	Surface probe	-50 ... 200 °C	3170-01-S-03.00
		-50 ... 400 °C	3170-01-S-07.00
	Immersion probe	-50 ... 200 °C	3170-02-S-06.00
		-50 ... 400 °C	3170-02-S-08.00

Sensor	Measuring range	Electrical connector	Output signal	Mechanical connection	Probe length	Probe diameter	Part No.
	C°				mm	mm	
TE 300	-50 ... 200	M16 x 0.75 6-pin	4 ... 20 mA, ISDS	MINIMESS® 1620 p/T test point direct sensor adapter	–	2	3408-2200-D631Z1S
				MINIMESS® 1615 p/T test point direct sensor adapter	–	2	3408-2200-D731Z1S
				ISO 228-G 1/4	26	3.3	3408-2300-G231Z1S
				M10 x 1	20	4	3408-2410-M331Z1S

Sensor	Measuring range	Electrical connector	Output signal	Mechanical connection	Probe length	Probe diameter	Part No.
	C°				mm	mm	
TE 330	-50 ... 200	M12 x 1, 4-pin	0 ... 10 VDC	MINIMESS® 1620 p/T test point direct sensor adapter	–	2	3408-2200-D611D47
			4 ... 20 mA	MINIMESS® 1620 p/T test point direct sensor adapter	–	2	3408-2200-D611Z13
			0 ... 10 VDC	ISO 228-G 1/4*	26	3.3	3408-2300-G211D47
			4 ... 20 mA	ISO 228-G 1/4*	26	3.3	3408-2300-G211Z13
			0 ... 10 VDC	ISO 228-G 1/4	20	4	3408-2410-G211D47
			4 ... 20 mA	ISO 228-G 1/4	40	4	3408-2420-G211Z13
			0 ... 10 VDC	M10 x 1	60	4	3408-2430-M311D47
			4 ... 20 mA	ISO 228-G 1/4	250	4	3408-2470-G211Z13
			4 ... 20 mA	ISO 228-G 1/4	200	6	3408-2660-G211Z13

* Substitute for MINIMESS® p/T test point

Sensor	Measuring range	Electrical connector	Output signal	Mechanical connection	Probe length	Probe diameter	Part No.
	C°				mm	mm	
TE 350	-50 ... 200	Type C valve connector, 3-pin Pg9	4 ... 20 mA	ISO 228-G 1/4	26	3.3	3408-2300-G2C3Z11

Sensor	Measuring range	Electrical connector	Output signal	Mechanical connection	Probe length	Probe diameter	Part No.
	C°				mm	mm	
TE 380	-50 ... 200	AMP DIN 72585, 3-pin	4 ... 20 mA	MINIMESS® 1620 p/T test point direct sensor adapter	–	2	3408-2200-D6R1Z12

HySense® TE 400

The HySense® TE 400 is a high-precision surface thermometer that can be attached to metal surfaces quickly and easily with the help of its integrated permanent magnet.



General characteristics	
Sensor principle	Pt100
Measuring range	-30 ... 70 °C
Output signal	4 ... 20 mA, ISDS
Mechanical measuring connection	Permanent magnet
Electrical measuring connector	M16 x 0.75, 6-pin*
Measuring accuracy @ 25°C	1% of full scale
Ambient temperature	-40 ... 85 °C
Body material	Stainless steel
Weight	145 g
IP degree of protection	IP67 (DIN EN 60529)

* More available upon request

Sensor	Temperature range	Part No.
HySense® TE 400	-30 ... 70 °C	3408-06H0-0131Z1S

HySense® TP 180

The **HySense® TP 180** is a high-precision dual sensor that measures both temperature and pressure at the same measuring point simultaneously. When combined with a **MINIMESS®** p/T test point, a fast and simple connection to the fluid can be established without any system downtimes. Moreover, direct contact with the fluid ensures that high-precision, dynamic temperature and pressure measurements can be carried out.

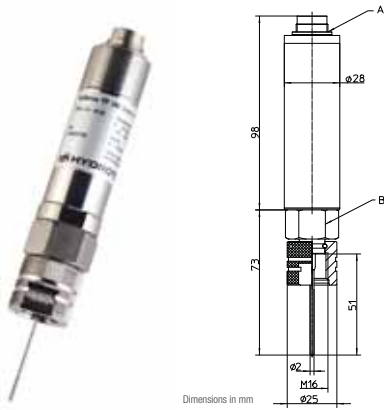

Dimensions in mm

General characteristics	
Sensor principle	Temperature: Pt100, pressure: Piezoresistive effect
Measuring range	-50 ... 200 °C, 0 ... 600 bar
Output signal	4 ... 20 mA
Mechanical measuring connection	For MINIMESS® 1620 p/T test point
Electrical measuring connector	M16 x 0.75, 8-pin
Measuring accuracy @ 25°C	Temperature: 0.5% of full scale; pressure: ±0.5% of full scale
Ambient temperature	-35 ... 100 °C
Body material	Stainless steel
Probe tip material	Stainless steel
Weight	260 g
IP degree of protection	IP65 (DIN EN 60529)

* More available upon request

Sensor	Temperature range	Pressure range	Part No.
HySense® TP 180	-50 ... 200 °C	0 ... 10 bar	3763-08-34.00
		0 ... 60 bar	3763-04-34.00
		0 ... 600 bar	3763-03-34.00

HySense® T accessories

Cables compatible with the HySense® T family

Compatible with HySense®	Measuring device connection	Length (m)	Part No.
TE 200	M16, 6-pin	5	8824-S1-05.00S
TE 300	M16, 6-pin (high-end)	5	8824-S1-05.00H
TE 400	Unterminated cable end	5	8824-S6-05.00S
TE 330 (4 ... 20 mA)	M16, 6-pin	2.5	8824-V3-02.50S
	M12, 4-pin	2.5	8824-V2-02.50
	Unterminated cable end	2.5	8824-V1-02.50
TP 180	M16, 5-pin 2x	5	8824-D6-05.00

For additional lengths and versions, please refer to page 226

HySense® C Oil condition sensors





HySense® C family

Needless to say, one thing that users want to avoid at all costs are system failures and downtimes, which is why it is crucial to be one step ahead and use preventive measures instead. Moreover, an additional trend is the change from interval-based maintenance, which is often unnecessary and costly, to condition-based maintenance instead. So what does this mean? Among other things, that being aware of the condition of the oil in hydraulic systems is absolutely vital. That is precisely the type of diagnostic and monitoring tasks for which the **HySense® C** family was developed. These high intelligence sensors are able not only to measure oil condition parameters, but also to evaluate them based on condition algorithms. The result? Users can get easy-to-understand information regarding condition changes over time and, for example, the oil's remaining life.

In addition to this, Hydrotechnik has implemented an analysis application in MultiSystem measuring devices that is designed to help the user with data acquisition, through the visualization and evaluation of measured results, all the way to generating reports.

By combining the condition sensors in the **HySense® C** family with the measuring devices in the MultiSystem series, users can get the perfect all-in-one solution for precise and simple oil condition monitoring.

Oil condition sensor overview

	HySense®				
	CL 1xx	CM 100	CV 100	CX 197	CW 100
Contamination (number of particles)				x	
Viscosity			x	x	
Rel. humidity	x	x		x	
Rel. permittivity	x	x	x	x	
Conductivity	x	x		x	
Temperature	x	x	x	x	
Fill level	x				
Wear (ferromagnetic particles)					x
					



Product discontinued

HySense® CL 1xx

The **HySense® CL 1xx** is a high intelligence sensor that not only determines oil level precisely, but also measures the following oil condition parameters: relative humidity, relative permittivity, conductivity, and temperature. After a calibration phase, this sensor can evaluate an oil's condition and output it based on implemented condition algorithms. Moreover, the corresponding analysis application that is implemented in MultiSystem measuring devices makes it enormously easier to operate and use the sensors. Finally, the intuitive menu navigation and the stored oil database both make it easy to quickly acquire, visualize, evaluate, and store oil condition parameters.

Advantages when combined with MultiSystem measuring devices.

- I Database for storing data for specific systems and measuring points
- I Access to an integrated oil database
- I The ability to define limits
- I The ability to visualize conditions with a traffic light pattern
- I The ability to store readings
- I The ability to display histories
- I The ability to export readings via USB
- I Report template

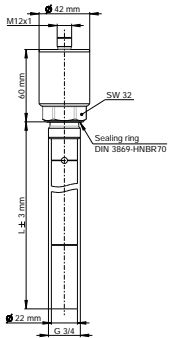

Sensor	L mm	Part No.
HySense® CL 120	200	3402-CL12-6926C0-000
HySense® CL 130	375	3402-CL13-6926C0-000
HySense® CL 160	615	3402-CL16-6926C0-000

General characteristics	
Fluid	Mineral oils (H, HL, HLP, HLPD, HVLP), synthetic esters (HETG, HEPG, HEES, HEPR), polyalkylene glycols (PAG), zinc-free ash-free fluids (ZAF), polyalphaolefins (PAO)*
Measured variables	Level, rel. humidity, rel. permittivity, conductivity, temperature
Immersion length	200 mm / 375 mm / 615 mm
Interfaces	RS-232, CANopen, 4 ... 20 mA
Electrical connector	M12 A 8p m
Max. operating pressure	50 bar
IP degree of protection	IP67 (DIN EN 60529)
Operating temperature	-20 ... 85 °C
Seal material	HNBR

Measured variable	Measuring range	Measuring accuracy
Rel. permittivity	1 ... 7	± 0.015
Rel. humidity	0 ... 100% r.H.	$\pm 3\%$ r.H. @ (10 ... 90%) $\pm 5\%$ r.H. @ (< 10%, > 90%)
Conductivity	100 ... 800,000 pS/m	$< \pm 10\%$ @ (2000 ... 800,000 pS/m) $\pm 200 \text{ pS/m}$ @ (100 ... 2000 pS/m)
Fill level	115 mm / 288 mm / 515 mm	$\pm 5\%$
Temperature	-20 ... 85 °C	$\pm 2 \text{ }^\circ\text{C}$

HySense® CM 100

The **HySense® CM100** is a high intelligence sensor that measures the following oil condition parameters: relative humidity, relative permittivity, conductivity, and temperature. After a calibration phase, this sensor can evaluate an oil's condition and output it based on implemented condition algorithms. Moreover, the corresponding analysis application that is implemented in MultiSystem measuring devices makes it enormously easier to operate and use the sensors. Finally, the intuitive menu navigation and the stored oil database both make it easy to quickly acquire, visualize, evaluate, and store oil condition parameters.

Advantages when combined with MultiSystem measuring devices.

- I Database for storing data for specific systems and measuring points
- I Access to an integrated oil database
- I The ability to define limits
- I The ability to visualize conditions with a traffic light pattern
- I The ability to store readings
- I The ability to display histories
- I The ability to export readings via USB
- I Report template

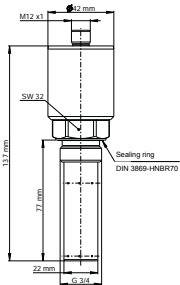

Sensor	Part No.
HySense® CM 100	3402-CM10-G926C0-000
Screw-in block	3109-20-05.01

General characteristics	
Fluid	Mineral oils (H, HL, HLP, HLPD, HVLP), synthetic esters (HETG, HEPG, HEES, HEPR), polyalkylene glycols (PAG), zinc-free ash-free fluids (ZAF), polyalphaolefins (PAO)*
Measured variables	Rel. humidity, rel. permittivity, conductivity, temperature
Interfaces	RS-232, CANopen, 4 ... 20 mA
Electrical connector	M12 A 8p m
Max. operating pressure	50 bar
IP degree of protection	IP67 (DIN EN 60529)
Operating temperature	-20 ... 85 °C
Seal material	HNBR

Measured variable	Measuring range	Measuring accuracy
Rel. permittivity	1 ... 7	±0.015
Rel. humidity	0 ... 100% r.H.	±3% r.H. @ (10 ... 90%) ±5% r.H. @ (< 10%, > 90%)
Conductivity	100 ... 800,000 µS/m	< ±10% @ (2000 ... 800,000 µS/m) ±200 µS/m @ (100 ... 2000 µS/m)
Temperature	-20 ... 85 °C	±2 °C

HySense® CV 100

The **HySense® CV 100** is a high intelligence sensor that measures the following oil condition parameters: viscosity, relative permittivity, and temperature. After a calibration phase, this sensor can evaluate an oil's condition and output it based on implemented condition algorithms. Moreover, the corresponding analysis application that is implemented in MultiSystem measuring devices makes it enormously easier to operate and use the sensors. Finally, the intuitive menu navigation and the stored oil database both make it easy to quickly acquire, visualize, evaluate, and store oil condition parameters.

Advantages when combined with MultiSystem measuring devices.

- I Database for storing data for specific systems and measuring points
- I Access to an integrated oil database
- I The ability to define limits
- I The ability to visualize conditions with a traffic light pattern
- I The ability to store readings
- I The ability to display histories
- I The ability to export readings via USB
- I Report template

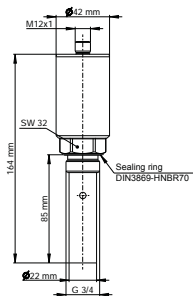

Sensor	Part No.
HySense® CV 100	3402-CV10-G928C0-000 Product discontinued
Screw-in block	3109-20-05.01

General characteristics	
Fluid	Mineral oils (H, HL, HLP, HLPD, HVLP), synthetic esters (HETG, HEPG, HEES, HEPR), polyalkylene glycols (PAG), zinc-free ash-free fluids (ZAF), polyalphaolefins (PAO)*
Measured variables	Viscosity, rel. permittivity, temperature
Interfaces	RS-232, CANopen, 4 ... 20 mA
Electrical connector	M12 A 8p m
Max. operating pressure	50 bar
IP degree of protection	IP67 (DIN EN 60529)
Operating temperature	-20 ... 85 °C
Seal material	HNBR

Measured variable	Measuring range	Measuring accuracy
Rel. permittivity	1 ... 7	± 0.02
Viscosity	8 ... 400 mm ² /s	± 5 mm ² /s @ (8 ... 100 mm ² /s) $\pm 5\%$ @ (100 ... 400 mm ² /s)
Temperature	-20 ... 85 °C	± 0.5 °C

HySense® CX 197

The **HySense® CX 197** service measuring kit combines all the oil condition sensors needed for a professional and fast oil condition analysis. As a result of its heavy-duty construction and compact design, combined with **MINIMESS®** adapters that make setup an absolute breeze, this kit is a perfect fit for mobile use. Moreover, the corresponding analysis application that is implemented in MultiSystem measuring devices makes it enormously easier to operate and use the sensors. Finally, the intuitive menu navigation and the stored oil database both make it easy to quickly acquire, visualize, evaluate, and store oil condition parameters.



NEW

A	MINIMESS® 1620 series test point
B	HySense® Patrick
C	HySense® CM 100
D	HySense® CV 100

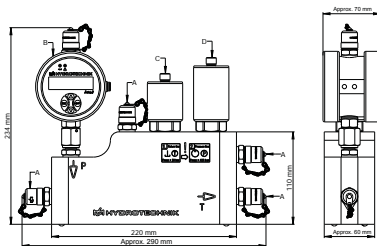

General characteristics	
Fluid	Mineral oils (H, HL, HLP, HLPD, HVLP), synthetic esters (HETG, HEPG, HEES, HEPR), polyalkylene glycols (PAG), zinc-free ash-free fluids (ZAF), polyalphaolefins (PAO)*
Measured variables	Number of particles, viscosity, rel. humidity, rel. permittivity, conductivity, temperature
Interfaces	RS-232, CANopen, 4 ... 20 mA
Electrical connector	M12 A 8p m
Max. operating pressure	45 bar
IP degree of protection	IP67 (DIN EN 60529)
Operating temperature	-20 ... 85 °C
Seal material	HNBR

Measured variable	Measuring range	Measuring accuracy
Viscosity	8 ... 400 mm ² /s	±5 mm ² /s @ (8 ... 100 mm ² /s) ±5% @ (100 ... 400 mm ² /s)
Rel. permittivity	1 ... 7	±0.02
Rel. humidity	0 ... 100% r.H.	±3% r.H. @ (10 ... 90%) ±5% r.H. @ (< 10%, > 90%)
Conductivity	100 ... 800,000 pS/m	< ±10% @ (2000 ... 800,000 pS/m) ±200 pS/m @ (100 ... 2000 pS/m)
Temperature	-20 ... 85 °C	±0.5 °C
ISO 4406:99 particle code	6 ... 24 10 ... 22 (calibrated)	±1 (ordinal number)

Sensor	Part No.
HySense® CX 197	3402-CX10-D100-000

HySense® CW 100

The **HySense® CW 100** is a high intelligence sensor that detects wear in the form of ferromagnetic particles. In addition, it is able to determine whether the particles are fine particles in the micrometer range or coarse particles in the millimeter range. Finally, this sensor has a fully automatic particle release function that eliminates the need to clean or maintain it.

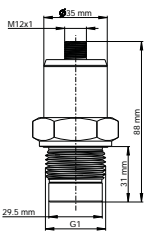

General characteristics

Fluid	Mineral oils (H, HL, HLP, HLPD, HVL), synthetic esters (HETG, HEPG, HEES, HEPR), polyalkylene glycols (PAG), zinc-free ash-free fluids (ZAF), polyalphaolefins (PAO)*
Measured variables	Ferromagnetic particles – Fine particles (µm range) – Coarse particles (mm range)
Interfaces	RS-232, CANopen, 4 ... 20 mA
Electrical connector	M12 A 8p m
Max. operating pressure	20 bar
IP degree of protection	IP67 (DIN EN 60529)
Operating temperature	-20 ... 85 °C
Seal material	HNBR

Measured variable

Measured variable	Measuring range	Measuring accuracy
Fine particles (µm range)	0 ... 100%	0.1%
Coarse particles (mm range)	1 ... 10	1

HySense® C accessories

Cables compatible with the HySense® C family

Compatible with HySense®	Measuring device connection	Length m	Part No.
CL 120, 130, 160	M12, 8-pin	5	8824-T6-05.00
CM 100			
CV 100	Unterminated cable end	2.5	8824-T1-05.00
CW 100			
CX 197	M12, 8-pin	1.5	8824-TB-00.00

For additional lengths and versions, please refer to page 226

Sensor	Part No.
HySense® CW 100	3402-CW10-G326C0-000

HySense® FO | TQ | RS | PO | VB | SC

FORCE | TORQUE | SPEED | POSITION | VIBRATION | TRANSDUCERS

HySense® FO 200

The **HySense® FO 200** is an all-purpose strain gauge tension load cell that detects longitudinal and transverse strain and uses it to determine the corresponding forces. The threaded rod design makes it easy to quickly integrate the load cell into systems, and the compact and lightweight construction are important advantages in comparison to other standard tension load cells.

Typical applications:

- I Maximum construction machinery and harvester tensile forces
- I Forces in belt tensioners and Bowden cables
- I Tensile forces in universal testing machines
- I Wire rope and spring force measurements
- I Production process monitoring and documentation
- I Tensile forces on cranes, cable cars, elevators



Actual product similar to picture

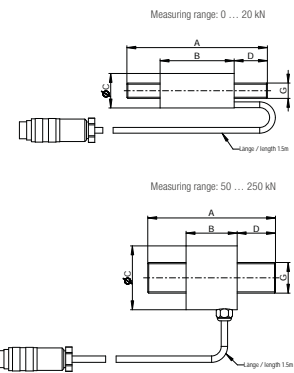

General characteristics

Sensor principle	Strain gauge
Measured variable	Tensile force
Output signal	4 ... 20 mA, ISDS
Nonlinearity	< 0.25% of full scale
Hysteresis	< 0.15% of full scale
Electrical connector	M16 x 0.75, 6-pin
Body material	Steel
Ambient temperature	-15 ... 85 °C
IP degree of protection	IP65 (DIN EN 60529)

Measuring range kN	A mm	B mm	Ø C mm	D mm	G mm	Weight g	Part No.
0 ... 5	110	58	27	26	M12	170	34G8-1508-33Z1S
0 ... 10							34G8-2108-33Z1S
0 ... 20	100	40	40	30	M16 x 1.5	310	34G8-2208-33Z1S
0 ... 50							34G8-2508-33Z1S
0 ... 100							34G8-3108-33Z1S
0 ... 150							34G8-3158-33Z1S
0 ... 250	140	56	60	40	M36 x 2	1380	34G8-3258-33Z1S

Matching eye bolts available upon request

HySense® FO 300

As a result of its small and extremely slim design, the **HySense® FO 300** load cell is an ideal choice for applications where there is barely any room to work with. Moreover, its special housing geometry and stainless steel housing material mean that it can be used in harsh environments.

Typical applications:

- I Fully automated production centers
- I Measuring and monitoring systems
- I Production process monitoring
- I Toolmaking
- I Universal testing machines

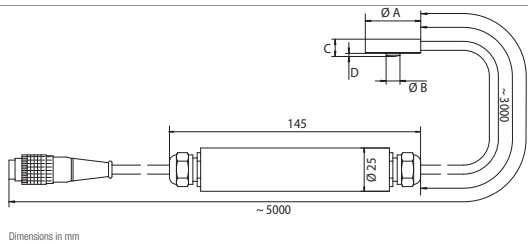

General characteristics	
Sensor principle	Strain gauge
Measured variable	Compressive force
Measuring range	1 ... 100 kN
Output signal	4 ... 20 mA, ISDS
Measuring accuracy @ 23 °C	±0.5% of full scale
Electrical connector	M16 x 0.75, 6-pin
Body material	Stainless steel
Ambient temperature	-30 ... 80 °C
IP degree of protection	IP65 (DIN EN 60529)
Max. displacement	≤ 0.15 mm

Measuring range kN	Ø A mm	Ø B mm	C mm	D mm	Weight g	Part No.
0 ... 1	32	8	10	1.5	Approx. 380	34D8-1108-33Z1S
0 ... 2						34D8-1208-33Z1S
0 ... 5						34D8-1508-33Z1S
0 ... 10						34D8-2108-33Z1S
0 ... 20	39	11	16	2	Approx. 450	34D8-2208-33Z1S
0 ... 50	52	15	25	3	Approx. 750	34D8-2508-33Z1S
0 ... 100	79	20	39	5	Approx. 1500	34D8-3108-33Z1S



HySense® TQ 100

The **HySense® TQ 100** is a rotating torque sensor with integrated direction detection that was developed both for temporary and permanent use. It features high-quality, low-wear slip rings that make it possible to achieve precise and stable signal transmission. In addition, the feather keys on both sides and the housing design make direct mounting fast and easy.

Typical applications:

- I Measuring constant and varying torques
- I Friction torque in gearing and bearings
- I Measurements on rotating shafts
- I Production process monitoring and documentation
- I Testing and adjusting screw/nut drivers
- I A wide variety of adjustment devices in the industry

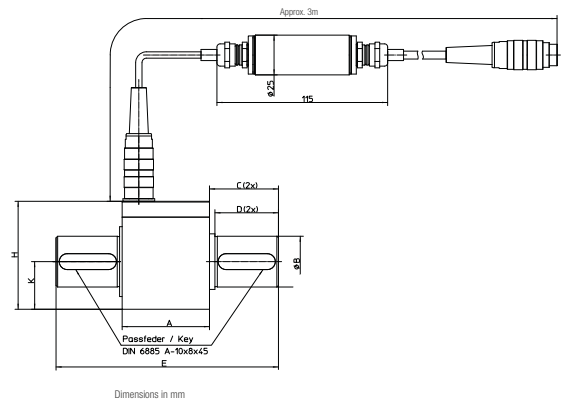

General characteristics

Sensor principle	Strain gauge, slip ring
Measured variable	Torque
Measuring range	1 ... 500 Nm
Output signal	12 ±8 mA ISDS
Measuring accuracy	0.1% of full scale
Electrical connector	M16 x 0.75, 6-pin
Ambient temperature	-10 ... 60 °C
IP degree of protection	IP50 (DIN EN 60529)

Measuring range Nm	Ø B mm	C mm	D mm	E mm	K mm	H mm	Weight g	Part No.
±1	8	19.7	18	85	12	39	200	3417-1102-33R1S
±5								3417-1502-33R1S
±50	15	21	20	90	21	54	400	3417-2502-33R1S
±100	18	24.1	22	95	21	54	500	3417-3102-33R1S
±200								3417-3202-33R1S
±500	32	41.6	40	140	30	68	1300	3417-3502-33R1S

HySense® RS 100

The **HySense® RS 110** is an optical speed sensor that uses reflective mark detection. This method makes it possible to obtain particularly accurate and reliable measurements, since the measured results are not affected or distorted by the rotor's material or shape. Moreover, the available mounting base ensures that the sensor can be installed on metal surfaces easily and quickly.

How it works

This sensor works with a pulsing red light (LED) that is reflected by a special mark on the rotating part. A polarizing filter makes sure that only reflected light pulses will be evaluated and that disruptive reflections (e.g., unevenness on the surface, shiny metal parts, keyways, and high-contrast areas) will not be detected.

Typical applications:

- I Determining the hydraulic efficiency of pumps
- I Speed measurements on fans for hydraulic cooling units

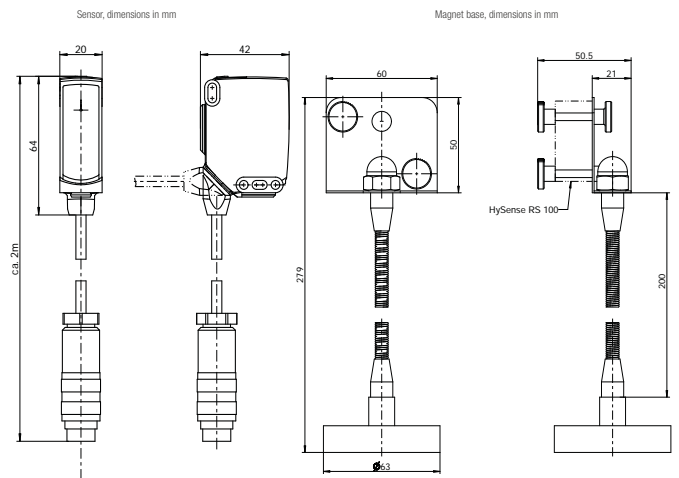
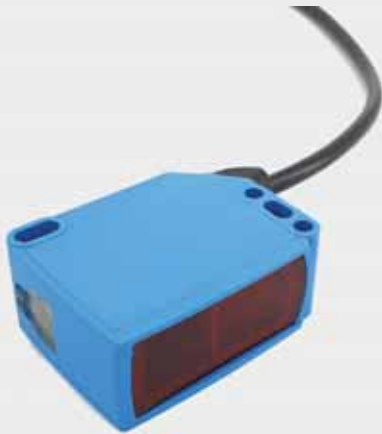

General characteristics

Sensor principle	Autocollimation
Light source	Power LED with visible red light
Response time	500 µs
Range	0 ... 500 mm (standard reflectors)
Pulsing frequency	500 Hz / 30000 min-1
Signal repetition rate	Max. 500 Hz
Electrical connector	M16 x 0.75, 5-pin
Body material	Glass fiber reinforced
Ambient temperature	-40 ... 60 °C

Model	Output signal	Weight	Part No.
HySense® RS 100	Frequency / ISDS	140 g	3130-08-01.01
Magnetic base	-	-	3130-03-03.00
Reflective film (50 pieces)	-	-	8840-02-01.01

HySense® RS 3xx

The **HySense® RS 3xx** is a high-precision frequency sensor that converts the motion of diamagnetic materials into pulses using the GMR effect. The use of this effect makes precise frequency measurements possible even with very small gears and low rotational speeds.



General characteristics	
Sensor principle	GMR effect
Frequency range	0.5 ... 1800 Hz
Measuring accuracy	±1 pulse
Electrical connector	M16 x 0.75, 5-pin / M16 x 0.75, 6-pin
Body material	Aluminum
Ambient temperature	-20 ... 85 °C
IP degree of protection	IP65 (DIN EN 60529)
Weight	60 g

Model	Output signal	H	Part No.
HySense® RS 300	Frequency, ISDS	104 mm	3107-00-S-49.00
HySense® RS 310	Frequency		3107-00-49.00

HySense® RS 5xx

HySense® RS 5xx is Hydrotechnik's revolutionary inductive sensor series, which detects the frequency of rotating components with extremely high accuracy and stability. These sensors contain a microcontroller with sufficient computing power, and are accordingly also referred to as "intelligent sensors." In turn, this sensor intelligence makes it possible to modify a signal on the basis of linearization tables in the sensor itself so that a compensated output signal can be output (RS 506, RS 510).

A heavy-duty and compact design makes easy and fast installation possible and means that these sensors can be used in harsh environments. This sensor series was developed specifically for Hydrotechnik turbine flow meters, but can also be used for a broad range of measuring tasks.



HySense® PO 180

The **HySense® PO 180** is a high-resolution draw-wire position sensor. Its compact and heavy-duty design makes it impervious to environmental conditions, which is why it is an ideal choice for use with cranes, hydraulic presses, and a broad range of equipment for which travel or position changes need to be measured.



General characteristics	
Sensor principle	Electromagnetic induction
Measuring range	1 ... 10000 Hz (RS 500 & RS 506) 1 ... 5000 Hz (RS 510)
Measuring accuracy	±1 pulse (RS 500) ±0.1% of full scale (RS 506 & RS 510)
Electrical connector	M16 x 0.75, 6-pin / M12, 4-pin*
Mechanical connection	M14 x 1
Body material	Aluminum
Ambient temperature	-25 ... 85 °C (RS 500 & RS 510) -20 ... 70 °C (RS 506)
IP degree of protection	IP67 (DIN EN 60529)

* More available upon request

Model	Output signal	Function	Electrical connector	H	Part No.
HySense® RS 500	Frequency	ISDS	M16 x 0.75, 6-pin	73 mm	3410-1600-A233F03
HySense® RS 500	Frequency	ISDS	M12, 4-pin	87 mm	3410-1600-A211F07
HySense® RS 506	CANopen	Smart sensor with ISDS	M12, 4-pin	113 mm	3410-1400-A213C11
HySense® RS 510	4 ... 20 mA	Smart sensor with ISDS	M16 x 0.75, 6-pin	106 mm	3410-1400-A233Z1S
HySense® RS 510	4 ... 20 mA	Smart sensor with ISDS	M12, 4-pin	113 mm	3410-1400-A211Z13

General characteristics

Sensor principle	Draw wire
Output signal	4 ... 20 mA
Nonlinearity	<±0.1% of full scale
Temperature coefficient	±0.01% / K
Electrical connector	8-pin connector DIN 45326
Housing / draw wire material	Aluminum and stainless steel / stainless steel
Ambient temperature	-20 ... 85 °C
IP degree of protection	IP65 (DIN EN 61076-2-106)

Measuring range	Max. extension force	Max. retraction force	A	Weight	Part No.
mm	N	N	mm	g	
0 ... 100	4.7	3	8	800	3183-13-03.37
0 ... 375	7.4	3.9	12.5		3183-13-05.37
0 ... 1000	5.3	2.9	8	1550	3183-13-02.37
0 ... 3000	6.2	3	10		3183-12-02.37

Measuring range of 0 ... 3000 mm

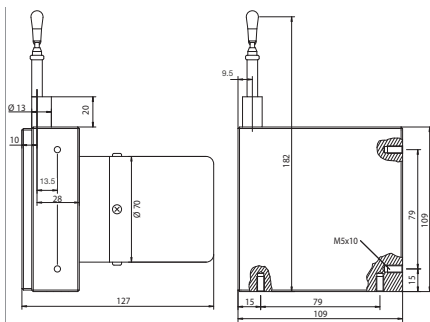

Dimensions in mm

Other measuring ranges

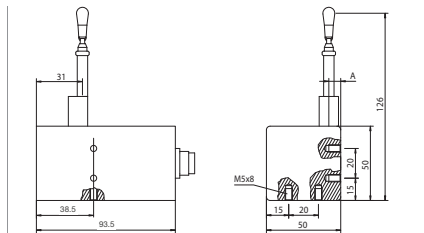

HySense® VB 110

The **HySense® VB 110** is a capacitive vibration sensor that was engineered specifically for low-lag data acquisition in difficult ambient conditions. The permanent magnets integrated into the base ensure that the sensor can be installed on metal surfaces easily and quickly.



General characteristics

Sensor principle	Capacitive acceleration sensor
Frequency range	1 ... 100 Hz
Measuring range	±50 G
Output signal	Frequency (square wave signal)
Nonlinearity	< ±2%
Measuring accuracy	< ±2%
Electrical connector	M16 x 0.75, 5-pin
Mechanical connection	Magnetic base
Body material	Plastic; resistant to fuels, oils, salts, and specific chemicals
Ambient temperature	-20 ... 85 °C
IP degree of protection	IP66 (sensor element)
Weight	547 g
Part No.	3183-71-01.00

HySense® SC 100

The **HySense® SC 100** is an intelligent, multi-functional transducer that not only converts frequencies to an analog 4 to 20 mA signal, but is also able to determine the phase relationship between two input frequencies and output it via a switching output. This makes it possible, for example, to detect and output the flow direction for a gear flow meter (two input frequencies).

This sensor intelligence makes internal sensor signal compensation and phase evaluation on the basis of stored linearization tables possible.

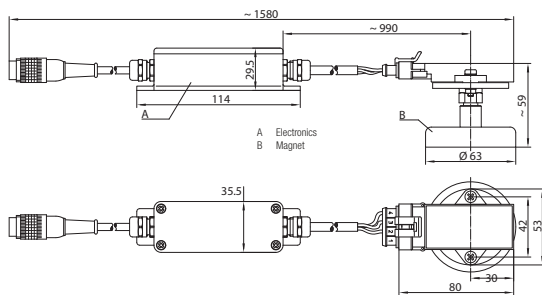

Dimensions in mm



General characteristics

Measured variable	Frequency (optionally two frequencies)
Measuring range	0 ... 5000 Hz
Output signal	4 ... 20 mA, ISDS (optional switching output Ub+)
Measuring accuracy	±0.1% of full scale
Electrical connector 1	M16 x 0.75, 6-pin
Electrical connector 2	M16 x 0.75, 6-pin
Body material	Aluminum
Ambient temperature	-25 ... 85 °C
IP degree of protection	IP67 (DIN EN 61076-2-106)
Weight	75 g
Part No.	3410-6600-3433D1V

* More available upon request

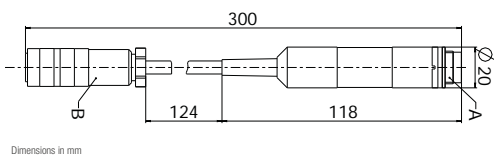

HySense®
The synonym of
uncompromising quality and
precision!

HySense® RS | PO | SC accessories

Cables compatible with HySense® RS | PO | SC

Compatible with HySense®	Measuring device connection	Length (m)	Part No.
(M16 6-pol.) RS 300, 310 RS 500, 510 SC 100	M16, 6-pin	5	8824-S1-05.00S
	M16, 6-pin (high-end)	5	8824-S1-05.00H
	Unterminated cable end	5	8824-S6-05.00S
RS 506	M12, 5-pin	5	8824-N3-05.00
	M12, 8-pin	5	8824-R7-05.00
	Unterminated cable end	5	8824-M8-05.00
(M12 4-pol.) RS 500, 510	M16, 6-pin	2.5	8824-V3-02.50S
	M12, 4-pin	2.5	8824-V2-02.50
	Unterminated cable end	2.5	8824-V1-02.50
PO 180	M16, 5-pin	2.5	8824-GA-02.50S

For additional lengths and versions, please refer to page 226

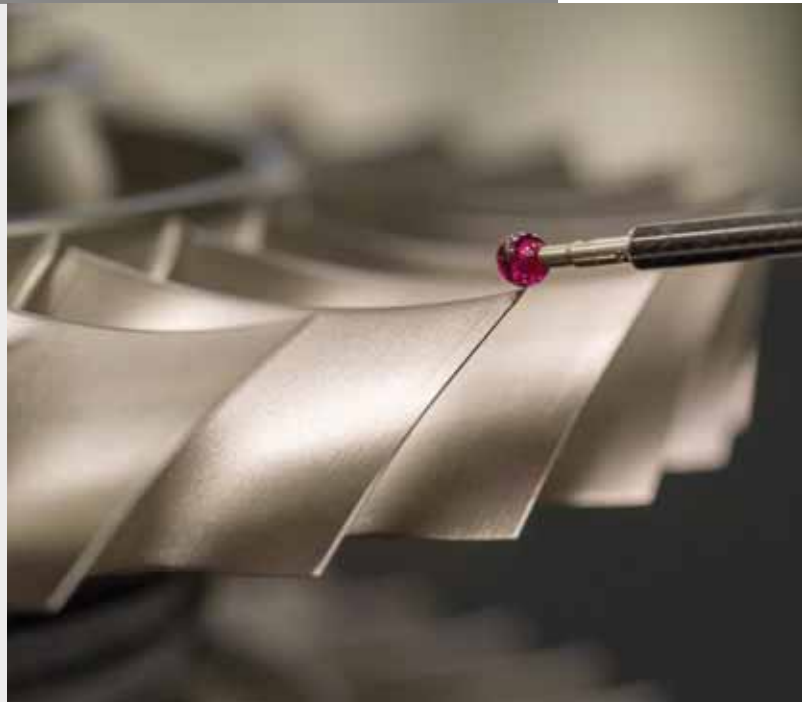

Hydrotechnik measuring systems: Continuity and innovation

Measuring systems



Trendsetting details and innovative solutions

As you well know, you need pressure, temperature, and volumetric flow rate measurements in order to monitor, control, and diagnose your pressurized systems.

Moreover, by keeping a record of your measurement data, you can obtain a basis for analyzing measured data.

With their product characteristics, Hydrotechnik handheld measuring devices are sure to provide you with the functions you need for your condition monitoring applications when used in combination with our professional software. Moreover, our measuring systems are able to record stationary and mobile sensor data with three to 42 channels. In addition, continuous and event-based measurements (i.e., the measurement starts only after a specific reading is reached or a specific event occurs) can be configured, and our measuring

systems feature the option of conveniently and safely transmitting measurements wirelessly in real time.

Hydrotechnik measuring systems are also designed to enable you to graphically prepare your measurements, generate measurement reports, and reproduce test and measuring specifications without any programming skills. One of the main characteristics is the devices' user friendliness and flexibility, which make it possible to work with virtually any industrial measurement variable. From the entry-level model to our mobile all-rounder, Hydrotechnik measuring devices are designed to be universally easy to use.

Measuring systems

Measuring systems



	MH2025	MH3020	MS4070	MS5070	MS8050
Channels	3	4	17	42	32/40
Analog					
Number	(2)	2	3 (4)	6 (8)	10
Signals	0 ... 20 mA, 4 ... 20 mA, 0 ... 10 V, 2 ... 10 V	0 ... 20 mA, 4 ... 20 mA	0 ... 20 mA, 4 ... 20 mA, 0 ... 10 V, 2 ... 10 V, 1 ... 5 V, 0.5 ... 4.5 V, ±10 V	0 ... 20 mA, 4 ... 20 mA, 0 ... 10 V, 2 ... 10 V, 1 ... 5 V, 0.5 ... 4.5 V, ±10 V	0 ... 20 mA, 4 ... 20 mA, 0 ... 10 V, ±10 V
Analog channels for V/I measurement	–	–	–	–	2
Signals	–	–	–	–	±2 ADC (one), ±48 ADC (one)
Analog outputs	–	–	–	–	2
Analog output signals	–	–	–	–	0 ... 20 mA (x1) -20 ... 20 mA (x1)
Frequency					
Number	(2)	1	1 (2)	(2)	4
Frequency signals	FRQ, ±FRQ, CNT, ±CNT	FRQ	FRQ, ±FRQ, CNT, ±CNT, ±CNT(40)	FRQ, ±FRQ, CNT, ±CNT, ±CNT(40)	FRQ, ±FRQ, CNT, ±CNT
Frequency range	1 ... 10 kHz	0.25 Hz ... 5 kHz	0.25 Hz ... 20 kHz	0.25 Hz ... 20 kHz	0.05 Hz ... 5 kHz
Configurable (*)					
Number	2	–	1	2	–
Calculated / CAN					
Number	1	1	10	32	6/14
CAN interface	–	–	1	2	1
Digital					
Digital inputs	–	–	1	1	4
Digital outputs	–	–	1	1	4
Memory					
Fastest recording rate	1 ms	1 ms	1 ms	0.1 ms	0.1 ms
Number of recordings	5	14	100	500	200
Number of readings per recording	120,000	1 Mio	2 Mio	6 Mio	6 Mio
Internal memory	2 MB	2 MB	4 GB	4 GB	2 GB
Sampling rate	1 ms, 10 ms, 100 ms, 1 s, 10 s	1 ms ... 16 h	1 ms ... 16 h	0.1 ms ... 16 h	0.1 ms ... 16 h
Recording duration	60 s ... 166 h	1 s ... 999 h	1 s ... 999 h	1 s ... 999 h	1 s ... 999 h
Triggers	–	1	4	4	2

Measuring systems



	MH2025	MH3020	MS4070	MS5070	MS8050
Sampling rate / Filter					
Fastest sensor sampling rate	1 kHz	1 kHz	1 kHz	10 kHz (all channels)	10 kHz (2 channels)
Fastest CAN sampling rate	–	–	1 kHz	1 kHz	0.1 kHz
Configurable filter	–	–	Digital FIR software filter	Digital FIR software filter	Software filter (arithmetic mean)
Display					
Display size	2.6"	2.1"	3.5"	5"	10.4"
Display type	Monochrome LCD display	Monochrome LCD display	TFT color display (QVGA)	TFT color display (QVGA)	TFT touch color display (VGA)
Graphic / color display	–	–	Yes	Yes	Yes
Max. channels shown	3	4	17	42	30
Min/Max	Yes	Yes	Yes	Yes	Yes
General					
Sensor detection	ISDS	ISDS	ISDS	ISDS	ISDS
Calculated measurement values	Differential, hydraulic power	Differential, hydraulic power, dx/dt, total	Differential, hydraulic power, definable formula, viscosity	Differential, hydraulic power, definable formula, viscosity	Addition, subtraction, multiplication, division, formula, hydraulic power (with formula)
Special applications	–	–	HYDRORun, HySense® QT 600, HySense® QL 326	HYDRORun, HySense® QT 600, HySense® QL 326	HYDRORun
Connectivity	–	–	MultiXtend Bluetooth, LAN	MultiXtend Bluetooth, LAN	MultiXtend Bluetooth, LAN
Oil condition	–	–	Patrick, HySense® CX 197, HySense® CL 100, HySense® CM 100, HySense® CW 100, HySense® CV 100	Patrick, HySense® CX 197, HySense® CL 100, HySense® CM 100, HySense® CW 100, HySense® CV 100	Patrick, HySense® CX 197, HySense® CL 100, HySense® CM 100, HySense® CW 100, HySense® CV 100
Expansions	MultiXtend UI, Split	MultiXtend UI, Split	MultiXtend A, f, Thermo, Split, Trigger	MultiXtend A, f, Thermo, Split, Trigger	MultiXtend A, f, Thermo, Split, Trigger
Degree of protection	IP40	IP40	IP40	IP40	IP40
Operating temperature	-10 ... 60 °C	0 ... 50 °C	-10 ... 50 °C	-10 ... 50 °C	0 °C ... 40 °C
Battery	NiMH	NiMH	Li-ion	Li-ion	–
Battery duration	> 10 h (two sensors)	> 16 h (three sensors)	> 10 h (five sensors)	> 8 h (eight sensors)	–
Battery charging time	< 12 h	< 14 h	< 3 h	< 2 h	–

MultiHandy 2025

Are you interested in using high-precision measurements for complex technical systems instead of the old analog measurements? Then make the switch to Hydrotechnik digital measuring technology and see how your measurements become more accurate and reliable than ever before!

- | Easy and fast: Connect, measure, document!
- | Flexible and versatile: Current, voltage, and frequency inputs for all industrial sensors.
- | Digital and powerful: Test probes can be immediately detected and analyzed.
- | Precise and enduring: Legally required documentation can be documented.
- | Ready to go: Fast data transmission and intuitive report generation.

Our **MultiHandy 2025** is available in a kit customized according to your needs and including two **HySense® PR 509** pressure sensors.



MultiHandy 2025	
Channels	3
Analog	
Number	(2)
Signals	0 ... 20 mA, 4 ... 20 mA, 0 ... 10 V, 2 ... 10 V
Frequency	
Number	(2)
Frequency signals	FRO, ±FRO, CNT, ±CNT
Frequency range	1 ... 10 kHz
Configurable (*)	
Number	2
Calculated / CAN	
Number	1
CAN interface	–
Memory	
Fastest recording rate	1 ms
Number of recordings	5
Number of readings per recording	120,000
Internal memory	2 MB
Sampling rate	1 ms, 10 ms, 100 ms, 1 s, 10 s
Recording duration	60 s ... 166 h
Sampling rate / Filter	
Fastest sensor sampling rate	1 kHz
Display	
Display size	2.6"
Display type	Monochrome LCD display
Max. channels shown	3
Min/Max	Yes
General	
Sensor detection	ISDS
Calculated measurement values	Differential, hydraulic power
Expansions	MultiXtend UI, Split
Degree of protection	IP40
Operating temperature	-10 ... 60 °C
Battery	NIMH
Battery duration	> 10 h (two sensors)
Battery charging time	< 12 h

MultiHandy 2025 pp kit

MultiHandy 2025 pp kit

Part Nos. for measuring kit versions

2025D-pp-15-15	2025D-pp-15-18	2025D-pp-18-18	2025D-pp-18-21
0 ... 400 bar, 0 ... 400 bar	0 ... 400 bar, 0 ... 600 bar	0 ... 600 bar, 0 ... 600 bar	0 ... 600 bar, 0 ... 60 bar

Included:

One MultiHandy 2025	One quick start guide
Two HySense® PR 509 pressure sensors, incl. cables	One shoulder strap kit
Two MINIMESS® 1620 direct adapters	One plastic case
One power adapter, incl. a micro USB cable	

Cables

Part No.	HySense®/ MultiXTend	xx.xx (length in meters)
8824-S1-xx.xxS*	PR, TE, OT, OG / UI, SPLIT	02.50 / 05.00 / 10.00
8824-S1-xx.xxH**	PR, TE, OT, OG / UI, SPLIT	
* S = Basic ** H = High-end	Degree of protection IP40 IP67	Extraction force 160 Nm 300 Nm

For additional information regarding cables, please refer to page 226



MultiPanel 2025

The display that can remember! The **MultiPanel 2025** is designed to cost-effectively consolidate both recording and displaying measurement data into a single unit. You can also use the integrated HYDROlink6 ADVANCED software key with a PC or laptop in order to visualize measured values on external monitors.

- I Simple and intuitive menu navigation despite small dimensions.
- I Backlit LCD display makes it easy to read measurement values.
- I Integrated HYDROlink6 ADVANCED software key (makes it possible to show measurement values on external monitors by using a PC or laptop)
- I Excellent connectivity: TTL switching contact and trigger inputs and outputs



MultiPanel 2025 kit	
Part No.	3160-00-80.00
Included:	
One MultiPanel 2025	One quick start guide
One terminal block	One mounting kit



MultiPanel 2025	
Channels	8
Analog	
Number	(2)
Signals	0 ... 20 mA, 4 ... 20 mA, 0 ... 10 V, 2 ... 10 V
Analog outputs	2
Analog output signals	0/4 ... 20 mA (x1), 0/2 ... 10 V (x1)
Frequency	
Number	(2)
Frequency signals	FREQ, ±FREQ, CNT, ±CNT
Frequency range	1 ... 10 kHz
Configurable (*)	
Number	2
Calculated / CAN	
Number	1
CAN interface	–
Digital	
Digital inputs	1
Digital outputs	1
Relays	
Relay output	1
Type	NC / NO / Changeover
Memory	
Fastest recording rate	1 ms
Number of recordings	5
Number of readings per recording	120,000
Internal memory	2 MB
Sampling rate	1 ms, 10 ms, 100 ms, 1 s, 10 s
Recording duration	60 s ... 166 h
Sampling rate / Filter	
Fastest sensor sampling rate	1 kHz
Display	
Display size	2.6"
Display type	Monochrome LCD display
Max. channels shown	3
Min/Max	Yes
General	
Sensor detection	ISDS
Calculated measurement values	Differential, hydraulic power

MultiHandy 3020

Are you looking for a measuring device that will enable you to monitor small to medium-sized systems in harsh environments?

We have the answer for you: The **MH3020!**

With three input channels, a heavy-duty aluminum housing, and a USB port, the **MultiHandy 3020** reliably and cost-effectively meets the essential requirements for the mobile acquisition of measurement data in harsh environments.

- I Versatile: Two analog channels and one frequency input channel
- I User-friendly: Large buttons, backlit display
- I Field-ready: Heavy-duty construction with aluminum housing
- I Large internal memory: For approx. 1 million readings per recording
- I High-capacity battery: For measuring the whole day without having to stop and charge



MultiHandy 3020		
Part No.	3160-00-72.00	
Included:		
One power adapter	One USB cable	
One CD with manual		
Cables		
Part No.	HySense®/ MultiXTend	xx.xx (length in meters)
8824-S1-xx.xxS*	PR, TE, QT, OG / UI, SPLIT	02.50 / 05.00 / 10.00
8824-S1-xx.xxH**	PR, TE, QT, OG / UI, SPLIT	
* S = Basic ** H = High-end	Degree of protection IP40 IP67	Extraction force 160 Nm 300 Nm

For additional information regarding cables, please refer to page 226



MultiHandy 3020	
Channels	4
Analog	
Number	2
Signals	0 ... 20 mA, 4 ... 20 mA
Frequency	
Number	1
Frequency signals	FRQ
Frequency range	0.25 Hz ... 5 kHz
Calculated / CAN	
Number	1
CAN interface	—
Memory	
Fastest recording rate	1 ms
Number of recordings	14
Number of readings per recording	1 Mio
Internal memory	2 MB
Sampling rate	1 ms ... 16 h
Recording duration	1 s ... 999 h
Triggers	1
Sampling rate / Filter	
Fastest sensor sampling rate	1 kHz
Display	
Display size	2.1"
Display type	Monochrome LCD display
Max. channels shown	4
Min/Max	Yes
General	
Sensor detection	ISDS
Calculated measurement values	Differential, hydraulic power, total
Expansions	MultiXTend UI, Split
Degree of protection	IP40
Operating temperature	0 ... 50 °C
Battery	NiMH
Battery duration	> 16 h (three sensors)
Battery charging time	< 14 h

MultiHandy 3020 pp kit



MultiHandy 3020 pTQ kit



MultiHandy 3020 pp kit

Part No.	3020A-pp-xx'-xx' ¹
-----------------	-------------------------------

¹ Measuring range code for the pressure sensors

Measuring range HySense® PR 100 pressure sensor	Code
0 ... 600 bar	18
0 ... 400 bar	15
0 ... 250 bar	17
0 ... 60 bar	21
-1 ... 6 bar	32

Included:	
One MultiHandy 3020	One power adapter
Two HySense® PR 100 pressure sensors	One USB cable
Two standard 5-m measuring cables	One plastic case
Two MINIMESS® 1620 direct adapters	

MultiHandy 3020 pTQ kit

Part No.	3020A-pTQ-xx'-yy' ²
-----------------	--------------------------------

¹ Measuring range code for the pressure sensors
² Measuring range code for the volumetric flow meter

Measuring range HySense® PR 100 pressure sensor	Code	Measuring range HySense® QT 500 flow meter	Code
0 ... 600 bar	18	600 l/min	72
0 ... 400 bar	15	300 l/min	71
0 ... 250 bar	17		
0 ... 60 bar	21		
-1 ... 6 bar	32		

Included:	
One MultiHandy 3020	One MINIMESS® 1620 direct adapter
One HySense® PR 100 pressure sensor	One power adapter
One HySense® TE 300 temperature sensor	One USB cable
One HySense® QT 500 flow meter	One HYDRCom6 ADVANCED software
Three standard 5-m measuring cables	One plastic case

MultiSystem 4070

Do you need measurements other than just pressure, temperature, and flow rate? Do you want to integrate data for multiple measurements or entire test sequences into your recording in a user-friendly and cost-effective manner? Do you want to know how your measurements are doing at any time and from anywhere?

The completely new **MultiSystem 4070** is the most efficient way to get started with the next level of measurement data recording!

- | New menu structure: ICON graphical user interface
- | Unbeatable connectivity: CAN bus, MultiXtend Bluetooth, LAN
- | Viscosity-compensated volumetric flow measurements: **HySense®** QT 600
- | Oil condition monitoring: **HySense®** CX 197, CV 100, CM 100, CL 100, CW 100, and Patrick
- | Maximum effectiveness: Lithium-ion battery technology; runtime ≥ 10 h
- | Fast charging function ≤ 3 h



MultiSystem 4070	
Part No.	3160-00-83.00
Included:	
One MultiSystem 4070	One USB Stick
One power adapter	One Software HYDROcom6 ADVANCED
1x USB cable	1x plastic case
The measuring systems MS4070 & MS5070 require a country-specific power supply cable for the power	
Part-No.	
EU power cord	8812-20-12-03
UK power cord	8812-20-12-04
USA/Japan power cord	8812-20-12-05
Australia power cord	8812-20-12-06

MultiControl 4070

Do you want to monitor your vehicles or systems during operation and record measurement data comprehensive and efficient? A harsh environment with dirt and moisture posed challenges to your previous measurement technology? The MultiControl 4070 offers the identical performance of the MultiSystem 4070 and convinces with a robust design and the IP65 protection class. Operation and configuration are very easy and comfortable with the integrated HYDROlink6 Advanced Software via your PC or laptop.



MultiControl 4070	
Part No.	3160-00-84.00
Included:	
One MultiControl 4070	One USB drive
One One power adapter	One Software HYDROlink6 ADVANCED
One USB cable	One plastic case
One ethernet cable	

Cables		
Part No.	HySense®/ MultiXtend	xx.xx (length in meters)
8824-S1-xxxxS*	PR, TE, QT, OG / UI, SPLIT	02.50 / 05.00 / 10.00
8824-S1-xxxxH**	PR, TE, QT, OG / UI, SPLIT	
8824-R7-xxxx	MultiXtend A, f, Thermo	02.50 / 05.00
8824-J2-xxxx	MultiXtend Bluetooth, LAN	
8824-F2-xxxx	MultiXtend Trigger	
8824-T6-xxxx	Patrick (power from device)	
8824-T2-xxxx	Patrick, ext. power (power adapter, Y splitter)	
Degree of protection IP40 IP67		Extraction force 160 Nm 300 Nm

*S = Basic
**H = High-end
For additional information regarding cables, please refer to page 226

MultiSystem 4070 / MultiControl 4070	
Channels	17
Analog	
Number	3(4) / 3(5)
Signals	0 ... 20 mA, 4 ... 20 mA, 0 ... 10 V, 2 ... 10 V, 1 ... 5 V, 0.5 ... 4.5 V, ± 10 V
Frequency	
Number	1(2) / (2)
Frequency signals	FRQ, \pm FRQ, CNT, \pm CNT, \pm CNT(40)
Frequency range	0.25 Hz ... 20 kHz
Configurable (*)	
Number	1 / 2
Signals	0 ... 20 mA, 4 ... 20 mA, 0 ... 10 V, 2 ... 10 V, 1 ... 5 V, 0.5 ... 4.5 V, ± 10 V, FRQ, \pm FRQ, CNT, \pm CNT, \pm CNT(40)
Frequency range	0.25 Hz ... 20 kHz
Calculated / CAN	
Number	10
CAN interface	1

MultiSystem 4070 / MultiControl 4070	
Digital	
Digital inputs	1
Digital outputs	1
Memory	
Fastest recording rate	1 ms
Number of recordings	100
Number of readings per recording	2 Mio
Internal memory	4 GB
Sampling rate	0.1 ms ... 16 h
Recording duration	1 s ... 999 h
Triggers	4
Sampling rate / Filter	
Fastest sensor sampling rate	1 kHz
Fastest CAN sampling rate	1 kHz
Configurable filter	Digital FIR software filter
Display (only MultiSystem 4070)	
Display size	3.5"
Display type	TFT color display (QVGA)
Graphic / color display	Yes
Max. channels shown	17
Min/Max	Yes
General	
Sensor detection	ISDS
Calculated measurement values	Differential, hydraulic power, definable formula, viscosity
Special applications	HYDRORun, HySense® QT 600, HySense® OL 326, oil condition analysis
Connectivity	MultiXtend Bluetooth, LAN / LAN-interface
Oil condition	Patrick, HySense® CX 197, HySense® CL 100, HySense® CM 100, HySense® CW 100, HySense® CV 100
Expansions	MultiXtend A, f, Thermo, UI, Split, Trigger
Degree of protection	IP40 / IP65
Operating temperature	-10 ... 50 °C
Battery	Li-Ion
Battery duration	> 10 h (five sensors)
Battery charging time	< 3 h

MultiSystem 4070 pp kit



MultiSystem 4070 ppTQ kit



MultiHandy 4070 pp kit

Part No.	4070-pp-xx ¹ -xx ¹
	¹ Measuring range code for the pressure sensors

Measuring range HySense® PR 100 pressure sensor	Code
0 ... 600 bar	18
0 ... 400 bar	15
0 ... 250 bar	17
0 ... 60 bar	21
-1 ... 6 bar	32

Included:

One MultiSystem 4070	One USB cable
Two HySense® PR 100 pressure sensors	One USB drive
Two standard 5-m measuring cables	One HYDRocom6 ADVANCED software
Two MINIMESS® 1620 direct adapters	One plastic case
One power adapter	

For notes regarding country-specific power cords, please refer to page 193

MultiSystem 4070 ppTQ kit

Part No.	4070-ppTQ-xx ¹ -xx ¹ -yy ²
	¹ Measuring range code for the pressure sensors ² Measuring range code for the volumetric flow meter

Measuring range HySense® PR 100 pressure sensor	Code	Measuring range HySense® QT 500 flow meter	Code
0 ... 600 bar	18	600 l/min	72
0 ... 400 bar	15	300 l/min	71
0 ... 250 bar	17		
0 ... 60 bar	21		
-1 ... 6 bar	32		

Included:

One MultiSystem 4070	One power adapter
Two HySense® PR 100 pressure sensors	One USB cable
One HySense® TE 300 temperature sensor	One USB drive
One HySense® QT 500 flow meter	One HYDRocom6 ADVANCED software
Four standard 5-m measuring cables	One plastic case
Two MINIMESS® 1620 direct adapters	

For notes regarding country-specific power cords, please refer to page 193

MultiSystem 5070

Do your tasks require maximum performance and capacity when it comes to mobile measurement data recording? Do you need to record and visualize a large number of measuring channels and highly complex test sequences precisely, including in danger zones?

The **MultiSystem 5070**, combined with professional software, is the perfect solution for recording and analyzing your readings regardless of the application. To put it simply, it is essential for every fluid specialist and a valuable tool for professional service technicians.

Wireless data transmission via MultiXtend Bluetooth minimizes the time spent in danger zones, and complex measuring tasks can be safely and efficiently recorded with predefined test sequences. Moreover, favorites can be freely chosen and screenshots can be saved, ensuring maximum ease of use.

- | Precise representation: 5" sunlight-readable color display
- | User friendly: ICON graphical user interface
- | Maximum memory: 500 recordings with up to 6 million readings per recording
- | Maximum sampling rate: Up to 10 kHz
- | 2 separate CAN interfaces: Incl. wake-up / trigger function
- | Viscosity-compensated volumetric flow measurements: **HySense®** QT 600
- | Oil condition monitoring: **HySense®** CV 100, CM 100, CL 100, CW 100, and Patrick



MultiSystem 5070	
Part No.	3160-00-82.00
Included:	
One MultiSystem 5070	One USB drive
One power adapter	One HYDROcom6 ADVANCED software
One USB cable	One plastic case
The MS4070 & MS5070 measuring systems require a country-specific power cord for the power adapter	
EU power cord	8812-20-12-03
UK power cord	8812-20-12-04
USA/Japan power cord	8812-20-12-05
Australia power cord	8812-20-12-06

Cables

Part No.	HySense®/ MultiXtend	xx.xx (length in meters)
8824-S1-xxxxS*	PR, TE, QT, OG / UI, SPLIT	02.50 / 05.00 / 10.00
8824-S1-xxxxH**	PR, TE, QT, OG / UI, SPLIT	
8824-R7-xxxx	MultiXtend A, f, Thermo	02.50 / 05.00
8824-J2-xxxx	MultiXtend Bluetooth, LAN	
8824-F2-xxxx	MultiXtend Trigger	
8824-T6-xxxx	Patrick (power from device)	
8824-T2-xxxx	Patrick, ext. power (power adapter, Y splitter)	
	Degree of protection IP40 IP67	Extraction force 180 Nm 300 Nm

* S = Basic
** H = High-end
For additional information regarding cables, please refer to page 226

MultiSystem 5070

Channels	42
Analog	
Number	6(8)
Signals	0 ... 20 mA, 4 ... 20 mA, 0 ... 10 V, 2 ... 10 V, 1 ... 5 V, 0.5 ... 4.5 V, ±10 V
Frequency	
Number	(2)
Frequency signals	FRQ, ±FRQ, CNT, ±CNT, ±CNT(40)
Frequency range	0.25 Hz ... 20 kHz
Configurable (*)	
Number	2
Signals	0 ... 20 mA, 4 ... 20 mA, 0 ... 10 V, 2 ... 10 V, 1 ... 5 V, 0.5 ... 4.5 V, ±10 V, FRQ, ±FRQ, CNT, ±CNT, ±CNT(40)
Frequency range	0.25 Hz ... 20 kHz
Calculated / CAN	
Number	32
CAN interface	2

MultiSystem 5070

Digital	
Digital inputs	1
Digital outputs	1
Memory	
Fastest recording rate	0.1 ms
Number of recordings	500
Number of readings per recording	6 Mio
Internal memory	4 GB
Sampling rate	0.1 ms ... 16 h
Recording duration	1 s ... 999 h
Triggers	4
Sampling rate / Filter	
Fastest sensor sampling rate	10 kHz (all channels)
Fastest CAN sampling rate	1 kHz
Configurable filter	Digital FIR software filter
Display	
Display size	5"
Display type	TFT color display (QVGA)
Graphic / color display	Yes
Max. channels shown	42
Min/Max	Yes
General	
Sensor detection	ISDS
Calculated measurement values	Differential, hydraulic power, definable formula, viscosity
Special applications	HYDRORun, HySense® OT 600, HySense® OL 326, oil condition analysis
Connectivity	MultiXtend Bluetooth, LAN
Oil condition	Patrick, HySense® CX 197, HySense® CL 100, HySense® CM 100, HySense® CW 100, HySense® CV 100
Expansions	MultiXtend A, f, Thermo, UI, Split, Trigger
Degree of protection	IP40
Operating temperature	-10 ... 50 °C
Battery	Li-Ion
Battery duration	> 8 h (eight sensors)
Battery charging time	< 2 h

MultiSystem 5070 pp kit



MultiSystem 5070 ppTQ kit



MultiHandy 5070 pp kit	
Part No.	5070-pp-xx¹-xx¹
	¹ Measuring range code for the pressure sensors

Measuring range	Code
HySense® PR 400 pressure sensor	
0 ... 600 bar	18
0 ... 400 bar	15
0 ... 250 bar	17
0 ... 60 bar	21

Included:	
One MultiSystem 5070	One USB cable
Two HySense® PR 400 pressure sensors	One USB drive
Two standard 5-m measuring cables	One HYDROcom6 ADVANCED software
Two MINIMESS® 1620 direct adapters	One plastic case
One power adapter	

For notes regarding country-specific power cords, please refer to page 199

MultiSystem 5070 ppTQ kit			
Part No.		5070-ppTQ-xx¹-xx¹-yy²	
		¹ Measuring range code for the pressure sensors	
		² Measuring range code for the volumetric flow meter	

Measuring range	Code	Measuring range	Code
HySense® PR 400 pressure sensor		HySense® QT 500 flow meter	
0 ... 600 bar	18	600 l/min	72
0 ... 400 bar	15	300 l/min	71
0 ... 250 bar	17		
0 ... 60 bar	21		

Included:			
One MultiSystem 5070	One power adapter		
Two HySense® PR 400 pressure sensors	One USB cable		
One HySense® TE 300 temperature sensor	One USB drive		
One HySense® QT 500 flow meter	One HYDROcom6 ADVANCED software		
Four standard 5-m measuring cables	One plastic case		
Two MINIMESS® 1620 direct adapters			

For notes regarding country-specific power cords, please refer to page 199

MultiSystem 8050

Do you need a large number of channels and the perfect proportion of input/output channels for your recording tasks? Are you interested in optimally visualizing and safely recording an extensive amount of readings for your stationary measuring task?

The **MultiSystem 8050** is the perfect measuring system for your stationary applications. With a total of 32 (optionally 40) channels and a large touch display, it is able to visualize a large number of readings in a clear and manageable manner, regardless of whether as numeric values or as a line chart.

- I Perfect for complex measurements: Up to 30 channels simultaneously on the TFT monitor
- I User-friendly and clearly laid out: Touchscreen monitor and logical menu structure
- I Live reading analysis: A large graphic display for perfect line charts
- I Universal versatility: Analog and digital inputs and outputs and a wide variety of interfaces



MultiSystem 8050		
Part No.	3160-00-65.00	
	3160-00-65.01	(14x Calculated / CAN)

Included:	
One MultiSystem 8050	One HYDRocom6 PROFESSIONAL software
One power adapter	One service connector
One USB cable	

Cables		
Part No.	HySense®/ MultiXtend	xx.xx (length in meters)
8824-S1-xx.xxS*	PR, TE, QT, OG / UI, SPLIT	02.50 / 05.00 / 10.00
8824-S1-xx.xxH**	PR, TE, QT, OG / UI, SPLIT	
8824-N1-xx.xx	MultiXtend A, f, Thermo	02.50 / 05.00
8824-TA-xx.xx	MultiXtend Bluetooth	
8824-F2-xx.xx	MultiXtend Trigger	
8824-T5-xx.xx	Patrick, ext. power (power adapter, Y splitter)	
* S = Basic ** H = High-end	Degree of protection IP40 IP67	Extraction force 160 Nm 320 Nm

For additional information regarding cables, please refer to page 226

MultiSystem 8050	
Channels	32(40)
Analog	
Number	10
Signals	0 ... 20 mA, 4 ... 20 mA, 0 ... 10 V, ± 10 V
Analog channels for VII measurement	2
Signals	± 2 ADC (one), ± 48 ADC (one)
Analog outputs	2
Analog output signals	0 ... 20 mA (x1) -20 ... 20 mA (x1)
Frequency	
Number	4
Frequency signals	FRQ, \pm FRQ, CNT, \pm CNT
Frequency range	0.05 Hz ... 5 kHz
Calculated / CAN	
Number	6(14)
CAN interface	1
Digital	
Digital inputs	4
Digital outputs	4
Memory	
Fastest recording rate	0.1 ms
Number of recordings	200
Number of readings per recording	6 Mio
Internal memory	2 GB
Sampling rate	0.1 ms ... 16 h
Recording duration	1 s ... 999 h
Triggers	2
Sampling rate / Filter	
Fastest sensor sampling rate	10 kHz (2 channels)
Fastest CAN sampling rate	0.1 kHz
Configurable filter	Software filter (arithmetic mean)
Display	
Display size	10.4"
Display type	TFT touch color display (VGA)
Graphic / color display	Yes
Max. channels shown	30
Min/Max	Yes

MultiSystem 8050	
General	
Sensor detection	ISDS
Calculated measurement values	Addition, subtraction, multiplication, division, definable formula, hydraulic power
Special applications	HYDROrun
Wireless	MultiXtend Bluetooth, LAN
Oil condition	Patrick, HySense® CX 197, HySense® CL 100, HySense® CM 100, HySense® CW 100, HySense® CV 100
Expansions	MultiXtend A, f, Thermo, UI, Split, Trigger
Degree of protection	IP40
Operating temperature	0 ... 40 °C

MultiControl 8050

The MultiControl 8050 is a version of the MultiSystem 8050 without a display, but packs the same amount of power and performance as the latter. Simply hook up the device to your PC or laptop via USB or LAN and use the integrated HYDROlink6 ADVANCED software key to configure it easily and conveniently.

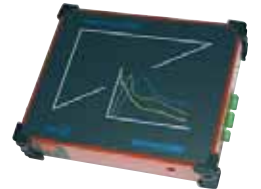

MultiControl 8050	
Part No.	3160-00-66.00
	3160-00-66.01 (14x Calculated / CAN)

Included:	
One MultiControl 8050	One HYDROcom6 PROFESSIONAL software
One power adapter	One HYDROlink6 ADVANCED software
One USB cable	One service connector

SEG 1060

Simply display your readings! Use the **SEG 1060** flush-mounting device for control panels in order to show your readings clearly. The small installation size makes it easy to integrate into systems, and the four buttons on the front panel, together with the logical menu structure, guarantee ease of use.

The large digital display can be comfortably read from a distance. Finally, the **SEG 1060** is optionally available with an analog and digital output.

- I Measuring device for flush-mounting in control panels: With configurable input for analog or frequency sensors
- I Optimum visualization: The large digital display is easy to read
- I Great flexibility: With optional outputs
- I Easy to use: Only four buttons and a logical menu structure



SEG 1060		
Part No.	3192-04-10.00	24 VDC
	3192-04-11.00	24 VDC, digital and analog output
	3192-04-20.00	230 VAC
	3192-04-21.00	230 VAC, digital and analog output

Included:	
One SEG 1060	One manual
One mounting kit	

SEG 1060	
Channels	1(3)
Analog	
Analog outputs (opt)	(1)
Analog output signals	0 ... 20 mA, 4 ... 20 mA
Configurable	
Number	1
Signals	0 ... 20 mA, 4 ... 20 mA, 0 ... 10 V, FRQ
Frequency range	1 ... 10 kHz
Digital	
Digital outputs (opt)	(1)
Relays	
Relay output (opt)	(1)
Type	NC / NO
Sampling rate / Filter	
Fastest sensor sampling rate	1 kHz
Display	
Display size	Seven-segment LED
Numbers	4
Max. channels shown	1
General	
Expansions	MX UI
Degree of protection	IP40
Operating temperature	-20 ... 50 °C

“Patrick” the particle counter

Do you want to significantly reduce machine downtimes due to failure or maintenance and schedule them in the most cost-effective manner possible?

That is where the “Patrick” particle counter comes in. This unit makes it possible to monitor contamination levels and fluid contamination trends with high precision, and changes in specific parameters can be used to draw conclusions regarding the need for maintenance and repairs. In other words, “Patrick” makes it possible to diagnose and monitor the oil quality in hydraulic systems.

The contamination class can be displayed in conformity with ISO4406:99 / SAE AS 4059 / NAS 1638 / GOST 17216.

- I Detect contamination in fluids
- I Minimize machine failures
- I Schedule downtimes in a cost-effective manner
- I Data transmission via CAN, USB (adapter), or RS-232



Patrick Optical particle counter	
Part No.	3160-00-76.00
Sensor principle	Light obscuration
Included:	
One Patrick	One quick start guide
Attachments	
Flow control valve max. 350 bar	2103-A0-02.00
Contamination classes	
Number	4
Type	ISO 4406:99 // SAE AS 4059 // NAS 1638 // GOST 17216
Measuring range (ISO 4406:99)	0 ... 24
Calibrated range (ISO 1171:2010)	10 ... 22
Measuring accuracy	±1
Fluids	
Type	Mineral oil (e.g., HLP) // Ester fluids (e.g., HEES) // Biodegradable fluids (e.g., HETG) // Diesel fuels
Temperature	-20 ... 85 °C
System conditions	
Flow rate	50 ... 400 ml/min
Static operating pressure	600 bar / 8700 psi
Dynamic operating pressure	420 bar / 6100 psi
Connection	
Fluid connection	Two MINIMESS® 1620 units
Interface	RS-232, CANOpen, J1939
Analog outputs	1
Analog output signals	4 ... 20 mA
Memory	
Data memory	3072 measurements
Display	
Display size	2.2"
Display type	Monochrome LCD display
Max. classes shown	4
General	
Degree of protection	IP65
Operating temperature	-20 ... 85 °C at 0 ... 95% rel. humidity

Patrick in the Box

Patrick in the Box is our offering for anyone looking for a portable particle monitoring solution!

The device can be used to immediately analyze samples from oil tanks and sample bottles in regard to contamination, ensuring that you can prevent hydraulic system failures and schedule servicing work as appropriate. This proactive maintenance approach is ideal for locations with multiple storage tanks / systems and makes this analysis device the ultimate solution for measuring and diagnostic work.



Patrick in the Box	
Part No.	3402-CP20-D200-000
Sensor principle	Light obscuration
Included:	
One Patrick in the Box	One DN4 hose, incl. suction filter
One power adapter	One manual
One DN4 hose, incl. suction filter	
Attachments	
Pressure reducing valve max. 350 bar	5117-06-20.00

Patrick in the Box	
Contamination classes	
Number	4
Type	ISO 4406:99
	SAE AS 4059
	NAS 1638
	GOST 17216
Measuring range (ISO 4406:99)	0 ... 24
Calibrated range (ISO 1171:2010)	10 ... 22
Measuring accuracy	±1
Fluids	
Type	Mineral oil (e.g., HLP)
	Ester fluids (e.g., HEES)
	Biodegradable fluids (e.g., HETG)
	Diesel fuels
Temperature	-20 ... 85 °C
Fluid sampling	
Internal pump type	Gear pump
Max. operating pressure	2.5 bar / 36 psi
Operating pressure (optional)	350 bar / 5075 psi
Sampling variants	Tank samples
	Bottle samples (min. 1000 ml)
	Pressure line (optional)
Connection	
Fluid connection	Two MINIMESS® 1604 units
Interface	RS-232, CANOpen, J1939
Analog outputs	1
Analog output signals	4 ... 20 mA
Display	
Display size	2.2"
Display type	Monochrome LCD display
Max. classes shown	4
General	
Degree of protection (closed)	IP67
Degree of protection (open)	IP54
Operating temperature	0 ... 50 °C at 0 ... 95% rel. humidity
Battery duration	> 3 h
Battery charging time	< 5 h

HYDROcom6

In addition to professional measuring equipment, comprehensive measuring tasks require powerful software for processing recorded data. And HYDROcom6 Base, which is available for free, is designed to provide you with a large part of the functionalities you need to do just that.

Meanwhile, HYDROcom6 Advanced/Professional can be used not only to visualize real-time readings, but also download, visualize, analyze, process, and present existing measurement data. And to generate your own measurement reports configured according to your specific needs, of course.

- | Fast data transfers: Transfer, import, and export data
- | Fast data processing: Evaluate, analyze, and process data
- | Present measurement results: Charts, tables, bar charts
- | Digital documentation: Test reports, measurement reports, QA reports

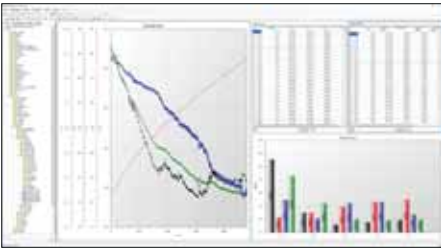

HYDROlink6

Sometimes you just need to be elsewhere! That is why Hydrolink6 makes it possible to completely configure your measuring systems with your PC or laptop regardless of whether you are on-site or on the go.

Take advantage of the highly effective remote access setup option for all measuring device/ channel / memory parameters and implement whole CANopen databases in order to make your work even more efficient.

Create highly complex test sequences for desktop and measuring system applications with the help of the new HYDROlink6 Professional.

Use a single click to generate personalized measurement reports, or use the simple real-time visualization / measurement function and the broad selection of associated layout options.

- | Efficient measuring device / channel / memory configuration
- | Full control of all functions via remote measuring system control
- | Implement CANopen databases
- | Easily generate complex test sequences (HL6 PRO)
- | Real-time visualization, incl. a wide selection of layout options



HYDROcom6			
	---	BASE	(Available for download free of charge at www.hydrotechnik.com)
Part No.	8874-19-01.05	ADVANCED	One license
	8874-19-01.06	PROFESSIONAL	One license
	8874-19-02.00	Upgrade from ADVANCED to PROFESSIONAL	One license
	8874-19-03.03	ADVANCED	15 licenses
	8874-19-03.01	PROFESSIONAL	15 licenses
Included:			
	HYDROcom6		One serial number key

HYDROlink6			
	---	BASE	(Available for download free of charge at www.hydrotechnik.com)
Part No.	8874-19-10.01	ADVANCED	One license
	8874-19-11.01	PROFESSIONAL	One license
Included:			
	HYDROlink6		One serial number key

HYDRORun6

Do you want to reliably visualize highly complex test sequences? Are you interested in minimizing measurement errors with predefined test plans?

If so, you can use HYDRORun or HYDRORun lite to visualize test sequences (generated with HYDROLink6 Professional) in a user-friendly manner. Depending on the software version, you can get a license for your existing measuring system e.g. MS4070/MS5070 or a desktop version.

- | Reliably visualize complex test sequences
- | Minimize errors with predefined test plans
- | Available as measuring system and desktop version.



HYDRORcenter

Stay up to date at all times! Manuals, technical data sheets, software, and firmware updates –

HYDRORcenter is there to make sure that you are always using the latest Hydrotechnik software and firmware versions. This way, your Hydrotechnik products can be updated quickly, reliably, and easily.

- | Keeps Hydrotechnik measuring systems and software products up to date at all times
- | Actively reminds you of software and firmware updates
- | Eliminates the need to spend time searching for updates
- | Provides the right product documentation directly



HYDRORun			
Part No.	8874-19-11.04	HYDRORun	One license
	8874-19-11.05	HYDRORun lite	One license
Included:			
	HYDRORun / lite		One serial number key

HYDRORcenter	
Part No.	– (Available for download free of charge at www.hydrotechnik.com)

MultiXtend

Measuring systems

Do more with your measuring system! With the MultiXtend product family, you can expand your measuring system or add additional functions to it. These additional devices can, for example, provide additional inputs for sensors with an analog or frequency input signal, measure electrical variables, be used to connect thermocouples, or connect to your existing network via LAN or wirelessly via Bluetooth.

MultiXtend Bluetooth

Not interested in staying in danger zones any longer than you have to? Or in transporting, connecting, and possibly damaging unnecessary cables?

Then the MultiXtend Bluetooth module, which makes it possible to take advantage of all the benefits of wireless data transmission, is the perfect device for your needs. Reduce costs by using fewer expensive measuring cables. Make use of reliable data transfers at distances of up to 300 m with the paired transmitter / receiver unit. Safely record readings (for rotating machines, for example) outside of danger zones.



MultiXtend LAN

Do you want to be able to access your measuring system from anywhere in the world? How about editing parameters and starting measurements remotely?

You can do so by quickly, easily, and affordably expanding your existing measuring system with the MultiXtend LAN. With this expansion, you can connect your MultiSystem to an existing network (TCP/IP). Take advantage of network-based reading acquisition, incl. measuring device / measuring channel setup options via HYDROlink6 ADVANCED.



MultiXtend Bluetooth	
Part No.	316A-00-10.00
Included:	
MultiXtend Bluetooth module	J2 connecting cable (MX BT – measuring system)
USB Bluetooth receiver	

MultiXtend LAN	
Part No.	316A-00-12.00
Included:	
MultiXtend LAN module	

MultiXtend A / f / Thermo

Does your measuring task go beyond what your existing measuring equipment can handle? No problem! With the devices in the MultiXtend A, f, and Thermo series, you can connect additional sensors to a MultiSystem. The sensor signals are digitized and transmitted to the measuring device through the CAN bus. And while MultiXtend channel expansions A and f each provide four M16 inputs for analog/frequency sensors and can be used with input ranges of 0 ... 20 mA or 4 ... 20 mA, MultiXtend channel expansion Thermo makes it possible to connect type J or K thermocouples.



MultiXtend UI

Are you missing the right tool for integrating current or voltage measurements into your system? In that case, you can use the MultiXtend UI to measure current or voltage at an analog measuring input (0 ... 20 mA). In addition to the galvanic isolation of the measuring inputs, the unit comes with the option of manually activating a PWM filter.

Available in two versions:

- I. MultiXtend UI ± 30 VDC / ± 2 ADC
- II. MultiXtend UI ± 60 VDC / ± 4 ADC



MultiXtend A, f, Thermo		
Part No.	A	3160-00-00.72AB
	f	3160-00-00.77
	Thermo type J	3160-00-00.73JB
	Thermo type K	3160-00-00.73KB
Included:		
MultiXtend (A/ f/ Thermo) module		

MultiXtend UI		
Part No.	I.	316A-00-00.20
	II.	316A-00-00.30
Included:		
MultiXtend UI module		

MultiXtend Split

Do you want to provide a single analog sensor signal to two receivers? We have the solution for you! The MultiXtend Split is a galvanically isolated, passive, feedback-free signal splitter that can be used to connect a single analog sensors to two receivers at the same time. This means, for example, that you can connect a permanently installed pressure sensor to a controller while also using that signal for diagnostic purposes.



MultiXtend Trigger

Are you on the lookout for a solution for storing readings on multiple measuring systems simultaneously? The MultiXtend Trigger matches this description, and can be used to send a trigger signal to a maximum of three measuring systems. A storage operation trigger will then be, for example, sent by a MultiSystem 5070 to a maximum of three additional measuring systems at the same time. This makes it possible to carry out simultaneous storage operations on up to 96 channels so that the stored information can then be automatically grouped together on a PC with HYDROcom6 or with the use of HYDROlink6.



MultiXtend Split

Part No.	316A-00-00.40
-----------------	---------------

Included:



MultiXtend Split module

MultiXtend Trigger













Part No.	316A-00-00.50
-----------------	---------------

Included:

MultiXtend Trigger module

Cables						
	Male connector	Female connector	Part No.	Description		
Sensor (A output)	M12, 4-pin		M12, 4-pin		8824-V2-xxxx	
	M16, 6-pin		M12, 4-pin		8824-V3-xxxxS	
	Unterminated cable end		M12, 4-pin		8824-V1-xxxx	
CANopen	M12, 5-pin		M12, 5-pin		8824-N3-xxxx	
	M12, 5-pin		M12, 8-pin		8824-J0-xxxx	
	M12, 5-pin		Unterminated cable end		8824-M7-xxxx	
	Unterminated cable end		M12, 5-pin		8824-M8-xxxx	
	M12, 8-pin		M12, 8-pin		8824-T6-xxxx	
	M12, 8-pin		Unterminated cable end		8824-R9-xxxx	
	Unterminated cable end		M12, 8-pin		8824-T1-xxxx	
	M12, 8-pin				8824-T2-xxxx	
	M12, 8-pin				8824-T2-xxxx	
	M12, 8-pin		M12, 5-pin		8824-R7-xxxx	
	M12, 8-pin		D-sub, 9-pin		8824-T7-xxxx	
	D-sub, 9-pin		M12, 5-pin		8824-N1-xxxx	
	M12, 8-pin D-sub, 9-pin	 			8824-T5-xxxx	
	M12, 8-pin		USB A		8824-T4-02.00	
	Product-specific	M12, 8-pin		M12, 8-pin (three)		8824-TB-00.00
M12, 5-pin			M12, 5-pin (three)		8824-IO-00.00	OL326
M16, 5-pin 2x			M16, 8-pin		8824-D6-xxxx	TP180
Unterminated cable end			AMP DIN 72585, 3-pin		8824-K8-xxxxS	TE380

xx.xx (length in meters) 02.50 / 05.00

Cables						
	Male connector	Female connector	Part No.	Description		
Standard (basic)	M16, 6-pin		M16, 6-pin		8824-S1-xxxxS	
	M16, 6-pin		M16, 6-pin		8824-S3-xxxxS	Extension cable
	Unterminated cable end		M16, 6-pin		8824-S6-xxxxS	
Standard (high-end)	M16, 6-pin		M16, 6-pin		8824-S1-xxxxH	
	M16, 6-pin		M16, 6-pin		8824-S3-xxxxH	Extension cable
	Unterminated cable end		M16, 6-pin		8824-S6-xxxxH	
Triggers	Digital input/output				8824-F2-00.50	
Ethernet	M12 8p X-Coded male	M12 RJ45 VBL802			8824-V7-02.00	MultiControl 4070
Data cable	USB A / B				8824-F4-02.00	
	USB A / Micro				8824-R4-02.00	
	USB A / Micro (bayonet)				8812-20-09.01	MultiHandy 2025
	USB A / C				8824-V6-02.00	MultiControl 4070

xx.xx (length in meters) 02.50 / 05.00 / 10.00

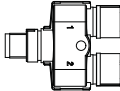
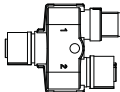
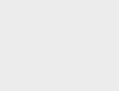
Y splitters				
M12 x 1		Description	Part No.	
8-pin		One male connector to	One female connector	8808-50-01.02
			One female connector	
5-pin		One female connector to	One male connector	8808-50-01.01
			One female connector	
8-pin		One female connector to	One male connector	8808-50-01.03
			One female connector	

Measuring system shock protection

We are happy to introduce you to our MS4070 / MS5070 shock protectors, which are designed to make systems even easier to use under adverse conditions.

This convenient accessory, which is made of rugged NBR, improves grip and provides shock absorption protection for your MS4070 / MS5070.



Part No.	
MultiSystem 5070	8854-30-03.30
MultiSystem 4070	8854-40-01.13

Accessories

Note	Part No.	
Power adapters		
MultiHandy 2025	8812-20-09.00	
MultiHandy 3020	8812-20-11.00	
MultiSystem 4070/5070	8812-20-11.00	
MultiSystem / MultiControl 8050	8812-02-00.03	
8-pin female connector (e.g., Patrick)	8812-00-00.36	
5-pin female connector (e.g., CAN, MultiXtend A/I/T/Thermo)	8812-00-00.34	
Country specific power cords		
MS4070/MS5070		
EU	8812-20-12.03	
UK	8812-20-12.04	
USA / Japan	8812-20-12.05	
Australia	8812-20-12.06	
Spare batteries		
MultiHandy 2025	AK-012120	
MultiHandy 3020	8873-08-02.00	
MultiControl 4070	8873-09-01.00	
MultiSystem 4070/5070	8873-09-01.00	
Cases		
MultiHandy 2025	3160-00-78.01	
MultiHandy 3020	3160-00-72.02	
MultiControl / MultiSystem 4070	8859-02-10.02	
MultiSystem 5070	8859-02-10.01	
Diverse		
Soiling protector	M16 measuring channel inputs	8822-06-03.15
Top hat DIN rail	MultiHandy 2025 / MultiSystem 4070/5070	8854-00-00.02
Car USB Adapter		8812-09-06.00
Car connection cable	MultiHandy 3020 / MultiSystem 4070/5070	8824-64-05.00
Car connection cable	Patrick	8824-T8-05.00



Service and calibration

Service and calibration

In order for readings to be accurate and reliable and yield solid analyses, measuring devices and sensors need to be precisely adjusted and calibrated.

For us at Hydrotechnik, our customer relationships do not simply end when we sell a product. Instead, we offer professional, reliable, and high-quality maintenance, repair, and calibration services designed to help you maintain your product's value. These services are not just limited to Hydrotechnik products, but can also cover all other competing products.

Maintenance

With regular high-quality maintenance, you can rest assured knowing that your sensors and measuring devices are working perfectly and are delivering meaningful measurement results. We are experts at checking sensors and measuring devices as quickly as possible so as to minimize downtimes.

Repairs

Uncompromising quality is not just an empty slogan for Hydrotechnik, but rather something that defines everything we do. All our operations consistently conform to all the applicable quality standards, and this conformity is documented and backed up by our ISO 9001 certification, which we have had since November 1996. In the unlikely event that your equipment experiences a problem, however, we will repair your sensor or device reliably, quickly, and cost-effectively.

Calibration

Since 1986, Hydrotechnik has operated a calibration laboratory accredited by DAkkS. In 2019, this accreditation was successfully updated to the new DIN EN ISO/IEC 17025:2018 standard.

We have over 30 years of calibration experience with pressure, fluid flow rates, temperature, and electrical parameters, and our test stands conform to traceable standards and meet all the requirements for an accredited calibration entity. Calibrations are carried out in conformity with all applicable guidelines and documented with internationally accepted DAkkS calibration certificates.

It is important to note that calibrating sensors, measuring devices, and measuring chains on a regular basis is essential and a prerequisite for accurate and reliable measurement results.

Measured variables and functionalities at a glance

Fluid flow rates

The Hydrotechnik calibration laboratory has three different state-of-the-art flow test stands for factory and DAkkS calibrations. A wide variety of mineral oils, plus the ability to keep them at constant temperatures, makes it possible to adjust viscosities as required with high precision.

Flow test stand I

- | Measuring range: 0.005 ... 40 L/min
- | Adjustable viscosity range: 1.2 ... 178 mm²/s
- | DAkkS and factory calibration

Flow test stand II

- | Measuring range: 2 ... 1000 L/min
- | Adjustable viscosity range: 21 ... 46 mm²/s
- | Factory calibration

Flow test stand III

- | Measuring range: 0.2 ... 600 L/min
- | Adjustable viscosity range: 1.2 ... 280 mm²/s
- | DAkkS and factory calibration

Pressure

We have two different high-precision dead weight testers for factory and DAkkS calibration available for pressure calibration. All calibration methods used are accredited in conformity with DIN EN ISO IEC 17025:2018 and adhere to guideline DKD 6-1.

Vacuum and overpressure:

- | Measuring range: -1 ... 7 bar
- | Pressurizing fluid: Gas
- | DAkkS and factory calibration

Overpressure:

- | Measuring range: 3 ... 1200 bar
- | Pressurizing fluid: Oil
- | DAkkS and factory calibration

Temperature

We have various temperature calibration baths with special temperature calibration oils available for temperature calibration. These calibrations are carried out with comparison measurements using traceable standards.

- | Temperature range: -50 ... 250 °C
- | Temperature calibration fluids: Silicone oils and water
- | Factory calibration

Electrical variables

We have a variety of calibration devices available for calibrating Hydrotechnik measuring devices.

Typical variables:

- | | |
|----------------|----------------------|
| Current (A) | Factory calibration |
| Voltage (V) | Loaners upon request |
| Frequency (Hz) | |

Viscosity and density

The Hydrotechnik calibration laboratory has a falling ball viscometer and the corresponding density determination balance for determining the viscosity and density of liquids.

Measured variables

- | Dynamic viscosity (mPa*s)
- | Density (g/cm³)

Additional services

Our decades of experience, combined with our professional measuring equipment, enable us to cover a broad range of specific measuring tasks. Upon request, we will be glad to take care of specific calibrations and measurements, such as determining the performance of one-way restrictors (measuring the pressure differential vs. flow).

Certifications and accreditations

- | Hydrotechnik GmbH in conformity with DIN EN ISO 9001:2015
- | Accredited calibration laboratory in conformity with DIN EN ISO/IEC 17025:2018
- | Accredited methods for fluid pressure and flow



A member of **DKD**



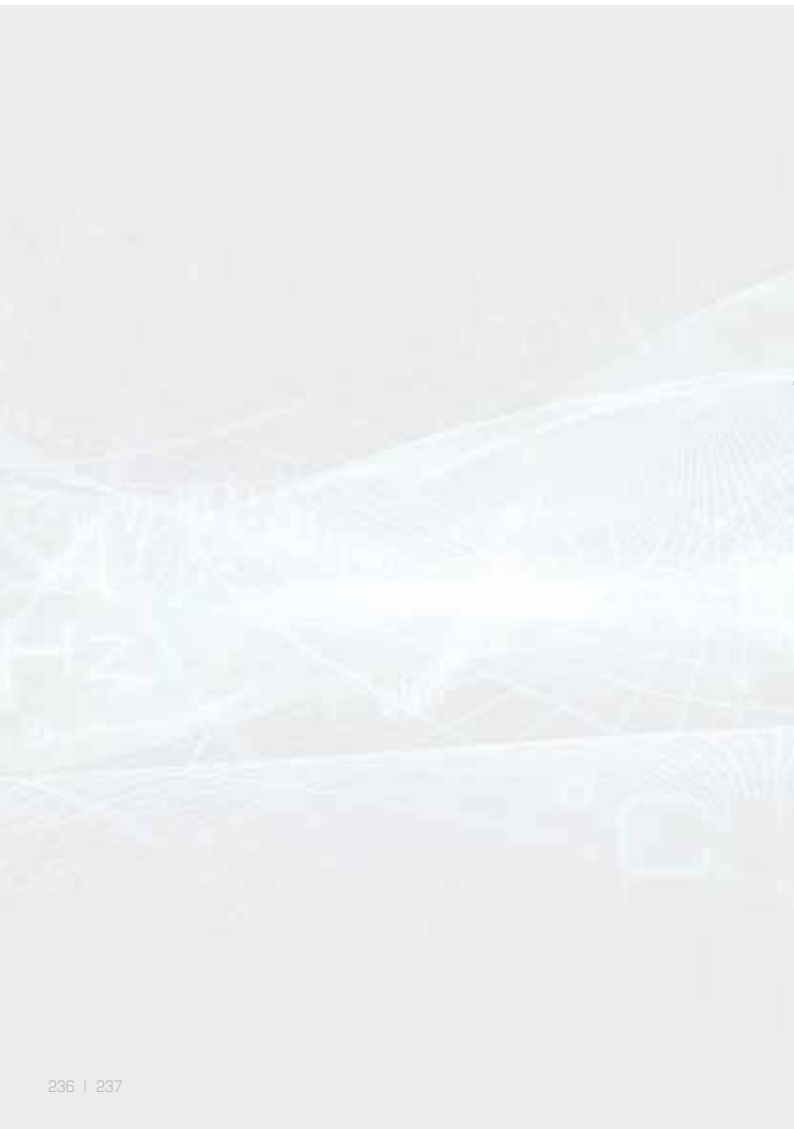

Disclaimer

The information in this catalog has been checked carefully. However, it is still possible for there to be misprints and other errors. Because of this, we assume no liability for the correctness of the information herein. Said information does not represent guaranteed product properties or characteristics, and the product descriptions in our quotations are the only authoritative descriptions within this context. We reserve the right to make changes in the course of further technical development. All previous catalogs are hereby null and void. The specifications in this catalog must be considered as non-binding information and can only be used for design purposes to a limited extent. If necessary, please request our technical data sheets and design aids. Since you are responsible for the use of the products supplied by us, you must, without fail, check to ensure that the products are suitable for your intended application. All deliveries will be made exclusively in accordance with our terms of delivery and payment, which are available in the "Legal notice" section of our website: www.hydrotechnik.com.

PLEASE
TURN OVER

