

# W22

## Three-Phase Electric Motor

Technical Catalogue  
European Market

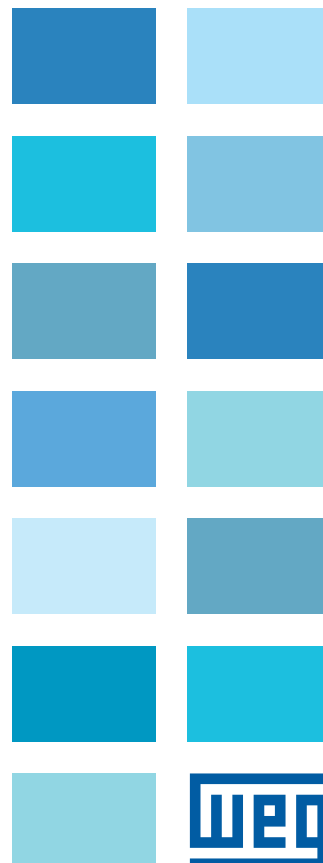

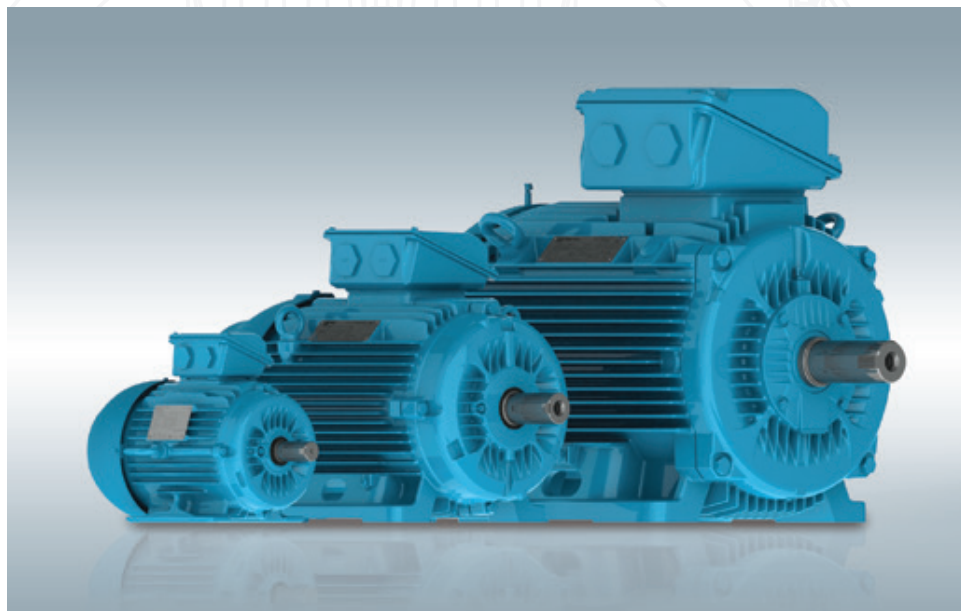

### W22 Line - High Efficiency Motors

The increasing demand for electrical energy to sustain global development requires consistent heavy investments in power supply generation. However, in addition to complex medium and long term planning, these investments rely on natural resources, which are becoming depleted due to constant pressures upon the environment. The best strategy, therefore, to maintain energy supply in the short term is to avoid wastage and increase energy efficiency. Electric motors play a major role in this strategy, since around 40% of global energy demand is estimated to be related to electric motor applications. Consequently, any initiatives to increase energy efficiency, by using high efficiency electric motors and frequency inverters, are to be welcomed, as they can make a real contribution to reductions in global energy demand.

At the same time as efficiency initiatives make an impact in traditional market sectors, the application of new technologies in emerging sectors is resulting in profound changes in the way that electric motors are applied and controlled. By integrating these changes together with the demands for increased energy efficiency, WEG has taken up the challenge and produced a new design of high efficiency motor, one that exceeds the performance of the previous WEG's W21 motor line, which is recognised worldwide for its quality, reliability and efficiency.

Using the latest generation of computerised tools, such as structural analysis software (finite element analysis) and computer fluid dynamics, as well as electrical design optimization software, an innovative - next generation - product has been developed: the W22 motor.

Several key objectives have been achieved in the design of the W22 motor:

- Reduction of noise and vibration levels;
- Increased energy efficiency and reduced thermal footprint;
- Easy maintenance;
- Compatibility with present & future generations of frequency inverters;
- Flexible and modular design.



Frame 63 to 132

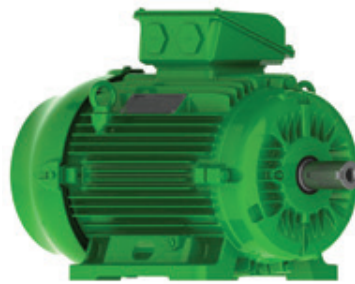

Frame 160 to 200



Frame 225 to 355

### Sustainability and Carbon Emission Reduction Through Super Premium Efficiency Motors

The Super Premium Efficiency (IE4) level established in IEC 60034-30-1: 2014 is considered the highest efficiency class which a squirrel cage induction motor can achieve whilst remaining economically viable. It is also the optimum solution to increase the efficiency of an existing application through direct replacement. So, why have Super Premium Efficiency motors not become the Industry standard?

It may be argued that super premium efficiency motors are also super premium in price when comparing against standard efficiency (IE1), high efficiency (IE2) and premium efficiency (IE3) motors.

Whilst this is not strictly untrue, it should be appreciated when considering their lifetime that the cost of acquisition of an induction motor typically represents only 2% of the total cost of ownership. In contrast, the associated energy savings provided by Super Premium

and Premium efficiency motors far outweigh this additional investment in purchase price.

The reduction in CO<sub>2</sub> emissions is one of the direct consequences, and therefore benefits, of increasing efficiency in industry. Using IE4 rated motors today will show that a company is serious about saving energy, reducing carbon and saving money.

Visit our website at [www.weg.net](http://www.weg.net) to check the potential energy savings, CO<sub>2</sub> emissions reduction and return on investment with W22 Premium and Super Premium motors.

The W22 Super Premium Efficiency line from WEG is the most complete range of IE4 motors available to Industry today, designed to offer not only a significant reduction in energy consumption, but improved noise and vibration levels, higher reliability, easier maintenance and lower overall total cost of ownership.

...we call it **WEGnology**

## Minimum Energy Performance Standards - Europe

Increasingly, the World seeks a path of sustainability and new ways to reduce energy consumption.

A significant percentage of the electrical energy utilized in facilities around the World is consumed by electric motors. Consequently, Governments around the World are implementing Energy Efficiency Programs in order to enforce the use of high efficiency motors.

Up until 2009, Europe did not have any specific regulations relating to the energy efficiency levels of electric motors. There existed only a voluntary agreement between Manufacturers from 1998 that determined the efficiency bands EFF1, EFF2 and EFF3.

However, in July 2009 Commission Regulation 640/2009 (implementing EuP Directive 2005/32/EC of July 2005) was adopted, which determined the ecodesign requirements relating to the scope, implementation dates and efficiency levels for electric motors and their use with variable speed drives.

Also referred to as EU MEPS (European Minimum Energy Performance Standards), the efficiency levels for electric motors are determined in two IEC standards: IEC/EN 60034-30-1, which details the efficiency classes in the form of 'IE' codes, and IEC/EN 60034-2-1 which defines the methods to be used to measure the efficiency.

The EU Regulation is mandatory within the European Economic Area, EEA (EU countries plus Norway, Iceland and Liechtenstein), from 16th of June 2011.

EU MEPS does not apply outside Europe. Manufacturers can continue to supply IE1 non-CE marked motors to customers located in Europe for further shipment to non-European markets, but these must of course respect any applicable energy efficiency legislation for the destination Country of use.

A new version of the EuP Directive (2009/125/EC) became effective on 21st October 2009 to expand the ecodesign requirements for Energy Related Products, whilst January 2014 saw the adoption of the Commission Regulation 4/2014 (amending the scope of 640/2009) which came into force with effect from 27th July 2014.

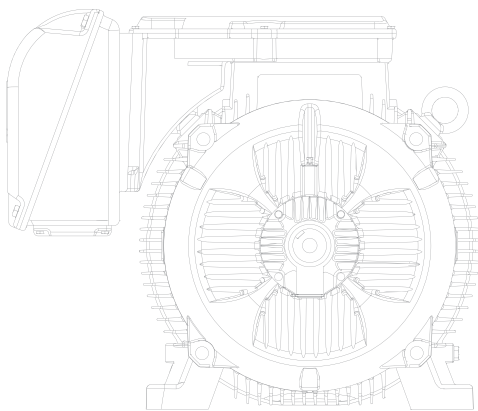

## Scope

The scope of the EuP motor regulation (which is more limited than that of the IEC 60034-30-1 standard), covers single speed, three-phase squirrel-cage induction motors for 50Hz or 50/60Hz operation which:

- Have 2, 4, or 6 poles
- Have a rated voltage ( $U_N$ ) up to 1000 V
- Have a rated output ( $P_N$ ) between 0,75 kW and 375 kW
- Are rated for continuous duty operation (S1)
- Are intended for use at altitudes up to 4,000 metres above sea level or at ambient air temperatures between -30°C and +60°C.

However, the Regulation does not apply to:

- a) Motors designed to operate wholly immersed in liquid
- b) Motors completely integrated into a product where its energy efficiency cannot be measured independently
- c) Motors designed to operate exclusively:
  - at altitudes greater than 4,000 metres above sea level
  - in ambient air temperatures exceeding 60°C
  - in maximum operating temperature above 400°C
  - where ambient air temperatures are below -30°C (or 0°C for water cooled motors)
  - where water coolant temperatures are below 0°C or above 32°C at the inlet to the product
  - in potentially explosive atmospheres defined in the Directive 94/9/EC

d) Brake motors

## Effective Dates

The implementation dates of the Regulation are as follows:

- Stage 1 - From 16 June 2011, motors shall not be less efficient than the IE2 efficiency level;
- Stage 2 - From 1 January 2015 motors with a rated output of 7,5-375 kW shall not be less efficient than the IE3 efficiency level (defined in Table 1) OR meet the IE2 efficiency level and operated / equipped with a variable speed drive;
- Stage 3 - From 1 January 2017 all motors with a rated output of 0,75-375 kW shall not be less efficient than the IE3 efficiency level OR meet the IE2 efficiency level and operated / equipped with a variable speed drive.

## Equipment Marking

Those IE2 motors which are required to be operate with a variable speed drive, must bear a sticker / label to ensure that the End User is made aware of the compulsory need to equip the motor with a VSD.

IE2 motors from WEG (0,75-375 kW) per Stage 3 of the Regulation are provided with a sticker as follows:



Output	IE1 - Standard Efficiency				IE2 - High Efficiency				IE3 - Premium Efficiency				IE4 - Super Premium Efficiency			
	Poles				Poles				Poles				Poles			
kW	2	4	6	8	2	4	6	8	2	4	6	8	2	4	6	8
0.12	45.0	50.0	38.3	31.0	53.6	59.1	50.6	39.8	60.8	64.8	57.7	50.7	66.5	69.8	64.9	62.3
0.18	52.8	57.0	45.5	38.0	60.4	64.7	56.6	45.9	65.9	69.9	63.9	58.7	70.8	74.7	70.1	67.2
0.20	54.6	58.5	47.6	39.7	61.9	65.9	58.8	47.4	67.2	71.1	65.4	60.6	71.9	75.5	71.4	68.4
0.25	58.2	61.5	52.1	43.4	64.8	68.5	61.6	50.6	69.7	73.5	68.6	64.1	74.3	77.9	74.1	70.8
0.37	63.9	66.0	59.7	49.7	69.5	72.7	67.6	56.1	73.8	77.3	73.5	69.3	78.1	81.1	78.0	74.3
0.40	64.9	66.8	61.1	50.9	70.4	73.5	68.8	57.2	74.6	78.0	74.4	70.1	78.9	81.7	78.7	74.9
0.55	69.0	70.0	65.8	56.1	74.1	77.1	73.1	61.7	77.8	80.8	77.2	73.0	81.5	83.9	80.9	77.0
0.75	72.1	72.1	70.0	61.2	77.4	79.6	75.9	66.2	80.7	82.5	78.9	75.0	83.5	85.7	82.7	78.4
1.1	75.0	75.0	72.9	66.5	79.6	81.4	78.1	70.8	82.7	84.1	81.0	77.7	85.2	87.2	84.5	80.8
1.5	77.2	77.2	75.2	70.2	81.3	82.8	79.8	74.1	84.2	85.3	82.5	79.7	86.5	88.2	85.9	82.6
2.2	79.7	79.7	77.7	74.2	83.2	84.3	81.8	77.6	85.9	86.7	84.3	81.9	88.0	89.5	87.4	84.5
3	81.5	81.5	79.7	77.0	84.6	85.5	83.3	80.0	87.1	87.7	85.6	83.5	89.1	90.4	88.6	85.9
4	83.1	83.1	81.4	79.2	85.8	86.6	84.6	81.9	88.1	88.6	86.8	84.8	90.0	91.1	89.5	87.1
5.5	84.7	84.7	83.1	81.4	87.0	87.7	86.0	83.8	89.2	89.6	88.0	86.2	90.9	91.9	90.5	88.3
7.5	86.0	86.0	84.7	83.1	88.1	88.7	87.2	85.3	90.1	90.4	89.1	87.3	91.7	92.6	91.3	89.3
11	87.6	87.6	86.4	85.0	89.4	89.8	88.7	86.9	91.2	91.4	90.3	88.6	92.6	93.3	92.3	90.4
15	88.7	88.7	87.7	86.2	90.3	90.6	89.7	88.0	91.9	92.1	91.2	89.6	93.3	93.9	92.9	91.2
18.5	89.3	89.3	88.6	86.9	90.9	91.2	90.4	88.6	92.4	92.6	91.7	90.1	93.7	94.2	93.4	91.7
22	89.9	89.9	89.2	87.4	91.3	91.6	90.9	89.1	92.7	93.0	92.2	90.6	94.0	94.5	93.7	92.1
30	90.7	90.7	90.2	88.3	92.0	92.3	91.7	89.8	93.3	93.6	92.9	91.3	94.5	94.9	94.2	92.7
37	91.2	91.2	90.8	88.8	92.5	92.7	92.2	90.3	93.7	93.9	93.3	91.8	94.8	95.2	94.5	93.1
45	91.7	91.7	91.4	89.2	92.9	93.1	92.7	90.7	94.0	94.2	93.7	92.2	95.0	95.4	94.8	93.4
55	92.1	92.1	91.9	89.7	93.2	93.5	93.1	91.0	94.3	94.6	94.1	92.5	95.3	95.7	95.1	93.7
75	92.7	92.7	92.6	90.7	93.8	94.0	93.7	91.6	94.7	95.0	94.6	93.1	95.6	96.0	95.4	94.2
90	93.0	93.0	92.9	91.1	94.1	94.2	94.0	91.9	95.0	95.2	94.9	93.4	95.8	96.1	95.6	94.4
110	93.3	93.3	93.3	91.5	94.3	94.5	94.3	92.3	95.2	95.4	95.1	93.7	96.0	96.3	95.8	94.7
132	93.5	93.5	93.5	91.9	94.6	94.7	94.6	92.6	95.4	95.6	95.4	94.0	96.2	96.4	96.0	94.9
160	93.8	93.8	93.8	92.5	94.8	94.9	94.8	93.0	95.6	95.8	95.6	94.3	96.3	96.6	96.2	95.1
200	94.0	94.0	94.0	92.5	95.0	95.1	95.0	93.5	95.8	96.0	95.8	94.6	96.5	96.7	96.3	95.4
250	94.0	94.0	94.0	92.5	95.0	95.1	95.0	93.5	95.8	96.0	95.8	94.6	96.5	96.7	96.5	95.4
315 up to 1000	94.0	94.0	94.0	92.5	95.0	95.1	95.0	93.5	95.8	96.0	95.8	94.6	96.5	96.7	96.6	95.4

Table 1 - Minimum efficiency levels (according to IEC 60034-30-1 : 2014).

WEG can support the movement towards these high efficiency levels by offering a comprehensive range of products meeting the IE1, IE2, IE3 and even IE4 criteria detailed above. Additionally our variable speed drives are perfectly matched to our motors, affording you the most reliable package of motor / drive products in industry. To learn more about WEG, our products and the new Global Directives, go to [www.weg.net](http://www.weg.net) or [www.weg.net/green](http://www.weg.net/green)

## Visual Index

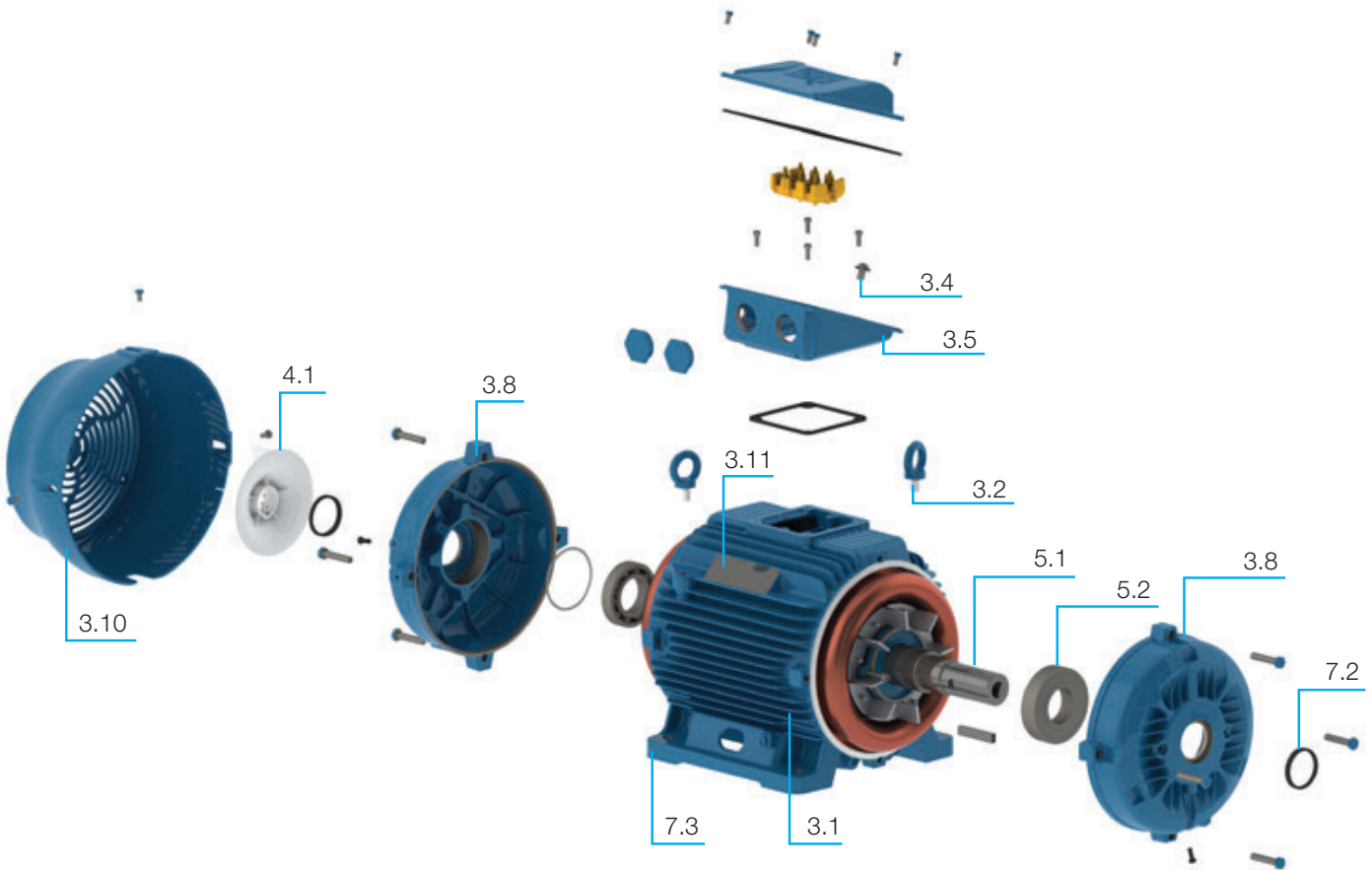

3.1	Frame	Page 9
3.2	Eyebolts	Page 10
3.4	Earth terminals	Page 10
3.5	Terminal box	Page 10
3.8	Endshields	Page 12
3.10	Fan cover	Page 12
3.11	Nameplate	Page 12
4.1	Cooling system	Page 13
5.1	Shaft	Page 14
5.2	Bearings	Page 14
7.2	Sealing system	Page 19
7.3	Painting	Page 19

Table 2 - Visual Index

## Table of Contents

1. Versions Available .....	8
2. Standards .....	9
3. Construction Details.....	9
3.1 Frame .....	9
3.2 Eyebolts .....	10
3.3 Points for Vibration Monitoring .....	10
3.4 Earth Terminals .....	10
3.5 Terminal Box .....	10
3.6 Power Supply Connection Leads .....	11
3.7 Accessory Connection Leads .....	11
3.8 Endshields .....	12
3.9 Drains.....	12
3.10 Fan Cover .....	12
3.11 Nameplate .....	12
4. Cooling System and Noise Level / Vibration Level / Impact Resistance.....	13
4.1 Cooling System and Noise Level .....	13
4.2 Vibration Level.....	14
4.3 Impact Resistance .....	14
5. Shaft / Bearings.....	14
5.1 Shaft.....	14
5.2 Bearings.....	14
5.2.1 Permissible Loads .....	15
5.2.2 Bearing Monitoring.....	18
6. Mounting Forms.....	18
7. Degree of Protection / Sealing System / Painting .....	18
7.1 Degree of Protection .....	18
7.2 Sealing System.....	19
7.3 Painting .....	19
7.3.1 Tropicalized Painting .....	19
8. Voltage / Frequency .....	19
9. Overload Capacity .....	20
10. Ambient and Altitude.....	20
11. Insulation & Temperature Rise .....	20
11.1 Space Heaters .....	20
12. Motor Protections.....	21
12.1 Protection Based on Operating Temperature.....	21
12.1.1 Pt-100.....	21
12.1.2 Thermistor (PTC) .....	21
12.1.3 Bimetallic Thermal Protectors .....	21
12.2 Protection Based on Operating Current .....	21
13. Variable Speed Drive Application .....	21
13.1 Considerations Regarding Voltage Spikes and the Insulation System .....	21
13.2 Influence of the VSD on the Motor Temperature.....	22
13.2.1 Torque Derating Criteria.....	22
13.2.2 Constant Flux Condition.....	22
13.2.3 Optimal Flux Condition .....	22
13.3 Considerations Regarding Bearing Currents .....	23
13.4 Forced Ventilation .....	23
13.5 Encoders.....	23
14. Tolerances for Electrical Data .....	23
15. Construction Features.....	24
16. Optional Features.....	26
17. Electrical Data.....	32
18. Mechanical Data .....	56
19. Terminal Box Drawings.....	62
20. Drip Cover Data .....	63
21. External Motor Dimensions with Forced Ventilation.....	63
22. Silencer.....	64
23. Packaging .....	65
24. Spare Parts.....	66

## 1. Versions Available

Meeting the legislative requirements of the European Market, W22 motors are available in three versions in accordance with IEC 60034-30-1 : 2014: High Efficiency (IE2), Premium Efficiency (IE3) and Super Premium Efficiency (IE4). Figure 1 shows the efficiency levels established by IEC 60034-30-1 : 2014 for induction motors.

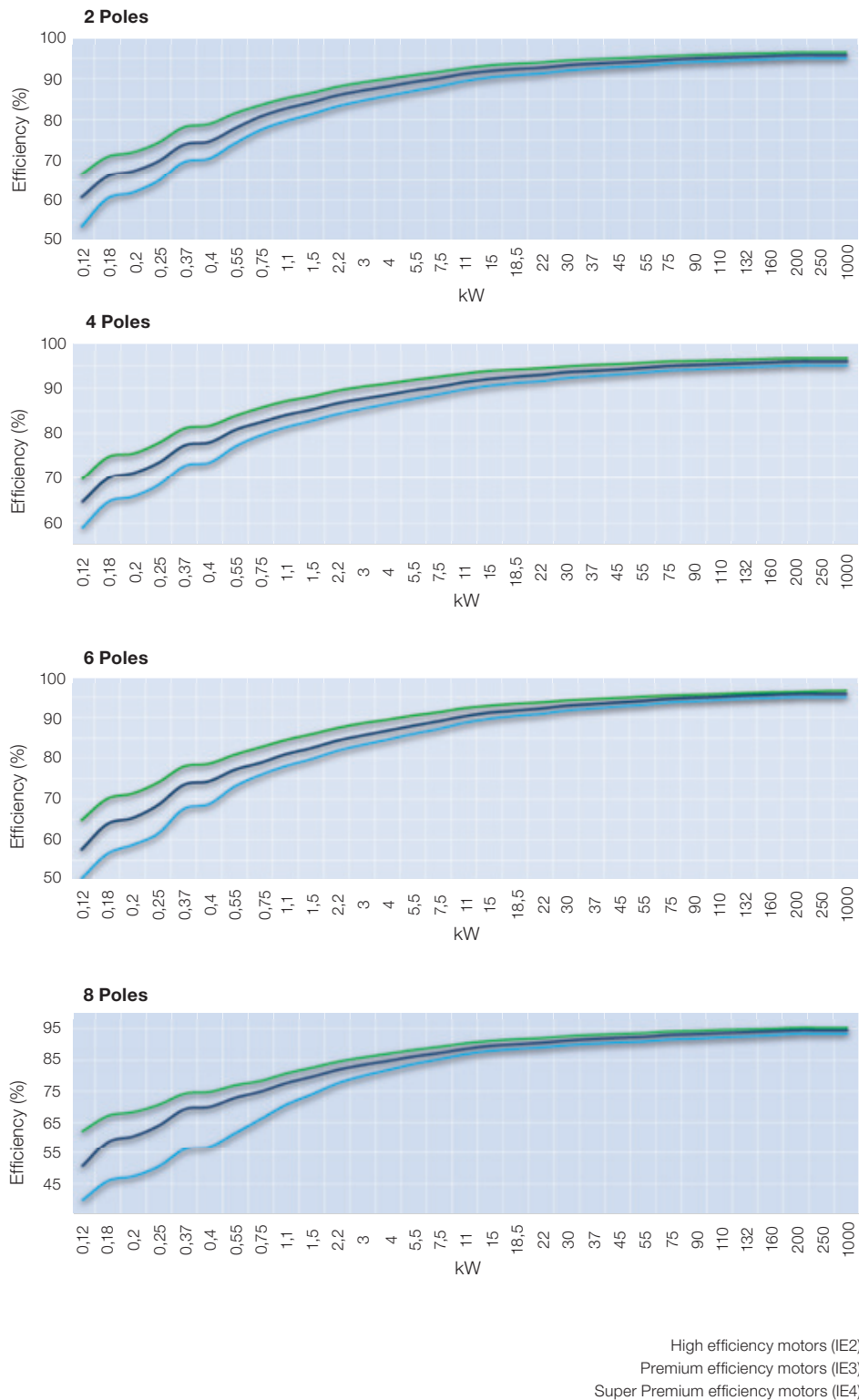

Figure 1 - Efficiency levels according to IEC 60034-30-1 : 2014



Efficiency values for W22 motors are prepared in accordance with the test standard IEC 60034-2-1:2014, with stray load losses determined directly by the summation of losses.

The output versus frame ratio for all W22 motors follows the EN 50347 standard, thus allowing direct replacement of existing lower efficiency motors with high (IE2), premium (IE3) or super premium (IE4) machines.

A further characteristic of the W22 electrical design is that it was conceived in such way that its efficiency remains practically constant in the 75% to 100% load range. Therefore, even when the motor is not running at full load its efficiency is not affected (see figure 2).

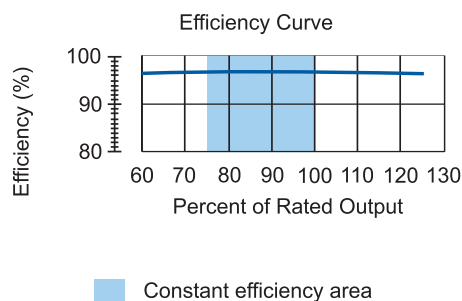

Figure 2 - Typical efficiency curve of W22 line

## 2. Standards

W22 motors meet the requirements and regulations of the latest versions of the following International Standards:

- IEC 60034-1 Rotating electrical machines - Part 1: Rating and performance.
- IEC 60034-2-1 Rotating electrical machines - Part 2-1: Standard methods for determining losses and efficiency from tests (excluding machines for traction vehicles).
- IEC 60034-5 Rotating electrical machines - Part 5: Degrees of protection provided by the integral design of rotating electrical machines (IP code) - classification.
- IEC 60034-6 Rotating electrical machines - Part 6: Methods of cooling (IC code).
- IEC 60034-7 Rotating electrical machines - Part 7: Classification of types of enclosures and mounting arrangements (IM code).
- IEC 60034-8 Rotating electrical machines - Part 8: Terminal markings and direction of rotation.
- IEC 60034-9 Rotating electrical machines - Part 9: Noise limits.
- IEC 60034-11-1 Rotating electrical machines - Part 11-1: Thermal protection.
- IEC 60034-12 Rotating electrical machines - Part 12: Starting performance of single-speed three-phase cage induction motors.

- IEC 60034-14 Rotating electrical machines - Part 14: Mechanical vibration of certain machines - Limits of vibration.
- IEC 60034-30-1 Rotating electrical machines - Part 30: Efficiency classes for single-speed three-phase cage induction motors.
- IEC 60072-1 Dimensions and output series for rotating electrical machines - Part 1: Frame numbers 56 to 400 and flange numbers 55 to 1080.
- EN 50347 General purpose three-phase induction motors having standard dimensions and outputs - frame numbers 56 to 315 and flange numbers 65 to 740.

## 3. Construction Details

The information included in this technical catalogue refers to the standard construction features and most common variations for W22 low voltage general purpose motors in frame sizes from IEC 63 to 355A/B. W22 motors for special and/or customized applications are available on request. For more information, please contact your WEG office or distributor.

### 3.1 Frame

The W22 frame (figure 3) is manufactured in FC-200 (EN GJL 200) cast iron providing high levels of mechanical strength to cater for the most demanding applications. The cooling fins are designed to minimize the accumulation of liquids and dust on the motor.



Figure 3 - W22 Frame

The motor feet are completely solid for optimal mechanical strength (figure 4), allowing easier alignment and installation.

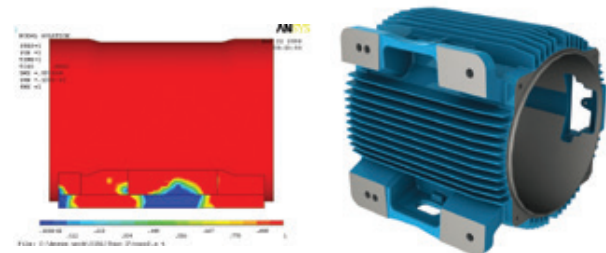

Figure 4 - Solid feet

### 3.2 Eyebolts

Eyebolts are provided as standard from frame size 100L. The positions of the eyebolts are shown in the table 3:

Number of eyebolts	Description
1	Frames 100L to 200L Motors with feet and with side mounted terminal box
2	Frames 100L to 200L Motors with feet and with top mounted terminal box
2	Frames 100L to 200L - Motors without feet and with C or FF flange
2	Frames 225S/M to 355A/B - Motors with feet and side or top mounted terminal box. These motors have four threaded holes in the upper part of the frame for fastening of the eyebolts (figure 5)
2	Frames 225S/M to 355A/B - Motors without feet and with C or FF flange. These motors have four threaded holes in the upper part of the frame for fastening of the eyebolts and two more threaded holes in the bottom part

Table 3 - Eyebolts

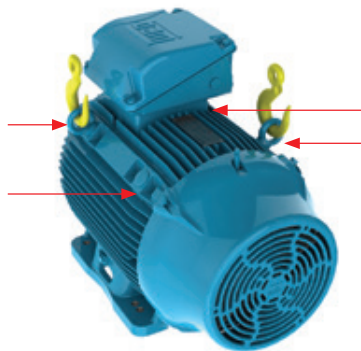

Figure 5 - Motor with four threaded holes for fastening of the eyebolts

### 3.3 Points for Vibration Monitoring

To allow easy maintenance, specifically vibration testing, the 160 to 355 frames are designed with flat areas on both ends for better placement of accelerometers (figure 6). These flat areas are provided in both vertical and horizontal planes. As an option M8 threads for SPM accelerometers can be supplied.

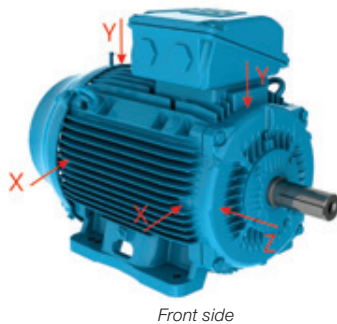

Figure 6 - Flat surfaces for vibration monitoring on the top, front and side.

### 3.4 Earth Terminals

All frames from 63 to 355A/B are provided with an earth terminal located inside the terminal box (see figure 7).

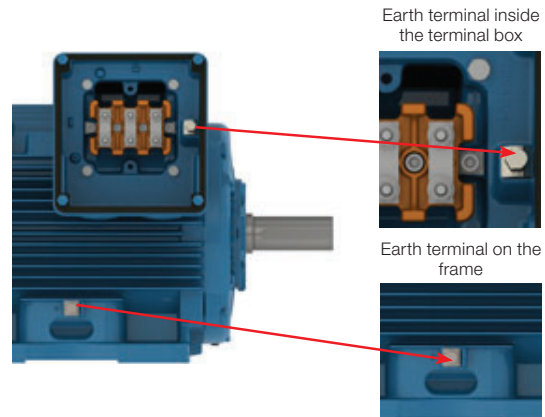

Figure 7 - Earth terminal inside the terminal box

Motors in frames 225S/M to 355A/B are also fitted with an earth terminal on the frame. It is located on the same side of the main terminal box cable entry (see figure 7) and is responsible to equalize electrical potential and provide greater safety for operators. Capable of terminating cables from 25 mm<sup>2</sup> to 185 mm<sup>2</sup>.

Optionally, an external earth terminal can be provided for motors in frame sizes 63-200, and, for frame sizes 160M/L to 355A/B a second external earth terminal as indicated in figure 8.

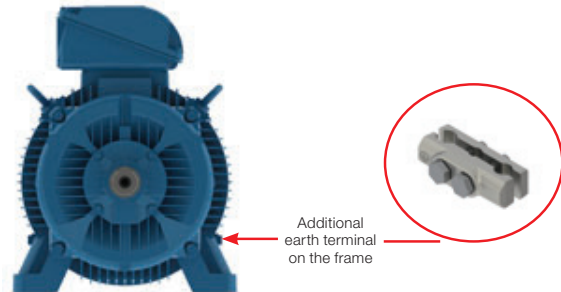

Figure 8 - Additional earth terminal position on the frame.

### 3.5 Terminal Box

The terminal box of W22 motors produced in FC-200 (EN GJL 200) cast iron, which is the same material used for the frame and endshields. It is diagonally split for easier handling of leads and connections. For the frame size range 63 to 200 the terminal box position is centralized on the motor frame and can be supplied in two configurations - top (standard) or left / right side (optional). A motor with a side mounted terminal box (B3R or B3L) can have the terminal box position located on the opposite side through modification. For frame sizes 225S/M to 355A/B the terminal box is positioned towards the drive end of the motor and on top as standard.

This arrangement allows improvement of the airflow over the

cooling fins, thus reducing motor operating temperatures. Terminal box position on either the left or right hand side of the motor is possible through the use of an adaptor (see figure 9).

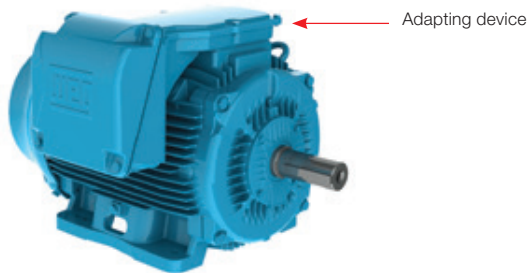

Figure 9 - Terminal box mounted on the left side viewing from drive end shaft

When supplied from the factory with a side mounted terminal box arrangement, this can be positioned on the opposite side simply by rotating the adaptor.

Similarly, by removing the adaptor and adjusting the length of the motor leads, the terminal box can be positioned on top of the motor.

The flexibility of terminal box positions on the W22 motor offered by the adaptor can be seen in figure 10.



Figure 10 - Terminal box mounted on both sides and on top (versatility)

Conversely, factory supplied motors with the terminal box position on top can be modified to side mounting by fitting the adaptor and extending the motor leads.

**Note: For all terminal box position modifications please contact WEG or your local WEG service centre.**

For all frames, the terminal box can be rotated in 90° increments. Motors in IEC frame sizes 315L, 355M/L and 355A/B are supplied as standard with removable cast iron cable gland plates. As an option, the gland plates can be supplied undrilled.

Motors are supplied with plastic threaded plugs in the cable glands to maintain the degree of protection during transport and storage.

In order to guarantee the degree of protection, cable glands must comply with at least the same degree of protection as that indicated on the motor nameplate. Lack of compliance with such detail can invalidate the motor warranty. If required, please contact the WEG Service Area for further advice.

### 3.6 Power Supply Connection Leads

Motor power supply leads are marked in accordance with IEC 60034-8 and are connected to a terminal block made from a polyester based resin BMC (Bulk Moulding Compound), duly reinforced with fibre glass (see figure 11).



Figure 11 - BMC terminal block

Motors in frame size 355A/B are provided with a staggered terminal block arrangement, as indicated in figure 12.

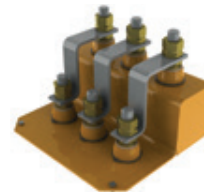

Figure 12 - 355A/B staggered terminal block

### 3.7 Accessory Connection Leads

Accessory terminals are assembled onto connectors whenever the motor is supplied with a terminal block. They may be assembled inside the main power terminal box or in a separate accessory terminal box (figure 13).

Whether the accessory terminals are assembled inside the main power or a separate terminal box, an M20 x 1.5 threaded hole is provided for fitting of cable glands for the incoming connection leads.

In the Terminal Box Drawings section of this technical catalogue it is possible to check the permissible number of connectors which may be assembled inside the main power and accessory terminal boxes.



Figure 13 - Accessory terminal box attached to power terminal box

For all frame sizes, there is also the option of providing a dedicated terminal box for the connection of space heaters, or two separate accessory terminal boxes, as shown in figure 14.

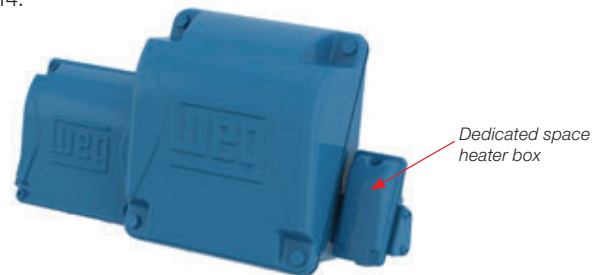

Figure 14 - Two accessory terminal boxes attached to power terminal box

### 3.8 Endshields

The drive end endshield (figure 15) is designed with fins for improved thermal heat dissipation, to ensure lower bearing operating temperatures, resulting in extended lubrication intervals. For the frames 225S/M to 355A/B, where ventilation is critical for thermal performance of the motor, the endshield fastening screws are located in such a way so as not to obstruct the airflow across any cooling fin, thus contributing to better thermal exchange.

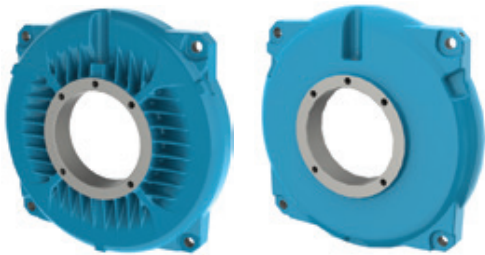

Figure 15 - Drive and non-drive endshields

### 3.9 Drains

The endshields have holes for drainage of any water that may condense inside of the frame. These holes are supplied with rubber drain plugs, as indicated in figure 16. These plugs leave the factory in the closed position and must be opened periodically to allow the exit of condensed water.

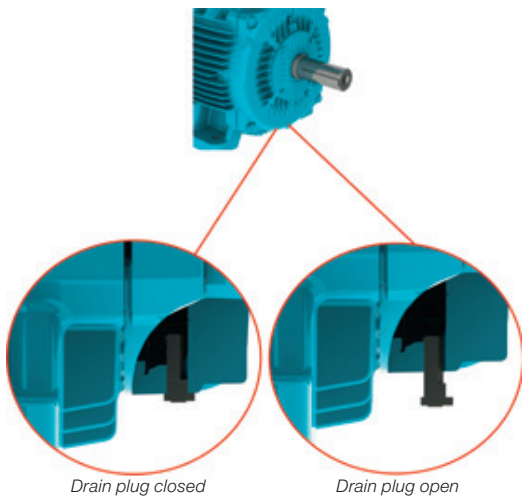

Figure 16 - Detail of the drain plug position on drive endshield.

### 3.10 Fan Cover

The fan cover is made of steel for frames 63 to 132 and FC-200 (EN GJL 200) cast iron for frames 160 to 355. The cast iron fan covers have an aerodynamic design, which results in a significant reduction in noise level and optimized airflow between frame fins for heat exchange improvement. Figure 17 shows the aerodynamic design of the cast iron fan cover.



Figure 17 - Fan cover

### 3.11 Nameplate

The nameplate details information relating to the construction and performance characteristics of the motor. It is also necessary to indicate on the nameplate the IE code and nominal efficiency of the motor at full load (and 3/4 and 1/2 load where space permits), as required by IEC 60034-30-1.

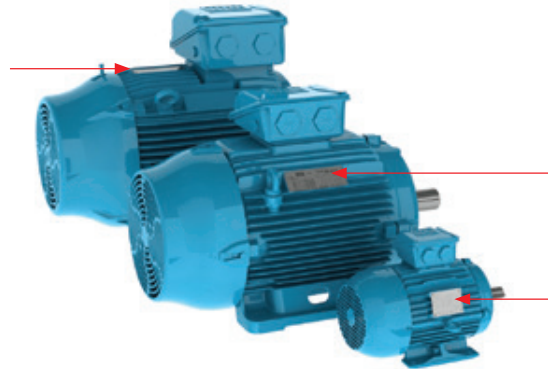

Figure 18 - Nameplate position of W22 motors

W22 Premium												1 → 11459166	
04AGO14												0000000000	
2 → 3 ~ 132M-04	IP55	INS	CL	F	Δ	T	80	K	S1	16 → SF 1.00	AMB 40°C	←15	
V	10 → Hz	kW	RPM	13 → A	14 → PF	IE code		100%	75%	50%	←27		
380 Δ / 660 Y	50	7.5	1460	14.4	8.29	0.86	5	91.2	91.5	91.4			
400 Δ / 690 Y			1465	13.9	8.06	0.84		91.5	91.5	91.0			
415 Δ / -			1470	13.5	-	0.83		91.7	91.0	90.2			
460 Δ / -	60	11	1770	12.2	-	0.83							
NEMA Eff 91.7% 10HP 460V 60Hz 1770 RPM												6308-ZZ ←19	
12.2 A PF 0.83 Des A Code K SF 1.15 CC029A												6207-ZZ ←20	
W2 U2 V2 W2 U2 V2												MOBIL POLYREX EM ←21	
U1 V1 W1 U1 V1 W1												ALT 1000 m.a.s.l. ←17	
Δ L1 L2 L3 Y L1 L2 L3												82 kg ←18	
MOD.TE1BFOX0\$												IEC 60034-1	

Figure 19 - Nameplate layout for frames 63 to 132

W22 Premium												25, 26	
04AGO14												MOD.TE1BFOX0\$	
2 → 3 ~ 132M-04	IP55	INS	CL	F	Δ	T	80	K	S1	16 → SF 1.00	AMB 40°C	←15	
V	10 → Hz	kW	RPM	13 → A	14 → PF	IE code		100%	75%	50%	←27		
380 Δ / 660 Y	50	11.0	1489	20.1	11.6	0.87	5	95.5	95.5	95.0			
400 Δ / 690 Y			1490	19.3	11.2	0.86		95.6	95.5	94.7			
415 Δ / -			1490	18.9	-	0.85		95.8	95.0	93.7			
460 Δ / -	60	17.95	170	-	-	0.85							
NEMA Eff 95.8% 150HP 460V 60Hz 1795 RPM												170 A PF 0.85 Des A Code H SF 1.15 CC029A	
MOBIL POLYREX EM ←21												ALT 1000 m.a.s.l. ←17	
U1 V1 W1 U1 V1 W1												987 kg ←18	
Δ L1 L2 L3 Y L1 L2 L3													

Figure 20 - Nameplate layout for frames 160 to 355

- 1 - Motor code
- 2 - Number of phases
- 3 - Rated operating voltage
- 4 - Service duty
- 5 - Efficiency Code - IE
- 6 - Frame size
- 7 - Degree of protection
- 8 - Insulation class
- 9 - Temperature rise
- 10 - Frequency
- 11 - Motor rated power
- 12 - Full load speed (rpm)
- 13 - Rated operating current
- 14 - Power factor
- 15 - Ambient temperature
- 16 - Service factor
- 17 - Altitude
- 18 - Motor weight
- 19 - Drive end bearing type and amount of grease (where applicable)
- 20 - Non-drive end bearing type and amount of grease (where applicable)
- 21 - Type of grease for bearings
- 22 - Connection diagram
- 23 - Relubrication intervals in hours
- 24 - Certification labels
- 25 - Manufacturing date
- 26 - Serial number
- 27 - Partial load efficiencies

## 4. Cooling System and Noise Level / Vibration Level / Impact Resistance

### 4.1 Cooling System and Noise Level

The W22 standard motors are totally enclosed fan cooled (TEFC - IC 411), as per IEC 60034-6 (figure 21). Non-ventilated versions (TENV - IC 410), air over (TEAO - IC 418) and motors with forced ventilation (TEBC - IC416) are available on request. Further information regarding the TEBC - IC 416 option can be found in section 13 - Variable speed drive application.



Figure 21 - Cooling system

The cooling system (fan, non drive endshield and fan cover) is designed to minimize the noise level and improve thermal efficiency (figure 22).

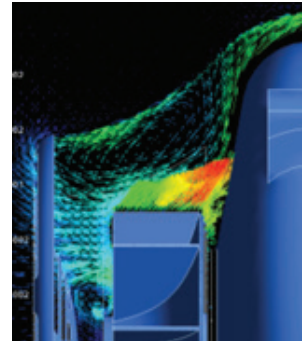

Figure 22 - Cooling system operation

W22 motors comply with IEC 60034-9 Standard and the corresponding sound pressure levels. Tables 4 and 5 show sound pressure levels in dB(A) which are obtained upon tests at 50 Hz and 60 Hz.

Frame	IEC 50 Hz			
	Sound pressure level - dB(A) at 1 meter			
	2 poles	4 poles	6 poles	8 poles
63	52	44	43	-
71	56	43	43	41
80	59	44	43	42
90	64/ 62(*)	49	45	43
100	67	53	44	50
112	64	56	48	46
132	68/ 67(*)	60/ 56(*)	52	48
160	67	61	56	51
180	67	61	56	51
200	72/ 69(*)	65/ 63(*)	60	53
225	75/ 74(*)	66/ 63(*)	61	56
250	75/ 74(*)	66/ 64(*)	61	56
280	77	69	65	59
315S/M	77	71	67	61
315 L	78	74/ 73(*)	68	61
355M/L	80	76/ 74(*)	73	70
355A/B	83	76	73	70

(\*) Values for IE3 and IE4 motors.

Table 4 - Sound pressure levels for 50 Hz motors

Frame	IEC 60 Hz			
	Sound pressure level - dB(A) at 1 meter			
	2 poles	4 poles	6 poles	8 poles
63	56	48	47	-
71	60	47	47	45
80	62	48	47	46
90	68	51	49	47
100	71	54	48	54
112	69	58	52	50
132	72	61	55	52
160	72	64	59	54
180	72	64	59	54
200	76/ 74(*)	68/ 66(*)	62	56
225	80/ 79(*)	70/ 67(*)	64	60
250	80/ 79(*)	70/ 68(*)	64	60
280	81	73	69	63
315S/M	81	75	70	64
315L	82	79/ 77(*)	71	64
355M/L	84	81/ 78(*)	77	75
355A/B	89	81	77	75

(\*) Values for IE3 and IE4 motors.

Table 5 - Sound pressure levels for 60 Hz motors

The noise level values shown in tables 4 and 5 are taken at 1 metre at no load. Under load the IEC 60034-9 Standard foresees an increase of the sound pressure levels as shown in table 6.

Frame (mm)	2 poles	4 poles	6 poles	8 poles
90 ≤ H ≤ 160	2	5	7	8
180 ≤ H ≤ 200	2	4	6	7
225 ≤ H ≤ 280	2	3	6	7
H = 315	2	3	5	6
355 ≤ H	2	2	4	5

Table 6 - Maximum expected increase of sound pressure level for loaded motors.

Note: These values refer to operating frequencies of 50 Hz and 60 Hz.  
The overall noise level can be reduced by up to 2 dB (A) with the installation of a drip cover.

#### 4.2 Vibration Level

Vibration of an electrical machine is closely related to its assembly on the application and, thus, it is generally desirable to perform vibration measurements under installation and operational conditions. However, to allow evaluation of the vibration generated by the electrical machine itself in a way to allow reproducibility of the tests and the obtaining of comparative measurements, it is necessary to perform such measurements with the machine uncoupled, under controlled test conditions. The test conditions and vibration limits described here are those found in IEC 60034-14. The severity of vibration is the maximum value of vibration found among all the recommended measurement points and directions. Table 7, below, indicates the recommended admissible values of vibration severity under IEC standard 60034-14 for the frames IEC 56 to 400, for degrees of vibration A and B.

W22 motors (> frame 80, 2P and > frame 71, 4P and up) are dynamically balanced with half key and the standard version meets the vibration levels of Grade A (without special vibration requirements) described in IEC 60034-14 Standard. As an option, motors can be supplied in conformance with vibration of Grade B. The RMS speed and vibration levels in mm/s of Grades A and B are shown in table 7.

Vibration	Frame	56 ≤ H ≤ 132	132 < H ≤ 280	H > 280
	Assembly	Vibration speed RMS (mm/s)	Vibration speed RMS (mm/s)	Vibration speed RMS (mm/s)
Grade A	Free suspension	1.6	2.2	2.8
Grade B	Free suspension	0.7	1.1	1.8

Table 7 - Speed and vibration levels

#### 4.3 Impact Resistance

The W22 motor complies with impact level IK08 (mechanical impact of 5J) as defined in EN 62262 : 2002 - Degrees of protection provided by enclosures for electrical equipment against external mechanical impacts (IK code) - therefore ensuring superior mechanical strength for the most demanding applications.

## 5. Shaft / Bearings

### 5.1 Shaft

The shaft steel material for W22 standard motors is AISI 1040/45, in frames IEC 63 to 315S/M, and AISI 4140 for frames 315L, 355M/L and 355A/B. When supplied with roller bearings, the shaft material must be AISI 4140. Information regarding the maximum allowable radial and axial loads on shaft ends is given in tables 9, 10 and 11.

Important: when equipped with a roller bearing, it is necessary to lock the non drive end bearing which obliges replacement of the non drive end bearing cap.

Shafts of W22 motors are supplied with an open profile keyway, with a threaded centre hole, and can optionally be provided with a second shaft end. Dimensions of motor shafts can be found in section 17 - Mechanical Data.

For highly corrosive environments, W22 motors may also be supplied with AISI 316 or AISI 420 stainless steel shafts.

Note: 2 pole motors will have as an option only the shaft end in stainless steel AISI 316.

### 5.2 Bearings

W22 motors are supplied with deep groove ball bearings as standard (figure 23). Optionally, for frame sizes 160 and above, NU series roller bearings can be fitted to motors intended for heavy duty applications where high radial loads may occur e.g. pulley and belt drives.

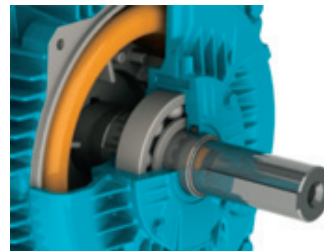

Figure 23 - Ball bearing view

The nominal bearing life L10h is 20000 or 40000 hours in conformance with maximum radial and axial loads as described in tables 9, 10 and 11. When direct coupled to the load (without axial or radial thrusts), the L10h bearing life can be extended to 50000\* hours.

\* For regreasable motors. Other configurations contact WEG.

In standard configuration, with ball bearings, the drive end bearing is locked axially from frame 160. To compensate for any axial movement the motors are fitted with pre-load washers for frames 63 to 200 and with pre-load springs for frames 225 to 355. When provided with roller bearings, the non-drive end bearing is locked and the axial movement is compensated by the axial play of the front roller bearing. Minimum and maximum admissible radial loads for roller bearings are shown in table 10 on page 16.

The lifetime of the bearing is dependent on its type and size,

the radial and axial mechanical loads it is submitted to, operating conditions (environment, temperature, mounting orientation), rotational speed and grease life. Therefore, bearing lifetime is closely related to its correct use, maintenance and lubrication. Respecting the quantity of grease and lubrication intervals allows bearings to reach the indicated lifetime. W22 motors in IEC frames 225S/M and above are provided as standard with grease fittings in each endshield to permit the relubrication of the bearings (optional for frames 90-200). The quantity of grease and lubrication intervals are stamped on the motor nameplate. The lubrication intervals are shown in tables 12 and 13 on page 17. It must be emphasized that excessive lubrication, i.e. a quantity of grease greater than that recommended on the motor nameplate, can result in the increase of bearing temperatures leading to reduced operating hours.

**Note:**

1. L10h lifetime means that at least 90% of the bearings submitted to the maximum indicated loads will reach the number of hours indicated. The maximum admissible radial and axial loads for the standard configuration are shown in tables 9, 10 and 11. The values of the maximum radial load consider axial load as nil. The values of the maximum axial load consider radial load as nil. For bearing lifetimes with combined axial and radial loads condition contact WEG.
2. The radial force value  $F_r$  usually results from information recommended in the catalogues of pulley / belt manufacturers.

When this information is not available, the force  $F_r$ , under operation, can be calculated based on the output power, on coupling design characteristics with pulleys and belts and on the type of application. So we have:

$$F_r = \frac{19,1 \times 10^6 \times P_n}{n_n \times dp} \times ka \text{ (N)}$$

Where:

- $F_r$  is the radial force caused by pulley and belt coupling [N];
- $P_n$  is the motor rated power [kW];
- $n_n$  is the motor rated speed per minute [rpm];
- $dp$  is the pitch diameter of the drive pulley [mm];
- $ka$  is a factor that depends on belt tension and type of application (table 8).

Groups and basic types of application		ka factor of the application	
		V belts	Plane belts
1	Fans and blowers, centrifugal pumps, winding machines, compressors, machine tools with outputs up to 22 kW (30 HP)	2.0	3.1
2	Fans and blowers, centrifugal pumps, winding machines, compressors, machine tools with outputs higher than 22 kW (30 HP)	2.4	3.3
3	Presses, vibrating screens, piston and screw compressors, pulverisers, helicoidal conveyors, woodworking machines, textile machines, kneading machines, ceramic machines, pulp and paper industrial grinders (for all power range).	2.7	3.4
4	Overhead cranes, hammer mills, metal laminators, conveyors, gyratory crushers, jaw crushers, cone crushers, cage mills, ball mills, rubber mixers, mining machines, shredders (for all power range).	3.0	3.7

Table 8 - ka factor

**Important:**

**1 - Special applications**

Motor operation under adverse operating conditions, such as higher ambient temperatures and altitudes or abnormal axial / radial loads, may require specific lubrication measures and alternative relubrication intervals to those indicated in the tables provided within this technical catalogue.

**2 - Roller bearings**

Roller bearings require a minimum radial load so as to ensure correct operation. They are not recommended for direct coupling arrangements, or for use on 2 pole motors.

**3 - Frequency inverter driven motors**

Bearing life may be reduced when a motor is driven by a frequency drive at speeds above nominal. Speed itself is one of the factors taken into consideration when determining motor bearing life.

**4 - Motors with modified mounting configurations**

For motors supplied with horizontal mounting but working vertically, lubrication intervals must be reduced by half.

**5 - Figures for radial thrusts**

The figures given in the tables below for radial thrusts take into consideration the point upon which the load is applied, either at the centre of the shaft (L/2) or at the end of the shaft (L), figure 24.

Note: On motors with second shaft end, refer to WEG for details of the maximum permissible axial and radial loads.

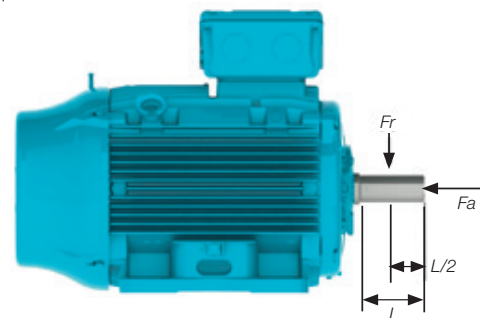

Figure 24 - Radial and axial thrust on motor shaft

**5.2.1 Permissible Loads**

**Radial Thrust - Ball Bearings**

Frame	Maximum permissible radial thrust - 50 Hz - $F_r$ in (kN) 20000 hours							
	2 poles		4 poles		6 poles		8 poles	
	L	L/2	L	L/2	L	L/2	L	L/2
63	0.3	0.4	0.3	0.4	0.3	0.4	0.3	0.4
71	0.5	0.5	0.5	0.6	0.5	0.6	0.6	0.7
80	0.6	0.6	0.7	0.7	0.7	0.8	0.8	1.0
90	0.6	0.7	0.7	0.8	0.8	0.9	0.9	1.0
100	0.9	1.0	1.0	1.1	1.2	1.3	1.3	1.4
112	1.2	1.3	1.4	1.5	1.6	1.8	1.7	1.9
132	1.8	2.0	2.2	2.4	2.4	2.7	2.6	2.9
160	2.3	2.6	2.6	2.9	2.7	3.3	2.7	3.7
180	3.1	3.5	3.6	4.0	4.2	4.7	4.2	5.2
200	3.7	4.0	4.2	4.7	4.9	5.4	5.7	6.2
225	5.1	5.5	5.2	6.3	5.3	7.0	5.7	8.1
250	4.9	5.3	5.2	5.7	6.5	7.1	6.0	8.2
280	5.0	5.4	6.7	7.2	7.8	8.4	8.7	9.4
315S/M	4.3	4.7	7.0	7.7	8.1	8.8	9.0	9.8
315L	4.6	5.0	4.0	7.3	6.2	8.2	9.1	9.8
355M/L	4.8	5.1	8.5	9.3	9.6	10.4	11.6	12.6
355A/B	4.5	4.7	5.1	7.4	7.4	8.0	6.9	10.6

Table 9.1 - Maximum permissible radial thrusts for ball bearings (horizontal mounting)

**Radial Thrust - Ball Bearings**

Maximum permissible radial thrust - 50 Hz - Fr in (kN) 40000 hours								
Frame	2 poles		4 poles		6 poles		8 poles	
	L	L/2	L	L/2	L	L/2	L	L/2
63	0.2	0.2	0.3	0.3	0.3	0.4	0.3	0.4
71	0.3	0.3	0.4	0.4	0.5	0.5	0.5	0.6
80	0.5	0.5	0.5	0.6	0.6	0.6	0.7	0.7
90	0.5	0.5	0.5	0.6	0.6	0.7	0.7	0.8
100	0.7	0.7	0.7	0.8	0.9	1.0	1.0	1.1
112	0.9	1.0	1.0	1.1	1.2	1.4	1.3	1.4
132	1.4	1.6	1.6	1.8	1.8	2.0	2.0	2.2
160	1.8	2.0	1.9	2.1	2.2	2.4	2.5	2.7
180	2.4	2.7	2.7	3.0	3.2	3.5	3.6	3.9
200	2.8	3.0	3.2	3.5	3.7	4.0	4.3	4.7
225	3.9	4.3	4.3	4.7	4.7	5.2	5.6	6.2
250	3.7	4.1	3.8	4.2	4.9	5.4	5.7	6.3
280	3.8	4.1	4.9	5.4	5.8	6.3	6.5	7.0
315S/M	3.1	3.4	4.9	5.4	5.7	6.2	6.3	6.9
315L	3.4	3.6	4.0	4.9	5.1	5.5	6.4	6.9
355M/L	3.3	3.6	5.8	6.3	6.5	7.1	8.2	8.9
355A/B	3.0	3.2	4.1	4.4	4.2	4.5	5.3	6.8

Table 9.2 - Maximum permissible radial thrusts for ball bearings (horizontal mounting).

**Radial Thrust - Roller Bearings**

Maximum permissible radial thrust - 50 Hz - Fr in (kN) 40000 hours						
Frame	4 poles		6 poles		8 poles	
	L/2	L	L/2	L	L/2	L
160	5,0	3,2	5,1	3,3	5,1	3,3
180	8,8	5,5	8,8	5,6	8,8	5,6
200	11,2	7,3	11,2	7,4	11,3	7,4
225S/M	12,9	7,6	12,9	7,6	13,0	7,8
250S/M	13,7	8,9	13,8	8,9	13,7	8,9
280S/M	19,3	12,6	19,4	12,8	19,6	12,9
315S/M	25,8	12,9	27,4	13,0	27,4	13,2
315L	21,5	10,1	20,1	9,4	26,1	12,2
355M/L	34,0	17,3	33,5	16,4	33,5	16,1
355A/B	31,4	14,9	25,4	12,0	28,4	13,5

Table 10 - Maximum permissible radial thrusts for roller bearings (horizontal mounting)

Note: the values given for roller bearings consider AISI 4140 steel shafts.



**Axial Thrust - Ball Bearings**

Maximum permissible axial thrust - 50 Hz - Fa in (kN) - 20000 hours							
Frame	Poles	Horizontal		Vertical with shaft upwards		Vertical with shaft downwards	
		Pushing	Pulling	Pushing	Pulling	Pushing	Pulling
63	2	0.2	0.2	0.2	0.2	0.2	0.2
	4	0.3	0.3	0.3	0.3	0.3	0.3
	6	0.3	0.4	0.3	0.4	0.4	0.3
	8	0.3	0.4	0.3	0.4	0.4	0.3
71	2	0.2	0.3	0.2	0.3	0.2	0.3
	4	0.3	0.4	0.3	0.4	0.3	0.4
	6	0.4	0.5	0.4	0.5	0.4	0.5
	8	0.5	0.6	0.4	0.6	0.5	0.6
80	2	0.3	0.4	0.3	0.4	0.3	0.4
	4	0.4	0.6	0.3	0.6	0.4	0.5
	6	0.5	0.7	0.4	0.7	0.5	0.7
	8	0.6	0.8	0.5	0.9	0.6	0.8
90	2	0.4	0.4	0.3	0.5	0.4	0.4
	4	0.5	0.6	0.5	0.7	0.5	0.6
	6	0.6	0.7	0.6	0.8	0.6	0.7
	8	0.8	0.9	0.7	0.9	0.8	0.8
100	2	0.4	0.6	0.3	0.7	0.4	0.6
	4	0.5	0.8	0.4	0.9	0.5	0.8
	6	0.7	1.0	0.6	1.1	0.7	1.0
	8	0.8	1.2	0.7	1.3	0.8	1.1
112	2	0.5	0.8	0.5	0.9	0.6	0.7
	4	0.7	1.1	0.7	1.2	0.8	1.0
	6	1.0	1.4	0.9	1.5	1.0	1.3
	8	1.1	1.5	1.0	1.7	1.1	1.4
132	2	0.7	1.3	0.6	1.5	0.8	1.2
	4	1.0	1.8	0.8	2.1	1.0	1.7
	6	1.2	2.2	1.1	2.5	1.3	2.1
	8	1.4	2.5	1.2	2.8	1.4	2.3
160	2	2.4	1.7	0.2	2.1	2.8	1.5
	4	3.0	2.3	2.7	2.7	3.4	2.0
	6	3.4	2.7	3.1	3.3	4.0	2.4
	8	3.9	3.2	3.6	3.7	4.4	2.9
180	2	3.2	2.3	2.9	2.8	3.7	2.0
	4	3.9	3.0	3.6	3.7	4.6	2.7
	6	4.7	3.8	4.2	4.5	5.3	3.3
	8	5.2	4.4	4.8	5.1	6.0	3.9
200	2	3.6	2.6	3.1	3.3	4.3	2.1
	4	4.5	3.5	4.0	4.3	5.3	3.0
	6	5.2	4.2	4.7	5.1	6.1	3.7
	8	6.0	5.0	5.5	5.9	6.9	4.5
225	2	4.6	3.8	3.8	4.9	5.7	3.1
	4	5.8	5.0	5.0	6.3	7.1	4.2
	6	6.7	5.9	5.7	7.6	8.4	4.9
	8	7.8	7.0	6.9	8.5	9.3	6.1
250	2	4.5	3.7	3.7	4.9	5.6	3.0
	4	5.4	4.7	4.2	6.6	7.4	3.4
	6	6.8	6.0	5.4	8.0	8.8	4.6
	8	7.8	7.1	6.6	8.9	9.7	5.9
280	2	4.4	3.7	3.2	5.4	6.2	2.4
	4	6.3	5.5	4.6	8.0	8.8	3.9
	6	7.6	6.8	5.8	9.4	10.2	5.0
	8	8.5	7.8	6.6	10.6	11.4	5.8
315S/M	2	4.1	3.3	2.4	5.9	6.7	1.6
	4	6.8	6.0	4.3	10.0	10.7	3.5
	6	8.0	7.2	5.2	11.9	12.7	4.5
	8	9.1	8.3	6.2	13.2	14.0	5.5
315L	2	3.0	2.2	1.1	5.0	5.7	0.4
	4	4.5	3.7	1.4	8.2	8.9	0.6
	6	5.2	4.4	1.9	9.5	10.3	1.2
	8	6.3	5.5	3.4	10.0	10.8	2.6
355M/L	2	4.4	3.7	1.1	8.8	9.5	0.3
	4	7.7	7.0	3.2	13.9	14.7	2.5
	6	9.1	8.4	4.7	15.3	16.0	3.9
	8	10.9	10.2	6.4	17.2	17.9	5.7
355A/B	2	4.1	3.3				
	4	6.8	6.0				
	6	7.8	7.0				
	8	9.8	9.0				

Table 11.1 - Maximum permissible axial thrusts for ball bearings (horizontal mounting).



**Axial Thrust - Ball Bearings**

Maximum permissible axial thrust - 50 Hz - Fa in (kN) - 40000 hours							
Frame	Poles	Horizontal		Vertical with shaft upwards		Vertical with shaft downwards	
		Pushing	Pulling	Pushing	Pulling	Pushing	Pulling
		2	0.1	0.1	0.1	0.1	0.1
63	4	0.2	0.2	0.2	0.2	0.2	0.2
	6	0.2	0.2	0.2	0.2	0.2	0.2
	8	0.2	0.2	0.2	0.2	0.2	0.2
71	2	0.1	0.2	0.1	0.2	0.1	0.2
	4	0.2	0.3	0.2	0.3	0.2	0.2
	6	0.2	0.3	0.2	0.3	0.2	0.3
80	8	0.3	0.4	0.3	0.4	0.3	0.4
	2	0.2	0.3	0.1	0.3	0.2	0.3
	4	0.2	0.4	0.2	0.4	0.2	0.3
90	6	0.3	0.5	0.3	0.5	0.3	0.4
	8	0.4	0.6	0.3	0.6	0.4	0.5
	2	0.2	0.3	0.2	0.3	0.2	0.2
100	4	0.3	0.4	0.3	0.4	0.3	0.3
	6	0.4	0.5	0.4	0.5	0.4	0.4
	8	0.5	0.6	0.5	0.6	0.5	0.5
112	2	0.2	0.4	0.2	0.4	0.2	0.3
	4	0.3	0.5	0.2	0.6	0.3	0.5
	6	0.4	0.7	0.3	0.8	0.4	0.6
132	8	0.5	0.8	0.4	0.9	0.5	0.7
	2	0.3	0.5	0.3	0.6	0.3	0.4
	4	0.4	0.7	0.4	0.8	0.5	0.6
160	6	0.6	0.9	0.5	1.1	0.6	0.8
	8	0.7	1.0	0.6	1.2	0.7	0.9
	2	0.4	0.9	0.3	1.1	0.5	0.8
180	4	0.6	1.2	0.5	1.4	0.6	1.1
	6	0.8	1.5	0.6	1.8	0.8	1.3
	8	0.9	1.7	0.7	2.0	0.9	1.5
200	2	1.8	1.1	1.6	1.5	2.2	0.9
	4	2.2	1.5	1.9	1.9	2.6	1.2
	6	2.5	1.8	2.2	2.3	3.1	1.5
225	8	2.9	2.2	2.5	2.7	3.4	1.8
	2	2.4	1.5	2.1	2.0	2.9	1.2
	4	2.9	2.0	2.5	2.6	3.5	1.6
250	6	3.4	2.5	3.0	3.2	4.1	2.1
	8	3.9	3.0	3.5	3.7	4.6	2.6
	2	2.7	1.7	2.2	2.4	3.4	1.2
280	4	3.3	2.3	2.8	3.1	4.1	1.8
	6	3.8	2.8	3.3	3.8	4.8	2.3
	8	4.4	3.4	3.9	4.3	5.3	2.9
315	2	3.4	2.6	2.7	3.7	4.5	1.9
	4	4.2	3.5	3.4	4.7	5.5	2.6
	6	4.8	4.0	3.8	5.7	6.5	3.0
355	8	5.7	4.9	4.8	6.4	7.1	4.1
	2	3.4	2.5	2.5	3.7	4.5	1.8
	4	3.9	3.1	2.6	5.0	5.9	1.8
355M/L	6	4.9	4.1	3.6	6.2	7.0	2.8
	8	5.8	4.9	4.5	6.8	7.6	3.8
	2	3.3	2.5	2.0	4.3	5.1	1.2
355A/B	4	4.6	3.8	2.9	6.2	7.0	2.1
	6	5.4	4.7	3.6	7.3	8.0	2.8
	8	6.1	5.4	4.2	8.2	9.0	3.4
355L	2	2.9	2.2	1.2	4.8	5.5	0.4
	4	4.7	4.0	2.2	7.9	8.6	1.4
	6	5.6	4.8	2.8	9.4	10.2	2.0
355M/L	8	6.4	5.6	3.4	10.4	11.2	2.6
	2	3.0	2.2	1.1	5.0	5.7	0.4
	4	4.5	3.7	1.4	8.2	8.9	0.6
355M/L	6	5.2	4.4	1.9	9.5	10.3	1.2
	8	6.3	5.5	3.4	10.0	10.8	2.6
	2	3.1	2.4	0.6	6.7	7.5	0.2
355M/L	4	5.5	4.7	1.9	1.1	11.6	1.2
	6	6.3	5.6	2.8	11.8	12.7	2.0
	8	7.6	6.8	3.8	13.2	13.7	2.9
355A/B	2	2.9	2.2	On request			
	4	4.6	3.9				
	6	5.2	4.5				
8	6.5	5.8					

Table 11.2 - Maximum permissible axial thrusts for ball bearings (horizontal mounting)

**Lubrication Intervals (Ambient ≤ 40°C at Rated Speed)**

Lubrication intervals (hours)			
Frame	Poles	50 Hz	60 Hz
160	2	22000	20000
	4	25000	25000
	8		
180	2	17000	14000
	4	25000	25000
	8		
200	2	15000	12000
	4	25000	25000
	8		
225	2	5000	4000
	4	14000	12000
	6	20000	17000
250	8	24000	20000
	2	5000	4000
	4	14000	12000
280	6	20000	17000
	8	24000	20000
	2	5000	4000
315	4	13000	10000
	6	18000	16000
	8	20000	20000
355	2	5000	4000
	4	11000	8000
	6	16000	13000
355	8	20000	17000
	2	5000	4000
	4	9000	6000
355	6	13000	11000
	8	19000	14000
	8	19000	14000

Table 12 - Lubrication intervals for ball bearings (horizontal mounting).  
Note: the amount of grease is indicated on the nameplate.

Lubrication intervals (hours)			
Frame	Poles	50 Hz	60 Hz
160	4	25000	25000
	6		
	8		
180	4	25000	25000
	6		
	8		
200	4	25000	21000
	6		25000
	8		
225	4	11000	9000
	6	16000	13000
	8	20000	19000
250	4	11000	9000
	6	16000	13000
	8	20000	19000
280	4	9000	7000
	6	14000	12000
	8	19000	17000
315	4	7000	5000
	6	12000	9000
	8	17000	15000
355	4	5000	4000
	6	9000	7000
	8	14000	13000

Table 13 - Lubrication intervals for roller bearings (horizontal mounting).  
Note: the amount of grease is indicated on the nameplate.

### 5.2.2 Bearing Monitoring

W22 motors can, on request, be equipped with bearing temperature detectors to provide continuous monitoring of bearing operating conditions. Most commonly used is the Pt-100 temperature detector. This type of monitoring is extremely important considering that it directly affects the grease and bearing lives particularly on motors equipped with regreasing facilities.

## 6. Mounting Forms

Motors are supplied, as standard, in the B3T foot configuration, with the terminal box on top.



Figure 25 - B3T mounting

The mounting configuration for the W22 motor lines comply with IEC 60034-7 standard. Standard mounting forms and their variations are shown in table 14. After the designation, a characteristic letter is used to define the terminal box position. So, the mounting code IM B3 can be seen in WEG documents as detailed below (without IM code).  
 B3L - terminal box on left hand side of the motor frame  
 B3T - terminal box on top of the motor frame  
 B3R - terminal box on right hand side of the motor frame

Note: The terminal box position is defined viewing the motor from the shaft end. Mounting forms and their variations are indicated in table 14.



Basic mountings	Other type of mounting				
IM B3	IM V5	IM V6	IM B6	IM B7	IM B8
IM 1001	IM 1011	IM 1031	IM 1051	IM 1061	IM 1071
IM B35	IM V15	IM V36	-*)	-*)	-*)
IM 2001	IM 2011	IM 2031	IM 2051	IM 2061	IM 2071
IM B34	IM V17	IM V37	-*)	-*)	-*)
IM 2101	IM 2111	IM 2131	IM 2151	IM 2161	IM 2171
IM B5	IM V1	IM V3	IM B30		
IM 3001	IM 3011	IM 3031			
IM B14	IM V18	IM V19			
IM 3601	IM 3611	IM 3631			

Table 14 - Mountings configurations

\*) Non-defined mountings by IEC 60034-7.

#### Important:

1. The mountings IM B34 and IM B14 with C-DIN flange, in accordance with standard EN 50347, are limited to frame size 132. As an option, C Flanges in accordance with NEMA MG 1 Part 4 standard are available for frames 63 to 355M/L.
2. For motors mounted vertically shaft down fitting of a drip cover / impact canopy is recommended to prevent ingress of small objects into the fan cover. The increase in total length of the motor with drip cover / impact canopy is shown in the section 19.
3. For motors mounted vertically with shaft up and installed in environments containing liquids, the use of a rubber slinger is recommended to prevent the ingress of liquid into the motor through the shaft.

## 7. Degree of Protection / Sealing System / Painting

### 7.1 Degree of Protection

As per IEC 60034-5, the degree of protection of a rotating electrical machine consists of the letters IP (ingress protection), followed by two characteristic numerals, with the following definitions:

- a) First characteristic numeral: refers to protection of persons against or approach to live parts and against contacts with moving parts (other than smooth rotating shafts and the like) inside the enclosure and protection of the machine against ingress of solid and foreign objects.
- b) Second characteristic numeral: protection of machines against harmful effects due to ingress of water.

As standard, W22 motors have the degree of protection IP55. According to IEC 60034-5, this defines the degree of protection as follows:

- a) First characteristic numeral 5: machine protected against dust. The enclosure is protected against contact with moving parts. Ingress of dust is not totally prevented, but dust does not enter in sufficient quantity to interfere with satisfactory operation of the machine.
- b) Second characteristic numeral 5: Machine protected against water jets. Water projected by a nozzle against the machine from any direction shall have no harmful effect.

### 7.2 Sealing System

V-Ring seals are utilized on the shafts of W22 foot mounted motors in frame sizes 63-200. For frames 225S/M to 355A/B shaft sealing is provided using the exclusive WSeal®, which consists of a double lipped V-Ring with a metallic cap (see figure 26).

This configuration operates like a labyrinth preventing ingress of water and dust into the motor.



Figure 26 - WSeal®

Alternatively, W22 motors are available with other sealing arrangements, for example, oilseal, taconite labyrinth and the WEG exclusive W3 Seal® (see Section 16 - Optional features). When fitted with a flange, the recommended seal is either a lip seal (no contact with liquid) or oilseal (direct contact with liquid).

### 7.3 Painting

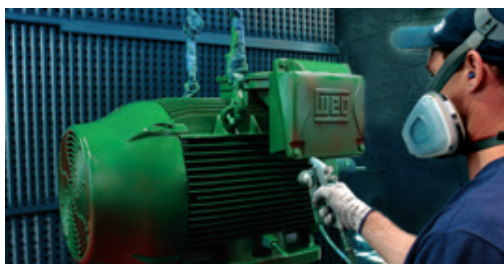

Figure 27 - WEG internal painting plan

The standard painting plans utilized on W22 motors meet the atmospheric corrosive category "C2" as indicated in the DIN EN ISO 12944-2 standard. They are designed for use on motors installed in normal environments, slightly severe, sheltered or non-sheltered, for industrial use, with low relative humidity, normal temperature variations and the presence of SO<sub>2</sub>.

Motor frame sizes 63-132 utilize WEG internal painting plan 207A (semi-matt), which consists of:

Primer: One coat of red oxide, alkyd based primer, with minimum thickness of 20 μm.

Finishing: One coat of styrenated alkyd based synthetic enamel paint, with minimum thickness of 30 μm.

And, motors in frame sizes 160-355 utilise the WEG internal paint plan 203A (semi-gloss):

Primer: One coat of red oxide, alkyd based primer, with minimum dry coat thickness of 20 μm.

Finishing: One coat of alkyd based synthetic enamel paint, with minimum dry coat thickness of 40 μm.

**Note:**

These painting plans are not recommended for direct exposure to acid steam, alkalis, solvents and salty environments.

Alternative painting plans are available on request, which are suitable to guarantee additional protection in aggressive environments, either protected or unprotected (see section 16 - Optional features).

#### 7.3.1 Tropicalized Painting

The integrity of the insulation system is the primary consideration when determining the lifetime of an electric motor. High humidity can result in premature deterioration of the insulation system, therefore for any ambient temperature with relative humidity above 95%, it is recommended to coat all internal components of the motor with an epoxy painting, also known as tropicalization.

## 8. Voltage / Frequency

As defined in IEC 60034-1 the combination of voltage and frequency variations are classified as Zone A or Zone B, as per figure 28.

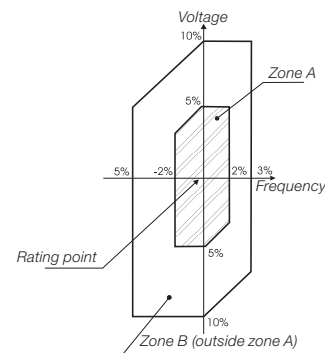

Figure 28 - Rated voltage and frequency limits for electric motors

IEC 60034-1 states that the motor must be suitable to perform its main function (supply torque) continuously within Zone A. However, this motor may not fully meet its performance characteristics due to power supply voltage and frequency variation, which can result in temperature rise above the rated value.

The motor must also be suitable to perform its main function (supply torque) at Zone B. However, the performance characteristic changes will be greater than those operating in Zone A. The temperature rise will also be higher than that at rated voltage and frequency and when operating within Zone A. Prolonged operation near the boundaries of Zone B is not recommended.

## 9. Overload Capacity

As per IEC 60034-1, motors having rated output not exceeding 315 kW and rated voltages not exceeding 1 kV shall be capable of withstanding a current equal to 1,5 times the rated current for not less than 2 min.

## 10. Ambient and Altitude

Unless otherwise specified, the rated outputs shown in the electrical data tables within this catalogue refer to continuous duty operation S1, as per IEC 60034-1 and under the following conditions:

- ambient temperature range -20 °C to +40 °C
- altitudes up to 1000 metres above sea level

For operating temperatures and altitudes differing from those above, the factors indicated in table 15 must be applied to the nominal motor power rating in order to determine the derated output (Pmax).

$$P_{max} = P_{nom} \times \text{correction factor}$$

T (°C)	Altitude (m)								
	1000	1500	2000	2500	3000	3500	4000	4500	5000
10							0.97	0.92	0.88
15						0.98	0.94	0.90	0.86
20					1.00	0.95	0.91	0.87	0.83
25				1.00	0.95	0.93	0.89	0.85	0.81
30			1.00	0.96	0.92	0.90	0.86	0.82	0.78
35		1.00	0.95	0.93	0.90	0.88	0.84	0.80	0.75
40	1.00	0.97	0.94	0.90	0.86	0.82	0.80	0.76	0.71
45	0.95	0.92	0.90	0.88	0.85	0.81	0.78	0.74	0.69
50	0.92	0.90	0.87	0.85	0.82	0.80	0.77	0.72	0.67
55	0.88	0.85	0.83	0.81	0.78	0.76	0.73	0.70	0.65
60	0.83	0.82	0.80	0.77	0.75	0.73	0.70	0.67	0.62
65	0.79	0.76	0.74	0.72	0.70	0.68	0.66	0.62	0.58
70	0.74	0.71	0.69	0.67	0.66	0.64	0.62	0.58	0.53
75	0.70	0.68	0.66	0.64	0.62	0.60	0.58	0.53	0.49
80	0.65	0.64	0.62	0.60	0.58	0.56	0.55	0.48	0.44

Table 15 - Correction factors for altitude and ambient temperature

## 11. Insulation & Temperature Rise

W22 motors are supplied with class F insulation and Class B (80 K) temperature rise at normal operating conditions (unless otherwise specified).

The difference between the temperature of the class F insulation (105 K) and the temperature rise of the design (80 K) means that, in practice, W22 motors are suitable to deliver outputs above the rated values up to a limit where the temperature rise reaches the temperature rise value of the insulation class.

The ratio between temperature rise and service factor is given by the equation below:

$$\Delta T_{FINAL} \cong (S.F.)^2 \times \Delta T_{INITIAL}$$

From the above calculation, we can conclude that the service factor is approximately 1.15. This reserve of temperature permits W22 motors with class B temperature rise (80 K) to operate continuously under the following conditions:

- Up to 15% above their rated output, considering 40 °C ambient temperature and 1000 m.a.s.l. or;
- At ambient temperatures up to 55°C or altitudes up to 3000 m.a.s.l. maintaining their nominal rated output.

**Important:** Please note that under these conditions the combined ambient and temperature rise may reach class F limits.

Table 16 shows the safety margins per thermal class.

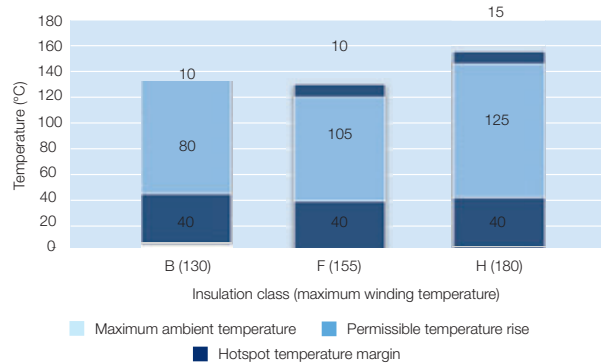

Table 16 - Safety margins per thermal class.

Bearing lubrication intervals will change under operating conditions other than 40 °C maximum ambient temperature and 1000 metres above sea level. Contact WEG for further information.

All W22 motors are wound with the WISE® insulation system which consists of enamelled wire impregnated with solvent free resin which protects motors at temperatures up to 200 °C. The WISE® system also permits motor operation with variable speed drives (see section 13).

### 11.1 Space Heaters

The use of space heaters is recommended in two situations:

- Motors installed in environments with relative air humidity up to 95%, in which the motor may remain idle for periods greater than 24 hours;
- Motors installed in environments with relative air humidity greater than 95%, regardless of the operating schedule. It should be highlighted that in this situation it is strongly recommended that an epoxy painting, more commonly known as tropicalization, is applied to the internal components of the motor. More information can be found in section 7.3.

The supply voltage for space heaters must be defined by the Customer. For all frame sizes, W22 motors can be provided with space heaters suitable for 110-127 V, 220-240 V and 380-480 V. As an option, dual voltage heaters of 110-127 / 220-240 V can be supplied for motor frame sizes 112 to 355A/B, through reconnection of the heater cables inside the terminal box.

The power rating and number of space heaters fitted depends on the size of the motor as indicated in table 17 below:

Frame	Quantities	Total power rated (W)
63 to 80	1	7.5
90 and 100	1	11
112	2	22
132 and 160	2	30
180 and 200	2	38
225 and 250	2	56
280 and 315	2	140
355	2	174

Table 17 - Power and quantity of space heaters

## 12. Motor Protections

Protections available for the W22 motor line can be classified as follows:

- Based on operating temperature
- Based on operating current

Refer to section 15 for further details of the standard and optional protection types available for W22 motors.

### 12.1 Protection Based on Operating Temperature

Continuous duty motors must be protected from overload either by a device integrated into the motor or via an independent protection system, usually a thermal relay with rated or setting current, equal to or below the value obtained when multiplying the power supply rated current ( $I_n$ ), as per table 18.

Service factor	Relay setting current
1.0 up to 1.15	$I_n \times S.F.$
$\geq 1.15$	$(I_n \times S.F.) - 5\%$

Table 18 - Relay setting current referred to service factor

#### 12.1.1 Pt-100



Figure 29 - Pt-100

These are temperature detectors with operating principle based on the properties that some materials vary the electric resistance with the variation in temperature (usually platinum, nickel or copper). They are also fitted with calibrated resistances that vary linearly with temperature, allowing continuous reading of motor operating temperature through a monitoring display, with high precision rate and response sensitivity.

The same detector can serve as alarm (with operation above the regular operating temperature) and trip (usually set up for the maximum temperature of the insulation class).

#### 12.1.2 Thermistor (PTC)



Figure 30 - Thermistor (PTC)

A thermistor is a non-linear resistance temperature detector, made from semi-conductor material. Each specific thermistor has its own unique resistance vs. temperature characteristic i.e. they have one pre-set, non-adjustable tripping point.

PTC (positive temperature coefficient) thermistors have a resistance that increases dramatically at its defined tripping temperature. This sudden variation in resistance blocks the PTC current which causes the output relay to operate and the main circuit to switch off.

Thermistors are compact, do not wear, and feature faster response times when compared to other types of thermal protectors, although they do not allow continuous monitoring of motor operating temperature.

Together with their electronic circuits, these thermistors provide full protection against overheating caused by overload, under or overvoltage or frequent reversing operations.

Where thermistor protection is required to provide both alarm and trip operation, it is necessary for each phase of the motor winding to be equipped with two sets of appropriately rated thermistors.

WEG Automation offers a range of electronic relays 'RPW' intended specifically to read the PTC signal and operate its output relay. For further information please visit the website [www.weg.net](http://www.weg.net).

#### 12.1.3 Bimetallic Thermal Protectors

These are silver-contact thermal sensors, normally closed, that operate at certain temperature rise. When their operating temperature decreases, they return to their original position instantaneously, allowing the silver contact to close again.

The bimetallic thermal protectors are series-connected with the contactor coil, and can be used either as alarm or trip.

There are also other types of thermal protectors such as Pt-1000, KTY and thermocouples. Contact your local WEG office for further information.

### 12.2 Protection Based on Operating Current

Overloads are processes which usually see the temperature increase gradually. To overcome this problem, the thermal protectors described in item 12.1 are quite suitable. However, the only way to protect motors against short-circuit currents is the application of fuses. This type of protection depends directly on the motor current and is highly effective in cases of locked rotor.

WEG Automation supplies a range of fuses in versions D and NH. Visit the website [www.weg.net](http://www.weg.net) for further information.

## 13. Variable Speed Drive Application

### 13.1 Considerations Regarding Voltage Spikes and the Insulation System

The stator windings of W22 motors are wound with class F insulation (class H optional) and are suitable for either DOL starting or via a variable speed drive. They incorporate the WEG exclusive insulation system - WISE® (WEG Insulation System Evolution) - which ensures superior electrical insulation characteristics.

The stator winding is suitable for variable speed drive application, taking into account the limits shown in table 19.

Motor rated voltage	Voltage Spikes		Rise time(*)	Time between pulses
	At motor terminals (phase-phase)	$dV/dt$ (*) At motor terminals (phase-phase)		
$V_{rated} < 460 \text{ V}$	$\leq 1600 \text{ V}$	$\leq 5200 \text{ V}/\mu\text{s}$	$\geq 0.1 \mu\text{s}$	$\geq 6 \mu\text{s}$
$460 \text{ V} \leq V_{rated} < 575 \text{ V}$	$\leq 2000 \text{ V}$	$\leq 6500 \text{ V}/\mu\text{s}$		
$575 \text{ V} \leq V_{rated} \leq 1000 \text{ V}$	$\leq 2400 \text{ V}$	$\leq 7800 \text{ V}/\mu\text{s}$		

(\*)  $dV/dt$  and Rise time definition according to Nema Std. MG1 - Part 30.

Table 19 - Supportability of random wound motors' insulation system

#### Notes:

- 1 - In order to protect the motor insulation system, the maximum recommended switching frequency is 5 kHz.
- 2 - If one or more of the above conditions is not respected, a

filter (load reactor or dV/dt filter) must be installed in the output of the VSD.

- 3 - General purpose motors with rated voltage greater than 575 V, which at the time of purchase did not have any indication of operation with VSD, are able to withstand the electrical limits set in the table above for rated voltage up to 575 V. If such conditions are not fully satisfied, output filters must be used.
- 4 - General purpose motors of the dual voltage type, for example 400/690 V or 380/660 V, which at the time of purchase were not specified for VSD operation, are permitted to be operated with the VSD at the higher voltage provided that the limits defined in the table above for rated voltage up to 460 V are fully respected. Otherwise, a load reactor or a dV/dt filter must be installed in the VSD output.

**13.2 Influence of the VSD on the Motor Temperature**

Motors operating with frequency inverters may present a higher temperature rise than when operating under sinusoidal supply. This occurs due to the combined effects of the loss increase resulting from the PWM harmonics and the reduction in ventilation experienced by self-ventilated motors when operating at low frequencies. There are basically three solutions to avoid excessive overheating of the motor in VSD applications:

- Torque derating (oversizing of the self-ventilated motor frame size);
- Forced ventilation (use of an independent cooling system);
- Optimal Flux Solution (exclusive to applications where both motor and drive are WEG).

**13.2.1 Torque Derating Criteria**

In order to maintain the temperature rise of WEG motors within acceptable levels, when supplied by VSD, the speed range-related loadability limits established in figures 31 (for operation under constant flux condition) or 32 (for operation under optimal flux condition) must be observed.

**Notes:**

- 1 - These derating curves relate to the motor thermal capability only and do not concern the insulation class. Speed regulation will depend on VSD mode of operation and proper adjustment.
- 2 - Torque derating is usually necessary when the motor is required to drive constant torque loads (e.g. screw compressors, conveyors, extruders, etc.). For squared torque loads, such as pumps and fans, no torque derating is normally required.
- 3 - W22 motors in frame sizes 90S and above can be blower cooled (independently ventilated) under request. In such cases, the motor will be suitable for VSD operation without torque derating regardless the load type.
- 4 - For operation above base (nameplate) speed, mechanical issues must be also observed. Please refer to table 20 for the maximum limits for safe operation.

**13.2.2 Constant Flux Condition**

Applicable when the motor is supplied by any commercial drive operating with any control scheme other than the Optimal Flux available in WEG drives.

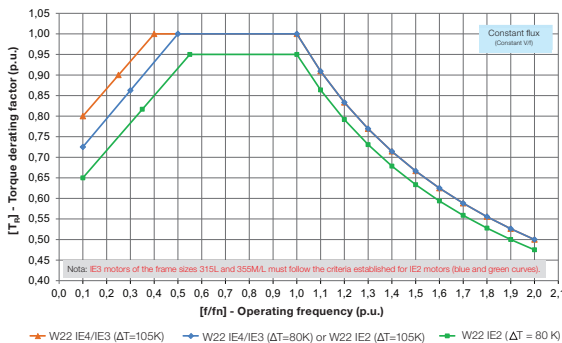

Figure 31 - Derating curves for constant flux condition

**13.2.3 Optimal Flux Condition**

The study of the composition of the overall motor losses and its relation to operation parameters such as the frequency, the magnetic flux, the current, and the speed variation led to the determination of an optimal flux value for each operating frequency. The implementation of this solution within the CFW-11 and CFW-700 control algorithms mean that the motor optimal flux condition can be automatically applied by the drive throughout the speed range, resulting in a continuous minimization of losses. As a consequence of this loss minimization, the use of the optimal flux control provides higher efficiency and lower temperature rise. Therefore, the torque derating factors for this operating condition are lower than for constant V/f, as shown in figure 32.

The optimal flux solution was developed for low frequency applications with constant torque loads. It should not be used for variable torque loads nor when the operating speed range includes points above the base (rated) frequency. The Optimal Flux Solution may be only applied under the following conditions:

- The motor has an efficiency class IE2 or above;
- The motor is controlled by a WEG drive (CFW-11 or CFW-700);
- Sensorless vector control is used.

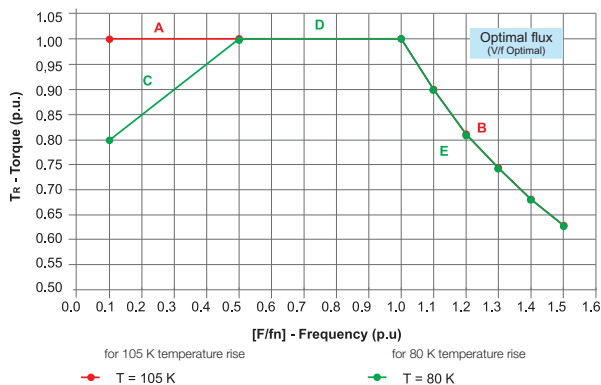

Figure 32 - Derating curves for Optimal Flux condition

kW	TEFC Motors		
	2 poles	4 poles	6 poles
0.18	7200	3600	2400
0.25	7200	3600	2400
0.37	7200	3600	2400
0.55	7200	3600	2400
0.75	7200	3600	2400
1.1	7200	3600	2400
1.5	7200	3600	2400
2.2	7200	3600	2400
4	7200	3600	2400
5.5	5400	3600	2400
7.5	5400	3600	2400
11	5400	3600	2400
15	5400	3600	2400
18.5	5400	2700	2400
22	5400	2700	2400
30	4500	2700	2400
37	4500	2700	2400
45	3600	2700	2400
55	3600	2700	2400
75	3600	2700	1800
90	3600	2700	1800
110	3600	2700	1800
150	3600	2250	1800
185	3600	2250	1800
220	3600	2250	1800
260	3600	1800	1800
300	3600	1800	-
330	3600	1800	-
370	3600	1800	-

Table 20 - Maximum safe operating speeds (rpm) for W22 motors driven by VSD

**Notes:**

- 1 - The values in table 20 are related to mechanical limitations. For operation above nameplate speed, the electrical limitations (motor torque capability) must be also observed.
- 2 - The limits established in table 20 are in accordance with the IEC 60034-1 Table 17.
- 3 - The permissible overspeed value is 10% above the limits given in Table 20 (not to exceed 2 minutes in duration) except where the maximum safe operating speed is the same as the synchronous speed at 60 Hz - in such case, please contact WEG.
- 4 - Operation above nameplate speed may require specially refined motor balancing. In such case, vibration and noise limits per IEC 60034-14 and IEC 60034-9, respectively, are not applicable.
- 5 - Bearing life will be affected by the length of time the motor is operated at various speeds.
- 6 - For speeds and ratings not covered by the table above, please contact WEG.

**13.3 Considerations Regarding Bearing Currents**

Motors for variable speed drive applications up to frame size 280S/M, do not generally require any special considerations with respects to the bearings. However, for frame sizes 315S/M upwards additional measures should be taken in order to avoid detrimental bearing currents. This can be accomplished by utilisation of an insulated bearing or insulated hub endshield and a shaft grounding brush mounted on the opposite side. W22 motors will normally be supplied duly protected per such recommendations when operation with VSD is specified at the time of purchase. Otherwise, WEG can modify motors that were not originally supplied with such protection under request.

**13.4 Forced Ventilation**

For those cases where an independent cooling system is required, W22 motors can be supplied with forced ventilation, as shown in figure 33.

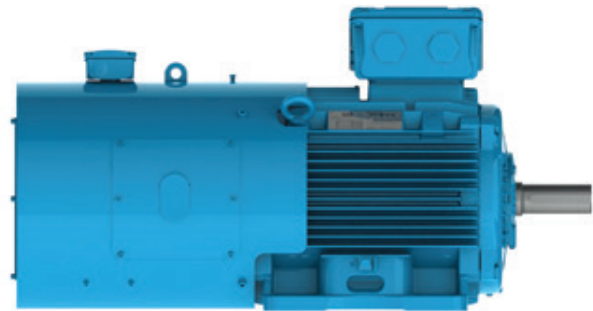

Figure 33 - Forced ventilation for W22 motors

When forced ventilation is assembled on the motor in the factory, the overall motor length will be increased, see section 20. External Motor Dimensions with Forced Ventilation. As a local stock modification option, an alternative forced ventilation kit can be fitted. Please contact your local WEG office for details of these dimensions.

**13.5 Encoders**

W22 motors may be supplied with encoders for speed control in closed loop. Encoders can be fitted to motors with either forced ventilation (TEBC) or with shaft mounted cooling fan (TEFC). When encoders are fitted, TEFC motors may not have a second shaft end or be fitted with drip cover. The following models of encoder are available for supply:

- Dynapar - B58N - 1024ppr (hollow shaft)
- Hengstler - RI58 - 1024ppr (hollow shaft)
- Leine & Linde - XH861 - 1024ppr (hollow shaft)
- Hubner Berlin - HOG 10 - 1024ppr (hollow shaft)

Other models can be supplied on request. Note: The encoders described above have 1024 pulses per revolution. Optionally, models with 2048 pulses per revolution are available.

For more information on VSD motor applications, visit our website ([www.weg.net](http://www.weg.net)) and download the Technical Guide - Induction motors Fed by PWM (code 50029350).

**14. Tolerances for Electrical Data**

The following tolerances are permissible in accordance with IEC 60034-1:

Efficiency ( $\eta$ )	-0.15 (1- $\eta$ ) for $P_{nom} \leq 150$ kW / -0.1 (1- $\eta$ ) for $P_{nom} > 150$ kW Where $\eta$ is a decimal number
Power factor	$\frac{1 - \cos \phi}{6}$ Minimum 0.02 and Maximum 0.07
Slip	$\pm 20\%$ for $P_{nom} \geq 1$ kW and $\pm 30\%$ for $P_{nom} < 1$ kW
Starting current	20% (without lower limit)
Starting torque	- 15% + 25%
Breakdown torque	- 10 %
Moment of inertia	$\pm 10$ %

Table 21 - Tolerances for electrical data

## 15. Construction Features

Frame		63	71	80	90	100	112	132	160	180	
<b>Mechanical features</b>											
<b>Mounting form</b>		B3T (options are available as per section 6)									
<b>Frame</b>	<b>Material</b>	FC-200 (EN G.JL 200) cast iron									
<b>Degree of protection</b>		IP55									
<b>Grounding</b>		Simple grounding - one earth terminal inside the terminal box									
<b>Cooling method</b>		Totally enclosed fan cooled - IC411									
<b>Fan</b>	<b>Material</b>	2P		Polypropylene							
		4 - 12P									
<b>Fan cover</b>	<b>Material</b>	Steel							FC-200 (EN G.JL 200) cast iron		
<b>Endshields</b>	<b>Material</b>	FC-200 (EN G.JL 200) cast iron									
<b>Drain hole</b>		Rubber drain plug									
<b>Bearings</b>	<b>Drive end side</b>	2p	6201-ZZ	6202-ZZ	6204-ZZ	6205-ZZ	6206-ZZ	6207-ZZ	6308-ZZ	6309-C3	6311-C3
		4 - 12p			6203-ZZ	6204-ZZ	6205-ZZ	6206-ZZ	6207-ZZ	6209-Z-C3	6211-Z-C3
	<b>Non drive end side</b>	2p								Internal bearing cap at DE with spring washer at NDE	
		4 - 12p									
<b>Locking</b>		Without bearing cap and with spring washer at NDE							Internal bearing cap at DE with spring washer at NDE		
<b>Shaft Seal</b>		'V' Ring									
<b>Lubrication</b>	<b>Type of grease</b>	Mobil Polyrex EM									
	<b>Grease fitting</b>	Without grease fitting									
<b>Terminal block</b>		BMC terminal block									
<b>Terminal box</b>	<b>Material</b>	FC-200 (EN G.JL 200) cast iron									
<b>Cable entries</b>	<b>Main</b>	<b>Size</b>	2 x M20 x 1.5		2 x M25 x 1.5		2 x M32 x 1.5		2 x M40 x 1.5		
	<b>Threaded plug</b>		Threaded plug for transport and storage; cable gland as optional								
	<b>Accessory</b>	<b>Size</b>	1 x M20 x 1.5 lateral threaded hole when fitted with accessories								
<b>Shaft</b>	<b>Material</b>		AISI 1040/45								
	<b>DE Threaded hole</b>	2p	M4	M5	M6	M8	M10	M10	M12	M16	
		4 - 12p									
<b>Direction of rotation</b>		Bidirectional									
<b>Vibration level</b>		Grade A									
<b>Nameplate</b>	<b>Material</b>	Stainless steel AISI 304									
<b>Painting</b>	<b>Type</b>	207 A							203 A		
	<b>Performance Criteria</b>	Corrosive category C2 according to DIN EN ISO 12944-2									
	<b>Colour</b>	IE2 and IE3: RAL 5009 IE4: RAL 6002									
<b>Electrical features</b>											
<b>Design</b>		N									
<b>Voltage / Frequency</b>		220-240/380-415//460 V (50 // 60Hz)					380-415/660//460 V (50 // 60Hz)				
<b>Winding</b>	<b>Impregnation</b>	Dip and bake									
	<b>Insulation class</b>	F (DT 80K)									
<b>Service factor</b>		1.00									
<b>Rotor</b>		Aluminium die cast									
<b>Thermal protection</b>		Without thermal protection							Thermistor PTC, 1 per phase, for tripping at 155 °C		



Frame		200	225S/M	250S/M	280S/M	315S/M	315L	355M/L	355A/B
<b>Mechanical features</b>									
Mounting		B3T							
Frame	Material	FC-200 (EN GJL 200) cast iron							
Degree of protection		IP55							
Grounding		Simple grounding - one earth terminal inside the terminal box	Double grounding - one earth terminal inside the terminal box and another on the motor frame						
Cooling method		Totally enclosed fan cooled - IC411							
Fan	Material	2p	Polypropylene						Aluminium
		4-12p	Polypropylene					Aluminium	
Fan cover	Material	FC-200 (EN GJL 200) cast iron							
Endshields	Material	FC-200 (EN GJL 200) cast iron							
Drain hole		Rubber drain plug							
Bearings	Drive end side	2p	6312-C3	6314-C3	6314-C3	6314-C3	6314-C3	6314-C3	6316-C3
		4-12p				6316-C3	6319-C3	6319-C3	6322-C3
	Non drive end side	2p	6212-Z-C3	6314-C3	6314-C3	6314-C3	6314-C3	6314-C3	6314-C3
		4-12p				6316-C3	6316-C3	6316-C3	6319-C3
Locking		Internal bearing cap at DE with spring washer at NDE		Locked on drive end with internal and external bearing cap and with preload springs on NDE					
Shaft Seal		'V' Ring		WSeal®					
Lubrication	Type of grease	Mobil Polyrex EM*							
	Grease fitting	Without grease fitting			With grease fitting (at DE and NDE)				
Terminal block		BMC terminal block							HGF staggered terminal block
Terminal box	Material	FC-200 (EN GJL 200) cast iron							
Cable entries	Principal	Size	2 x M50 x 1.5		2 x M63 x 1.5		2 x M63 x 1.5 (removable gland plate)	2 x M80 x 2 (removable gland plate)	
			Threaded plug						
	Accessory	Size	1 x M20 x 1.5 lateral threaded hole when fitted with accessories						
Shaft	Material		AISI 1040/45				AISI 4140		
	DE Threaded hole	2p	M20					M20	
		4-12p						M24	
Direction of rotation		Bidirectional							
Vibration level		Grade A							
Nameplate	Material	Stainless steel AISI 304							
Painting	Type	203 A							
	Performance Criteria	Corrosive category C2 according to DIN EN ISO 12944-2							
	Colour	IE2 and IE3: RAL 5009 IE4: RAL 6002							
<b>Electrical features</b>									
Design		N							
Voltage / Frequency		380-415/660//460 V (50 // 60Hz)							
Winding	Impregnation	Dip and bake			Continuous flow impregnation				
	Insulation class	F (DT 80K)							
Service factor		1.00							
Rotor		Aluminium die cast							
Thermal protection		Thermistor PTC, 1 per phase, for tripping at 155 °C							

\* Multi-voltage 50/60Hz motors are provided with Mobil Polyrex EM grease as standard. For spot wound, 2 pole, 60Hz motors in frame sizes 355M/L and 355A/B, Kluber Isoflex NBU 15 will be supplied.

## 16. Optional Features

Frame	63	71	80	90	100	112	132
<b>Mechanical optionals</b>							
<b>Terminal box</b>							
Auxiliary terminal box (thermal protection)	0	0	0	0	0	0	0
Auxiliary terminal box (heaters)	0	0	0	0	0	0	0
Terminal box with removable gland plate	NA	NA	NA	NA	NA	NA	NA
Oversized Terminal Box	NA	NA	NA	NA	NA	NA	NA
<b>Terminal block</b>							
BMC terminal block - six-pin	S	S	S	S	S	S	S
BMC terminal block - twelve-pin	NA	NA	0	0	0	0	0
HGF staggered terminal block	NA	NA	NA	NA	NA	NA	NA
<b>Cable glands</b>							
Plastic cable gland	0	0	0	0	0	0	0
Brass cable gland	0	0	0	0	0	0	0
Stainless steel cable gland	NA	NA	NA	0	0	0	0
<b>Flange</b>							
Flange FF (IEC)	0	0	0	0	0	0	0
Flange FF (IEC) - superior	0	0	0	0	0	0	0
Flange FF (IEC) - inferior	NA	0	0	0	0	0	0
Flange C-DIN (IEC)	0	0	0	0	0	0	0
Flange C-DIN (IEC) - superior	0	0	0	0	0	0	NA
Flange C-DIN (IEC) - inferior	NA	0	0	0	0	NA	0
Flange C (NEMA)	0	0	0	0	0	0	0
Flange D (NEMA)	0	0	0	0	0	0	0
Flange D (NEMA) - superior	0	0	0	0	0	0	0
Flange D (NEMA) - inferior	NA	0	0	0	0	0	0
Flange C (NEMA) - superior	0	0	0	0	0	NA	0
Flange C (NEMA) - inferior	NA	NA	NA	0	0	0	0
<b>Cooling fan</b>							
Polypropylene (2 pole)	S	S	S	S	S	S	S
Polypropylene (4 pole and above)	S	S	S	S	S	S	S
Conductive plastic (2 pole)	0	0	0	0	0	0	0
Conductive plastic (4 pole and above)	0	0	0	0	0	0	0
Aluminium (2 pole)	0	0	0	0	0	0	0
Aluminium (4 pole and above)	0	0	0	0	0	0	0
Cast iron	0	0	0	0	0	0	0
Bronze	0	0	0	0	0	0	0
<b>Bearings</b>							
ZZ ball bearings at both ends	S	S	S	S	S	S	S
2RS ball bearings at both ends	0	0	0	0	0	0	0
Without bearing cap at DE	S	S	S	S	S	S	S
With bearing cap at DE	NA	0	0	0	0	0	0
Clearance C4 (for ball bearings)	0	0	0	0	0	0	0
Roller bearing at DE	NA	NA	NA	NA	NA	NA	NA
<b>Shaft sealing</b>							
Nitrilic rubber lip seal	0	0	0	0	0	0	0
Nitrilic rubber oil seal	0	0	0	0	0	0	0
Viton lip seal	0	0	0	0	0	0	0
Viton oil seal	0	0	0	0	0	0	0
Taconite labyrinth	NA	NA	NA	0	0	0	0
W3 Seal® (brass)	NA	NA	NA	0	0	0	0
INPRO/SEAL	NA	NA	NA	0	0	0	0
<b>Other sealing</b>							
Joints sealing with Loctite 5923 (permatex)	0	0	0	0	0	0	0
Bolt sealing with Loctite 5923 (permatex)	0	0	0	0	0	0	0
<b>Degree of protection</b>							
IP56	0	0	0	0	0	0	0
IP65	0	0	0	0	0	0	0
IP66	0	0	0	0	0	0	0

Notes: Other optional features, on request.  
Some combinations of optional features are not possible - please contact WEG.

S (Standard)  
NA (Not available)  
O (Optional)

Frame	160	180	200	225S/M	250S/M	280S/M	315S/M	315L	355M/L	355A/B
<b>Mechanical optionals</b>										
<b>Terminal box</b>										
Auxiliary terminal box (thermal protection)	0	0	0	0	0	0	0	0	0	0
Auxiliary terminal box (heaters)	0	0	0	0	0	0	0	0	0	0
Terminal box with removable gland plate	0*	0*	0*	0	0	0	0	S	S	S
Oversized Terminal Box	NA	NA	NA	0	0	0	0	0	0	NA
<b>Terminal block</b>										
BMC terminal block - six-pin	S	S	S	S	S	S	S	S	S	NA
BMC terminal block - twelve-pin	0	0	0	0	0	0	0	0	0	NA
HGF staggered terminal block	NA	NA	NA	NA	NA	NA	NA	NA	NA	S
<b>Cable glands</b>										
Plastic cable gland	0	0	0	0	0	0	0	0	0	0
Brass cable gland	0	0	0	0	0	0	0	0	0	0
Stainless steel cable gland	0	0	0	0	0	0	0	0	0	0
<b>Flange</b>										
Flange FF (IEC)	0	0	0	0	0	0	0	0	0	0
Flange FF (IEC) - superior	0	0	0	NA	NA	0	NA	NA	NA	NA
Flange FF (IEC) - inferior	0	0	0	0	0	NA	0	0	NA	NA
Flange C-DIN (IEC)	NA	NA	NA	NA	NA	NA	NA	NA	NA	NA
Flange C-DIN (IEC) - superior	NA	NA	NA	NA	NA	NA	NA	NA	NA	NA
Flange C-DIN (IEC) - inferior	0	NA	NA	NA	NA	NA	NA	NA	NA	NA
Flange C (NEMA)	0	0	0	0	0	0	0	0	0	NA
Flange D (NEMA)	0	0	0	0	0	0	0	0	0	0
Flange D (NEMA) - superior	0	0	0	NA	NA	0	NA	NA	NA	NA
Flange D (NEMA) - inferior	0	0	0	0	0	NA	0	0	NA	NA
Flange C (NEMA) - superior	NA	0	0	NA	NA	0	NA	NA	NA	NA
Flange C (NEMA) - inferior	NA	NA	NA	NA	0	NA	0	0	NA	NA
<b>Cooling fan</b>										
Polypropylene (2 pole)	S	S	S	S	S	S	S	S	S	NA
Polypropylene (4 pole and above)	S	S	S	S	S	S	S	NA	NA	NA
Conductive plastic (2 pole)	0	0	0	0	0	0	0	0	0	NA
Conductive plastic (4 pole and above)	0	0	0	0	0	0	0	NA	NA	NA
Aluminium (2 pole)	0	0	0	0	0	0	0	0	0	S
Aluminium (4 pole and above)	0	0	0	0	0	0	0	S	S	S
Cast iron	0	0	0	0	0	0	0	0	0	0
Bronze	0	0	0	0	0	0	0	0	0	0
<b>Bearings</b>										
ZZ ball bearings at both ends	NA	NA	NA	NA	NA	NA	NA	NA	NA	NA
2RS ball bearings at both ends	NA	NA	NA	NA	NA	NA	NA	NA	NA	NA
Without bearing cap at DE	NA	NA	NA	NA	NA	NA	NA	NA	NA	NA
With bearing cap at DE	S	S	S	S	S	S	S	S	S	S
Clearance C4 (for ball bearings)	0	0	0	0	0	0	0	0	0	0
Roller bearing at DE	0	0	0	0	0	0	0	0	0	0
<b>Shaft sealing</b>										
Nitrilic rubber lip seal	0	0	0	0	0	0	NA	NA	NA	NA
Nitrilic rubber oil seal	0	0	0	0	0	0	NA	NA	NA	NA
Viton lip seal	0	0	0	0	0	0	0	0	0	0
Viton oil seal	0	0	0	0	0	0	0	0	0	0
Taconite labyrinth	0	0	0	0	0	0	0	0	0	0
W3 Seal® (brass)	0	0	0	0	0	0	0	0	0	0
INPRO/SEAL	0	0	0	0	0	0	0	0	0	0
<b>Other sealing</b>										
Joints sealing with Loctite 5923 (permatex)	0	0	0	0	0	0	0	0	0	0
Bolt sealing with Loctite 5923 (permatex)	0	0	0	0	0	0	0	0	0	0
<b>Degree of protection</b>										
IP56	0	0	0	0	0	0	0	0	0	0
IP65	0	0	0	0	0	0	0	0	0	0
IP66	0	0	0	0	0	0	0	0	0	0

\*Option available for motors utilizing W21 terminal box.

Frame	63	71	80	90	100	112	132
<b>Shaft</b>							
AISI 1040/45	S	S	S	S	S	S	S
AISI 4140	0	0	0	0	0	0	0
AISI 304 (stainless steel)	0	0	0	0	0	0	0
AISI 316 (stainless steel)	0	0	0	0	0	0	0
AISI 420 (stainless steel)	0	0	0	0	0	0	0
Shaft locking device (standard for roller bearing motors)	NA	NA	NA	NA	NA	NA	0
Second shaft end	0	0	0	0	0	0	0
<b>Painting plan</b>							
202P Primer: One coat with 20 to 55 µm of alkyd red oxide. Intermediate: One coat with 20 to 30 µm of isocyanate epoxy paint. Finishing: One coat with 70 to 100 µm of polyurethane paint N2677 Meets atmospheric corrosive category "C3" as indicated in DIN EN ISO 12944-2.	0	0	0	0	0	0	0
211E Primer: One coat with 100 to 140 µm of epoxy paint N2630. Finishing: One coat with 100 to 140 µm of epoxy paint N2628. Meets atmospheric corrosive categories C5 (I and M) as indicated in DIN EN ISO 12944-2.	0	0	0	0	0	0	0
211P Primer: One coat with 100 to 140 µm of epoxy paint N2630. Finishing: One coat with 70 to 100 µm of polyurethane paint N2677. Meets atmospheric corrosive categories C5 (I and M) as indicated in DIN EN ISO 12944-2.	0	0	0	0	0	0	0
212E Primer: One coat with 75 to 105 µm of epoxy paint N1277. Intermediate: One coat with 100 to 140 µm of epoxy paint N2630. Finishing: One coat with 100 to 140 µm of epoxy paint N2628. Meets atmospheric corrosive categories C5 (I and M) as indicated in DIN EN ISO 12944-2.	0	0	0	0	0	0	0
212P Primer: One coat with 75 to 105 µm of epoxy paint N1277. Intermediate: One coat with 100 to 140 µm of epoxy paint N2630. Finishing: One coat with 70 to 100 µm of polyurethane paint N2677. Meets atmospheric corrosive categories C5 (I and M) as indicated in DIN EN ISO 12944-2.	0	0	0	0	0	0	0
213E Primer: One coat with 75 to 90 µm of Silicate Ethyl paint N1661. Intermediate: One coat with 35 to 50 µm of epoxy paint N1202. Finishing: One coat with 240 to 340 µm of epoxy paint N2628. Meets atmospheric corrosive categories C5 (I and M) as indicated in DIN EN ISO 12944-2.	0	0	0	0	0	0	0
Inside of terminal box painted	0	0	0	0	0	0	0
Internal tropical protection - complete	0	0	0	0	0	0	0
<b>Grease / Lubrication</b>							
Grease - Aeroshell 7	0	0	0	0	0	0	0
Grease - Isoflex NBU-15	0	0	0	0	0	0	0
Grease - Aeroshell 22	0	0	0	0	0	0	0
Carbon steel grease nipple	NA	NA	NA	0	0	0	0
Stainless steel grease nipple	NA	NA	NA	0	0	0	0
<b>Balance and Vibration</b>							
Balance without key	0	0	0	0	0	0	0
Balance with full key	0	0	0	0	0	0	0
Vibration level grade B	0	0	0	0	0	0	0
Provision for vibration detector SPM (1 x hole M8 on DE and NDE shield for vertical reading)	NA	NA	NA	0	0	0	0
Key Type A	S	S	S	S	S	S	S
Key Type B	0	0	0	0	0	0	0
Key Type C	0	0	0	0	0	0	0
<b>Drain</b>							
Stainless steel threaded drain plug	0	0	0	0	0	0	0
"T" format threaded drain plug	0	0	0	0	0	0	0

Notes: Other optional features, on request.  
Some combinations of optional features are not possible - please contact WEG.

S (Standard)  
NA (Not available)  
O (Optional)

Frame	160	180	200	225S/M	250S/M	280S/M	315S/M	315L	355M/L	355A/B
<b>Shaft</b>										
AISI 1040/45	S	S	S	S	S	S	S	NA	NA	NA
AISI 4140	0	0	0	0	0	0	0	S	S	S
AISI 304 (stainless steel)	0	0	0	0	0	0	0	0	0	0
AISI 316 (stainless steel)	0	0	0	0	0	0	0	0	0	0
AISI 420 (stainless steel)	0	0	0	0	0	0	0	0	0	0
Shaft locking device (standard for roller bearing motors)	0	0	0	0	0	0	0	0	0	0
Second shaft end	0	0	0	0	0	0	0	0	0	0
<b>Painting plan</b>										
202P Primer: One coat with 20 to 55 µm of alkyd red oxide. Intermediate: One coat with 20 to 30 µm of isocyanate epoxy paint. Finishing: One coat with 70 to 100 µm of polyurethane paint N2677 Meets atmospheric corrosive category "C3" as indicated in DIN EN ISO 12944-2.	0	0	0	0	0	0	0	0	0	0
211E Primer: One coat with 100 to 140 µm of epoxy paint N2630. Finishing: One coat with 100 to 140 µm of epoxy paint N2628. Meets atmospheric corrosive categories C5 (I and M) as indicated in DIN EN ISO 12944-2.	0	0	0	0	0	0	0	0	0	0
211P Primer: One coat with 100 to 140 µm of epoxy paint N2630. Finishing: One coat with 70 to 100 µm of polyurethane paint N2677. Meets atmospheric corrosive categories C5 (I and M) as indicated in DIN EN ISO 12944-2.	0	0	0	0	0	0	0	0	0	0
212E Primer: One coat with 75 to 105 µm of epoxy paint N1277. Intermediate: One coat with 100 to 140 µm of epoxy paint N2630. Finishing: One coat with 100 to 140 µm of epoxy paint N2628. Meets atmospheric corrosive categories C5 (I and M) as indicated in DIN EN ISO 12944-2.	0	0	0	0	0	0	0	0	0	0
212P Primer: One coat with 75 to 105 µm of epoxy paint N1277. Intermediate: One coat with 100 to 140 µm of epoxy paint N2630. Finishing: One coat with 70 to 100 µm of polyurethane paint N2677. Meets atmospheric corrosive categories C5 (I and M) as indicated in DIN EN ISO 12944-2.	0	0	0	0	0	0	0	0	0	0
213E Primer: One coat with 75 to 90 µm of Silicate Ethyl paint N1661. Intermediate: One coat with 35 to 50 µm of epoxy paint N1202. Finishing: One coat with 240 to 340 µm of epoxy paint N2628. Meets atmospheric corrosive categories C5 (I and M) as indicated in DIN EN ISO 12944-2.	0	0	0	0	0	0	0	0	0	0
Inside of terminal box painted	0	0	0	0	0	0	0	0	0	0
Internal tropical protection - complete	0	0	0	0	0	0	0	0	0	0
<b>Grease / Lubrication</b>										
Grease - Aeroshell 7	0	0	0	0	0	0	0	0	0	0
Grease - Isoflex NBU-15	0	0	0	0	0	0	0	0	0	0
Grease - Aeroshell 22	0	0	0	0	0	0	0	0	0	0
Carbon steel grease nipple	0	0	0	S	S	S	S	S	S	S
Stainless steel grease nipple	0	0	0	0	0	0	0	0	0	0
<b>Balance and Vibration</b>										
Balance without key	0	0	0	0	0	0	0	0	0	0
Balance with full key	0	0	0	0	0	0	0	0	0	0
Vibration level grade B	0	0	0	0	0	0	0	0	0	0
Provision for vibration detector SPM (1 x hole M8 on DE and NDE shield for vertical reading)	0	0	0	0	0	0	0	0	0	0
Key Type A	S	S	S	0	0	0	0	0	0	0
Key Type B	0	0	0	S	S	S	S	S	S	S
Key Type C	0	0	0	0	0	0	0	0	0	0
<b>Drain</b>										
Stainless steel threaded drain plug	0	0	0	0	0	0	0	0	0	0
"T" format threaded drain plug	0	0	0	0	0	0	0	0	0	0

Frame	63	71	80	90	100	112	132
<b>Grounding</b>							
Double grounding (one inside terminal box and another on the motor frame)	0	0	0	0	0	0	0
Triple grounding (one inside terminal box, two on the motor frame)	NA	NA	NA	NA	NA	NA	NA
<b>Nameplates</b>							
Second main nameplate (loose)	0	0	0	0	0	0	0
Additional / Tag plate	0	0	0	0	0	0	0
VSD rating plate	0	0	0	0	0	0	0
Direction of Rotation plate	0	0	0	0	0	0	0
<b>Other mechanical optionals</b>							
Drip cover (recommended for vertical shaft down applications)	0	0	0	0	0	0	0
Rubber slinger (recommended for vertical shaft up applications)	NA	NA	NA	0	0	0	0
Stainless steel hardware	0	0	0	0	0	0	0
Grease outlet through the endshield	NA	NA	NA	0	0	0	0
Without cooling fan - IC 418 (TEAD) or IC 410 (TENV)	0	0	0	0	0	0	0
Loose leads in lieu of t/box (up to 2 metres)	0	0	0	0	0	0	0
<b>Electrical optionals</b>							
<b>Winding thermal protection</b>							
Thermostat - alarm / trip (NO or NC) - 130 °C	0	0	0	0	0	0	0
Thermostat - alarm / trip (NO or NC) - 155 °C	0	0	0	0	0	0	0
Thermostat - trip (NO or NC) - 180 °C	0	0	0	0	0	0	0
Pt-100 two wires, one per phase	0	0	0	0	0	0	0
Pt-100 two wires, two per phase	0	0	0	0	0	0	0
Pt-100 three wires, one per phase	0	0	0	0	0	0	0
Pt-100 three wires, two per phase	0	0	0	0	0	0	0
PTC Thermistor - alarm/trip (130 °C)	0	0	0	0	0	0	0
PTC Thermistor - alarm/trip (155 °C)	0	0	0	0	0	0	0
PTC Thermistor - trip (180 °C)	0	0	0	0	0	0	0
<b>Bearing thermal protection</b>							
Thermostat, one per bearing	NA	NA	NA	0	0	0	0
PTC Thermistor, one per bearing	NA	NA	NA	0	0	0	0
Pt-100 two wires, one per bearing	NA	NA	NA	0	0	0	0
Pt-100 three wires, one per bearing	NA	NA	NA	0	0	0	0
Pt-100 three wires (calibrated)	NA	NA	NA	0	0	0	0
<b>Space heaters</b>							
110-127 V	0	0	0	0	0	0	0
220-240 V	0	0	0	0	0	0	0
110-127 / 220-240 V	0	0	0	0	0	0	0
380-480 V	0	0	0	0	0	0	0
<b>Service factor</b>							
Service factor 1.15	0	0	0	0	0	0	0
<b>Insulation class</b>							
H	0	0	0	0	0	0	0
<b>Variable Speed Options</b>							
Forced ventilation kit with encoder provision (inform auxiliary motor voltage)	NA	NA	NA	0	0	0	0
Forced ventilation kit without encoder provision (inform auxiliary motor voltage)	NA	NA	NA	0	0	0	0
Encoder	NA	NA	NA	0	0	0	0
DE side shaft grounding brush	NA	NA	NA	NA	NA	NA	NA
NDE side shaft grounding brush	NA	NA	NA	NA	NA	NA	NA
Insulated DE ball bearing	NA	NA	NA	NA	NA	NA	NA
Insulated NDE ball bearing	NA	NA	NA	NA	NA	NA	NA
Insulated DE bearing hub	NA	NA	NA	NA	NA	NA	NA
Insulated NDE bearing hub	NA	NA	NA	NA	NA	NA	NA

Notes: Other optional features, on request.  
Some combinations of optional features are not allowed - then contact WEG.

S (Standard)  
NA (Not available)  
O (Optional)

Frame	160	180	200	225S/M	250S/M	280S/M	315S/M	315L	355M/L	355A/B
<b>Grounding</b>										
Double grounding (one inside terminal box and another on the motor frame)	0	0	0	S	S	S	S	S	S	S
Triple grounding (one inside terminal box, two on the motor frame)	0	0	0	0	0	0	0	0	0	0
<b>Nameplates</b>										
Second main nameplate (loose)	0	0	0	0	0	0	0	0	0	0
Additional / Tag plate	0	0	0	0	0	0	0	0	0	0
VSD rating plate	0	0	0	0	0	0	0	0	0	0
Direction of Rotation plate	0	0	0	0	0	0	0	0	0	0
<b>Other mechanical optionals</b>										
Drip cover (recommended for vertical shaft down applications)	0	0	0	0	0	0	0	0	0	0
Rubber slinger (recommended for vertical shaft up applications)	0	0	0	0	0	0	0	0	0	0
Stainless steel hardware	0	0	0	0	0	0	0	0	0	0
Grease outlet through the endshield	0	0	0	0	0	0	0	0	0	0
Without cooling fan - IC 418 (TEAO)	0	0	0	0	0	0	0	0	0	0
Loose leads in lieu of t/box (up to 2 metres)	0	0	0	0	0	0	0	0	0	0
<b>Electrical optionals</b>										
<b>Winding thermal protection</b>										
Thermostat - alarm / trip (NO or NC) - 130 °C	0	0	0	0	0	0	0	0	0	0
Thermostat - alarm / trip (NO or NC) - 155 °C	0	0	0	0	0	0	0	0	0	0
Thermostat - trip (NO or NC) - 180 °C	0	0	0	0	0	0	0	0	0	0
Pt-100 two wires, one per phase	0	0	0	0	0	0	0	0	0	0
Pt-100 two wires, two per phase	0	0	0	0	0	0	0	0	0	0
Pt-100 three wires, one per phase	0	0	0	0	0	0	0	0	0	0
Pt-100 three wires, two per phase	0	0	0	0	0	0	0	0	0	0
PTC Thermistor - alarm/trip (130 °C)	0	0	0	0	0	0	0	0	0	0
PTC Thermistor - alarm/trip (155 °C)	S	S	S	S	S	S	S	S	S	S
PTC Thermistor - trip (180 °C)	0	0	0	0	0	0	0	0	0	0
<b>Bearing thermal protection</b>										
Thermostat	0	0	0	0	0	0	0	0	0	0
PTC Thermistor	0	0	0	0	0	0	0	0	0	0
Pt-100 two wires, one per bearing	0	0	0	0	0	0	0	0	0	0
Pt-100 three wires, one per bearing	0	0	0	0	0	0	0	0	0	0
Pt-100 three wires (calibrated)	0	0	0	0	0	0	0	0	0	0
<b>Space heaters</b>										
110-127 V	0	0	0	0	0	0	0	0	0	0
220-240 V	0	0	0	0	0	0	0	0	0	0
110-127 / 220-240 V	0	0	0	0	0	0	0	0	0	0
380-480 V	0	0	0	0	0	0	0	0	0	0
<b>Service factor</b>										
Service factor 1.15	0	0	0	0	0	0	0	0	0	0
<b>Insulation class</b>										
H	0	0	0	0	0	0	0	0	0	0
<b>Variable Speed Options</b>										
Forced ventilation kit with encoder provision (inform auxiliary motor voltage)	0	0	0	0	0	0	0	0	0	0
Forced ventilation kit without encoder provision (inform auxiliary motor voltage)	0	0	0	0	0	0	0	0	0	0
Encoder	0	0	0	0	0	0	0	0	0	0
DE side shaft grounding brush	NA	NA	NA	0	0	0	0	0	0	0
NDE side shaft grounding brush	NA	NA	NA	0	0	0	0	0	0	0
Insulated DE ball bearing	NA	NA	NA	0	0	0	0	0	0	0
Insulated NDE ball bearing	NA	NA	NA	0	0	0	0	0	0	0
Insulated DE bearing hub	NA	NA	NA	0	0	0	0	0	0	0
Insulated NDE bearing hub	NA	NA	NA	0	0	0	S	S	S	S

## 17. Electrical Data

### W22 - High Efficiency - IE2 <sup>(1) (2)</sup>

Output		Frame	Full load torque (Nm)	Locked rotor current I/In	Locked rotor torque Tl/Tn	Breakdown torque Tb/Tn	Inertia J (kgm <sup>2</sup> )	Allowable locked rotor time (s)		Weight (kg)	Sound dB (A)	400 V						Full load current In (A)	
								Rated speed (rpm)	% of full load			50	75	100					
									Efficiency						Power factor				
kW	HP							Hot	Cold			50	75	100	50	75	100		
II pole - 3000 rpm - 50 Hz																			
0,12	0,16	63	0,410	4,8	3,0	2,9	0,0001	37	81	7,0	52,0	2790	53,0	60,0	61,0	0,53	0,66	0,75	0,379
0,18	0,25	63	0,620	5,3	2,3	2,4	0,0001	15	33	8,7	52,0	2790	57,0	62,0	64,0	0,57	0,70	0,79	0,510
0,25	0,33	63	0,860	5,0	2,2	2,2	0,0002	11	24	8,3	52,0	2770	58,0	63,0	65,0	0,57	0,70	0,80	0,690
0,37	0,5	71	1,25	5,8	2,5	2,6	0,0004	12	26	10,5	56,0	2830	68,0	70,0	71,0	0,60	0,75	0,84	0,895
0,55	0,75	71	1,89	5,8	2,4	2,4	0,0005	9	20	11,2	56,0	2780	70,0	72,0	74,1	0,68	0,82	0,88	1,22
0,75	1	80	2,56	6,5	2,8	2,8	0,0008	14	31	14,5	59,0	2800	76,0	78,5	79,5	0,67	0,80	0,86	1,58
1,1	1,5	80	3,75	6,5	2,8	2,8	0,0009	10	22	16,0	59,0	2800	78,0	80,0	80,0	0,67	0,79	0,85	2,33
1,5	2	90S	5,06	7,0	2,6	2,8	0,0021	7	15	20,5	64,0	2835	80,0	82,0	82,0	0,63	0,76	0,83	3,14
2,2	3	90L	7,40	6,6	3,0	3,0	0,0022	9	20	25,0	64,0	2840	83,0	83,6	83,6	0,63	0,76	0,83	4,58
3	4	100L	9,95	8,0	2,4	2,8	0,0064	7	15	35,5	67,0	2880	84,0	85,0	85,0	0,70	0,81	0,86	5,92
4	5,5	112M	13,3	7,0	2,0	2,8	0,0088	10	22	43,5	64,0	2880	86,0	86,0	86,0	0,73	0,83	0,88	7,63
5,5	7,5	132S	18,1	6,8	2,2	3,0	0,0197	17	37	68,0	68,0	2910	86,5	88,0	88,0	0,68	0,79	0,85	10,6
7,5	10	132S	24,6	6,8	2,2	2,9	0,0251	13	29	73,0	68,0	2910	88,0	88,5	88,5	0,72	0,82	0,87	14,1
9,2	12,5	132M	30,2	7,6	2,5	3,2	0,0234	10	22	76,0	68,0	2915	88,5	89,0	89,0	0,70	0,81	0,86	17,3
11	15	160M	35,8	7,0	2,3	3,0	0,0446	13	29	120	67,0	2935	90,0	90,6	90,5	0,71	0,82	0,86	20,4
15	20	160M	48,9	7,0	2,3	3,0	0,0517	9	20	130	67,0	2930	91,0	91,3	91,3	0,71	0,81	0,86	27,6
18,5	25	160L	60,1	7,4	2,4	3,1	0,0625	8	18	142	67,0	2940	91,3	92,0	92,0	0,70	0,80	0,86	33,7
22	30	180M	71,4	7,3	2,2	3,0	0,0975	9	20	164	67,0	2945	92,0	92,4	92,2	0,76	0,84	0,88	39,1
30	40	200L	97,0	6,5	2,4	2,7	0,1703	17	37	245	72,0	2955	92,5	93,0	92,9	0,75	0,83	0,87	53,6
37	50	200L	120	6,8	2,4	2,6	0,1950	16	35	270	72,0	2950	93,0	93,4	93,3	0,76	0,84	0,87	65,8
45	60	225S/M	145	7,0	2,2	2,8	0,2490	12	26	415	75,0	2960	93,3	93,6	93,6	0,79	0,86	0,89	78,0
55	75	250S/M	178	7,0	2,2	2,8	0,3736	14	31	502	75,0	2960	93,6	93,9	93,9	0,79	0,86	0,89	95,0
75	100	280S/M	241	7,0	2,0	2,8	0,8541	28	62	710	77,0	2975	93,4	94,3	94,3	0,79	0,86	0,88	130
90	125	280S/M	289	7,5	2,0	2,8	0,9386	25	55	745	77,0	2975	94,0	94,6	94,6	0,79	0,86	0,88	156
110	150	315S/M	353	7,3	2,0	2,9	1,67	24	53	1000	77,0	2980	94,3	94,9	94,9	0,79	0,86	0,89	188
132	175	315S/M	423	7,3	2,0	2,9	1,96	21	46	1050	77,0	2980	94,5	95,1	95,1	0,80	0,87	0,90	223
132	180	315S/M	423	7,3	2,0	2,9	1,96	21	46	1050	77,0	2980	94,5	95,1	95,1	0,80	0,87	0,90	223
150	200	315S/M	481	7,5	2,2	2,8	1,96	23	51	1150	77,0	2980	94,2	94,8	94,8	0,78	0,85	0,89	257
160	220	315S/M	513	7,5	2,2	2,9	2,24	23	51	1190	77,0	2980	94,8	95,3	95,3	0,80	0,87	0,90	269
185	250	315S/M	593	7,6	2,2	3,1	2,46	16	35	1250	77,0	2980	94,9	95,5	95,4	0,80	0,86	0,89	314
200	270	315L	641	7,5	2,3	2,8	2,68	21	46	1300	78,0	2980	95,0	95,5	95,4	0,82	0,88	0,90	336
220	300	315L	705	7,8	2,4	2,8	2,98	14	31	1350	78,0	2980	95,0	95,5	95,5	0,81	0,87	0,90	369
250	340	315L	802	7,8	2,4	2,8	3,42	17	37	1450	78,0	2980	95,1	95,6	95,5	0,84	0,89	0,91	415
280	380	315L	898	7,9	2,3	2,8	4,17	12	26	1600	78,0	2980	95,2	95,6	95,6	0,85	0,89	0,91	465
300	400	315L <sup>(3)</sup>	962	7,5	2,5	2,5	4,17	18	40	1640	86,0	2980	95,2	95,6	95,6	0,84	0,88	0,90	503
315	430	355M/L <sup>(4)</sup>	1008	7,8	2,1	2,6	5,60	23	51	2000	80,0	2985	95,2	95,6	95,6	0,87	0,91	0,92	517
330	450	355M/L	1056	7,0	2,4	2,4	6,03	20	44	2050	80,0	2985	95,3	95,6	95,6	0,88	0,90	0,90	554
355	480	355M/L <sup>(4)</sup>	1136	7,9	2,2	2,8	6,01	14	31	2050	80,0	2985	95,3	95,6	95,6	0,87	0,90	0,91	589
370	500	355A/B <sup>(4)</sup>	1184	7,9	2,5	2,8	6,76	40	88	2250	83,0	2985	95,6	95,9	96,2	0,85	0,89	0,90	617
400	550	355A/B <sup>(4)</sup>	1280	7,6	2,4	2,8	6,76	31	68	2400	83,0	2985	95,6	96,0	96,2	0,85	0,89	0,91	660
450	610	355A/B <sup>(4)</sup>	1440	7,5	2,5	2,7	7,40	31	68	2500	83,0	2985	95,6	96,0	96,4	0,85	0,90	0,91	740

Notes:

- (1) Efficiency values are given according to IEC 60034-2-1. They are calculated according to indirect method, with stray load losses determined by measurement.
- (2) With effect from 1st January 2017, IE2 motors placed onto the European Market and rated at 0.75 kW or above, must be used with a variable speed drive unless their design falls outside of the scope of the European Regulation or their final installation will be outside of the EU / EEA.
- (3) Motor with class F (105K) temperature rise.
- (4) Fitted with air deflector in the drive end side.



**W22 - High Efficiency - IE2 <sup>(1)</sup> <sup>(2)</sup>**

Output		380 V								415 V							
		Rated speed (rpm)	% of full load						Full load current In (A)	Rated speed (rpm)	% of full load						Full load current In (A)
			Efficiency			Power factor					Efficiency			Power factor			
kW	HP	50	75	100	50	75	100	50	75	100	50	75	100	50	75	100	
II pole - 3000 rpm - 50 Hz																	
0,12	0,16	2765	54,7	60,8	60,9	0,57	0,71	0,79	0,379	2805	51,4	59,0	60,6	0,50	0,63	0,72	0,383
0,18	0,25	2760	58,0	63,0	64,0	0,61	0,75	0,83	0,510	2805	55,0	60,9	63,6	0,53	0,66	0,76	0,514
0,25	0,33	2740	60,3	64,1	65,0	0,63	0,76	0,84	0,690	2785	55,9	61,7	64,8	0,53	0,66	0,76	0,706
0,37	0,5	2805	69,0	70,1	70,3	0,66	0,79	0,87	0,900	2845	66,9	69,7	71,2	0,57	0,72	0,82	0,882
0,55	0,75	2750	70,8	71,9	74,1	0,73	0,85	0,91	1,24	2795	68,9	71,7	74,1	0,63	0,79	0,86	1,20
0,75	1	2770	77,7	78,0	78,0	0,66	0,81	0,87	1,68	2810	75,0	78,5	79,5	0,64	0,77	0,84	1,56
1,1	1,5	2775	78,9	79,2	79,6	0,73	0,83	0,87	2,43	2815	77,1	80,2	80,2	0,62	0,75	0,82	2,33
1,5	2	2810	80,5	81,6	81,6	0,68	0,79	0,85	3,25	2850	79,3	81,9	82,5	0,58	0,73	0,81	3,08
2,2	3	2820	83,7	83,5	83,2	0,69	0,80	0,85	4,75	2855	82,2	83,4	83,9	0,59	0,72	0,80	4,56
3	4	2865	84,9	85,0	85,0	0,76	0,85	0,88	6,09	2890	83,1	84,6	85,0	0,66	0,78	0,84	5,85
4	5,5	2865	86,6	86,0	85,8	0,78	0,87	0,90	7,90	2890	85,3	85,9	86,3	0,69	0,80	0,86	7,50
5,5	7,5	2900	87,1	88,0	87,6	0,74	0,83	0,88	10,8	2915	85,6	87,6	88,0	0,63	0,76	0,83	10,5
7,5	10	2900	88,4	88,4	88,1	0,77	0,85	0,89	14,5	2915	87,3	88,3	88,7	0,67	0,79	0,85	13,8
9,2	12,5	2905	89,1	89,0	89,0	0,75	0,85	0,89	17,6	2920	87,6	88,6	89,0	0,65	0,77	0,84	17,1
11	15	2930	90,3	90,5	90,1	0,75	0,85	0,88	21,1	2940	89,6	90,5	90,6	0,67	0,79	0,84	20,1
15	20	2945	91,4	91,3	90,9	0,76	0,84	0,88	28,5	2935	90,6	91,2	91,4	0,67	0,78	0,84	27,2
18,5	25	2930	91,6	91,9	91,6	0,74	0,83	0,88	34,9	2945	91,0	91,9	92,2	0,66	0,77	0,84	33,2
22	30	2940	92,2	92,2	91,8	0,79	0,86	0,89	40,9	2950	91,8	92,4	92,4	0,73	0,82	0,87	38,1
30	40	2950	92,7	92,9	92,6	0,79	0,85	0,88	55,9	2960	92,3	93,0	93,0	0,71	0,81	0,86	52,2
37	50	2945	93,2	93,3	93,0	0,80	0,86	0,88	68,7	2955	92,8	93,4	93,5	0,73	0,82	0,86	64,0
45	60	2955	93,4	93,5	93,2	0,83	0,88	0,90	81,5	2960	93,1	93,6	93,8	0,76	0,84	0,88	75,8
55	75	2955	93,8	93,8	93,6	0,83	0,88	0,90	99,2	2960	93,3	93,8	94,0	0,75	0,84	0,88	92,5
75	100	2970	93,6	94,3	94,1	0,82	0,88	0,89	136	2975	93,2	94,2	94,3	0,76	0,84	0,87	127
90	125	2970	94,2	94,6	94,4	0,83	0,88	0,89	163	2975	93,8	94,5	94,5	0,76	0,84	0,87	152
110	150	2975	94,5	94,9	94,8	0,83	0,88	0,90	196	2980	94,1	94,8	94,9	0,76	0,84	0,88	183
132	175	2975	94,6	95,1	94,9	0,83	0,89	0,91	232	2980	94,4	95,1	95,2	0,78	0,86	0,89	217
132	180	2975	94,6	95,1	94,9	0,83	0,89	0,91	232	2980	94,4	95,1	95,2	0,78	0,86	0,89	217
150	200	2980	94,2	94,8	94,8	0,80	0,87	0,89	270	2980	93,8	94,5	94,8	0,74	0,83	0,87	253
160	220	2975	94,9	95,2	95,2	0,83	0,89	0,91	281	2980	94,7	95,3	95,3	0,78	0,86	0,89	262
185	250	2975	95,0	95,5	95,3	0,83	0,88	0,90	328	2980	94,8	95,5	95,4	0,78	0,85	0,88	307
200	270	2975	95,0	95,4	95,2	0,85	0,89	0,91	351	2980	94,9	95,5	95,5	0,80	0,87	0,90	324
220	300	2975	95,1	95,4	95,3	0,84	0,88	0,91	385	2980	94,9	95,5	95,6	0,79	0,86	0,89	360
250	340	2980	95,1	95,5	95,3	0,86	0,90	0,91	438	2980	95,0	95,6	95,6	0,82	0,88	0,91	400
280	380	2975	95,2	95,5	95,4	0,87	0,90	0,91	490	2980	95,2	95,6	95,7	0,83	0,88	0,91	447
300	400	2975	95,2	95,5	95,5	0,87	0,91	0,91	524	2980	95,5	95,7	95,7	0,83	0,87	0,90	485
315	430	2980	94,2	95,5	95,4	0,89	0,92	0,92	545	2985	95,2	95,6	95,7	0,86	0,90	0,92	498
330	450	2980	95,2	95,4	95,4	0,89	0,91	0,91	578	2985	95,3	95,6	95,7	0,87	0,89	0,89	539
355	480	2980	95,3	95,5	95,4	0,89	0,91	0,91	621	2985	95,3	95,6	95,7	0,85	0,89	0,91	567
370	500	2980	95,6	95,8	96,0	0,86	0,90	0,91	643	2985	95,3	96,0	96,3	0,84	0,88	0,89	601
400	550	2985	95,7	96,0	96,1	0,87	0,90	0,91	695	2985	95,5	96,0	96,3	0,84	0,88	0,91	635
450	610	2985	95,7	96,0	96,3	0,87	0,91	0,91	780	2985	95,5	96,0	96,5	0,84	0,89	0,91	713

## W22 - High Efficiency - IE2 <sup>(1)</sup> <sup>(2)</sup>

Output		Frame	Full load torque (Nm)	Locked rotor current I <sub>L</sub> /I <sub>n</sub>	Locked rotor torque T <sub>L</sub> /T <sub>n</sub>	Breakdown torque T <sub>b</sub> /T <sub>n</sub>	Inertia J (kgm <sup>2</sup> )	Allowable locked rotor time (s)		Weight (kg)	Sound dB (A)	Rated speed (rpm)	400 V						Full load current I <sub>n</sub> (A)	
								Hot	Cold				% of full load			Efficiency	Power factor			
													50	75	100		50	75		100
II pole - 3000 rpm - 50 Hz																				
Optional frames & high output designs																				
0,37	0,5	63	1,29	5,0	2,2	2,2	0,0002	7	15	8,9	52,0	2740	64,0	67,0	69,5	0,56	0,71	0,81	0,949	
0,75	1	71	2,59	5,8	2,8	2,8	0,0005	14	31	12,2	56,0	2770	77,0	77,5	77,6	0,67	0,80	0,87	1,60	
1,5	2	80	5,17	6,5	3,1	3,0	0,0009	15	33	17,0	59,0	2770	80,0	81,0	81,5	0,65	0,78	0,85	3,13	
3	4	L90L	10,1	7,1	3,4	3,4	0,0030	9	20	29,5	64,0	2840	84,0	84,6	84,6	0,61	0,75	0,82	6,24	
4	5,5	100L	13,3	7,8	3,0	3,4	0,0064	10	22	37,0	67,0	2870	85,2	85,8	85,8	0,67	0,80	0,86	7,82	
5,5	7,5	112M	18,3	7,3	2,7	3,0	0,0088	11	24	46,0	64,0	2880	86,5	87,0	87,0	0,72	0,82	0,87	10,5	
7,5	10	L112M	25,0	7,9	3,0	3,4	0,0109	10	22	52,5	64,0	2870	87,3	88,1	88,1	0,67	0,79	0,85	14,5	
11	15	132M	36,2	7,2	2,4	2,9	0,0270	11	24	85,0	68,0	2905	89,3	89,6	89,6	0,75	0,84	0,88	20,1	
22	30	160L	71,6	7,9	2,5	3,1	0,0813	10	22	163	67,0	2935	91,2	91,6	91,6	0,75	0,84	0,89	39,0	
30	40	180L	97,5	8,2	2,2	2,9	0,1301	8	18	215	76,0	2940	91,5	92,0	92,0	0,78	0,86	0,89	52,9	
45	60	200L	146	6,6	2,1	2,4	0,2204	15	33	290	72,0	2955	92,5	92,9	92,9	0,76	0,84	0,87	80,4	
55	75	225S/M	178	7,0	2,0	2,6	0,3238	11	24	465	75,0	2960	92,8	93,2	93,2	0,81	0,87	0,90	94,6	
75	100	250S/M	242	8,2	2,4	3,0	0,4415	10	22	530	75,0	2965	94,0	94,3	94,3	0,79	0,86	0,90	128	
110	150	280S/M	353	7,6	2,3	3,0	1,11	21	46	802	77,0	2975	94,5	94,9	94,9	0,78	0,86	0,89	188	
132	175	280S/M	424	7,3	1,8	2,7	1,33	18	40	890	77,0	2975	94,5	94,8	94,8	0,80	0,87	0,89	226	
200	270	315S/M	641	7,5	2,3	2,8	2,68	21	46	1300	77,0	2980	95,0	95,5	95,4	0,82	0,88	0,90	336	
315	430	315L <sup>(3)</sup> <sup>(4)</sup>	1010	7,9	2,3	2,7	4,17	11	24	1700	86,0	2980	95,2	95,6	95,6	0,84	0,88	0,90	528	

Notes:

(1) Efficiency values are given according to IEC 60034-2-1. They are calculated according to indirect method, with stray load losses determined by measurement.

(2) With effect from 1st January 2017, IE2 motors placed onto the European Market and rated at 0.75 kW or above, must be used with a variable speed drive unless their design falls outside of the scope of the European Regulation or their final installation will be outside of the EU / EEA.

(3) Motor with class F (105K) temperature rise.

(4) Fitted with air deflector in the drive end side.

**W22 - High Efficiency - IE2 <sup>(1)</sup>**

Output		380 V								415 V							
		Rated speed (rpm)	% of full load						Full load current In (A)	Rated speed (rpm)	% of full load						Full load current In (A)
			Efficiency			Power factor					Efficiency			Power factor			
kW	HP	50	75	100	50	75	100	50	75	100	50	75	100	50	75	100	

II pole - 3000 rpm - 50 Hz

Optional frames & high output designs

0,37	0,5	2705	65,0	67,6	69,5	0,62	0,76	0,83	0,975	2760	61,1	66,2	69,5	0,52	0,66	0,77	0,962
0,75	1	2750	77,0	77,4	77,4	0,73	0,84	0,90	1,64	2890	76,0	77,6	77,6	0,62	0,76	0,85	1,58
1,5	2	2750	81,0	81,5	81,3	0,71	0,83	0,88	3,19	2790	80,0	81,0	81,7	0,59	0,74	0,82	3,11
3	4	2830	84,5	84,5	84,6	0,67	0,79	0,85	6,34	2860	84,0	84,7	84,7	0,57	0,71	0,79	6,24
4	5,5	2860	85,5	85,8	85,8	0,73	0,83	0,88	8,05	2880	85,0	86,0	86,0	0,63	0,76	0,83	7,80
5,5	7,5	2865	87,0	86,9	87,0	0,76	0,86	0,89	10,8	2885	85,9	86,8	87,2	0,67	0,79	0,85	10,3
7,5	10	2860	87,5	88,1	88,1	0,72	0,83	0,88	14,7	2885	87,0	88,1	88,1	0,62	0,75	0,83	14,3
11	15	2895	89,7	89,5	89,6	0,79	0,87	0,89	21,0	2910	88,7	89,4	89,8	0,71	0,81	0,86	19,8
22	30	2930	91,2	91,6	91,5	0,79	0,87	0,90	40,6	2940	91,0	91,6	91,8	0,72	0,82	0,87	38,3
30	40	2935	91,5	92,0	92,0	0,81	0,88	0,90	55,0	2945	91,8	92,3	92,3	0,75	0,84	0,88	51,4
45	60	2950	92,6	92,9	92,9	0,80	0,87	0,89	82,7	2960	92,4	93,0	92,9	0,72	0,82	0,86	78,4
55	75	2955	93,0	93,2	93,2	0,83	0,89	0,91	98,5	2960	92,6	93,2	93,3	0,78	0,86	0,89	92,1
75	100	2960	94,2	94,3	94,1	0,83	0,88	0,92	132	2970	93,8	94,3	94,4	0,75	0,84	0,88	126
110	150	2970	94,7	94,9	94,8	0,82	0,88	0,90	196	2975	94,3	94,8	94,9	0,75	0,84	0,88	183
132	175	2970	94,5	94,7	94,7	0,82	0,88	0,90	235	2975	94,4	94,8	94,8	0,77	0,85	0,88	220
200	270	2975	95,0	95,4	95,2	0,85	0,89	0,91	351	2980	94,9	95,5	95,5	0,80	0,87	0,90	324
315	430	2980	94,2	95,5	95,4	0,89	0,92	0,92	545	2980	95,2	95,6	95,7	0,82	0,87	0,90	510

## W22 - High Efficiency - IE2 <sup>(1)</sup> <sup>(2)</sup>

Output		Frame	Full load torque (Nm)	Locked rotor current I <sub>L</sub> /I <sub>n</sub>	Locked rotor torque T <sub>L</sub> /T <sub>n</sub>	Breakdown torque T <sub>b</sub> /T <sub>n</sub>	Inertia J (kgm <sup>2</sup> )	Allowable locked rotor time (s)		Weight (kg)	Sound dB (A)	Rated speed (rpm)	400 V						Full load current I <sub>n</sub> (A)
								Hot	Cold				% of full load			Power factor			
													50	75	100	50	75	100	
IV pole - 1500 rpm - 50 Hz																			
0,12	0,16	63	0,830	3,9	1,8	2,0	0,0004	51	112	7,0	44,0	1380	55,0	58,0	59,1	0,54	0,67	0,77	0,381
0,18	0,25	63	1,23	4,1	2,0	2,0	0,0006	40	88	7,2	44,0	1400	53,0	59,0	64,7	0,48	0,61	0,70	0,574
0,25	0,33	71	1,71	4,5	2,0	2,2	0,0007	68	150	10,2	43,0	1400	59,0	65,0	68,5	0,49	0,62	0,71	0,742
0,37	0,5	71	2,56	4,3	2,0	2,0	0,0008	48	106	10,8	43,0	1380	63,0	68,0	72,7	0,50	0,62	0,72	1,02
0,55	0,75	80	3,64	6,0	2,3	2,8	0,0029	18	40	15,0	44,0	1445	72,0	73,8	77,1	0,55	0,68	0,75	1,37
0,75	1	80	5,08	6,0	2,6	2,6	0,0029	15	33	15,0	44,0	1410	79,0	79,6	79,8	0,63	0,76	0,81	1,63
1,1	1,5	90S	7,30	6,5	2,1	2,6	0,0049	14	31	20,8	49,0	1440	81,0	81,8	81,8	0,62	0,75	0,81	2,40
1,5	2	90L	9,95	6,3	2,0	2,8	0,0055	10	22	22,0	49,0	1440	81,5	83,0	83,0	0,57	0,71	0,80	3,26
2,2	3	100L	14,7	7,0	3,1	3,2	0,0105	11	24	34,0	53,0	1435	83,0	84,5	84,5	0,60	0,73	0,81	4,64
3	4	100L	20,2	6,5	3,2	3,3	0,0097	14	31	34,0	53,0	1420	85,0	85,6	85,6	0,63	0,75	0,82	6,17
4	5,5	112M	26,5	6,6	2,0	2,6	0,0156	13	29	43,0	56,0	1440	86,0	86,7	86,7	0,62	0,74	0,80	8,32
5,5	7,5	132S	36,0	7,3	1,9	3,0	0,0528	8	18	67,0	60,0	1460	86,5	87,3	87,7	0,68	0,80	0,86	10,5
7,5	10	132M	49,3	7,2	2,0	3,0	0,0528	8	18	68,0	60,0	1455	88,7	89,0	89,0	0,71	0,81	0,86	14,1
9,2	12,5	132M	60,4	7,7	2,2	3,2	0,0604	7	15	75,0	60,0	1455	89,2	89,5	89,5	0,69	0,80	0,85	17,3
11	15	160M	71,5	6,4	2,3	2,8	0,1048	10	22	105	61,0	1470	89,0	90,2	90,2	0,65	0,76	0,83	21,2
15	20	160L	97,8	6,2	2,3	2,8	0,1255	10	22	125	61,0	1465	90,6	91,0	91,0	0,66	0,76	0,83	28,7
18,5	25	180M	121	6,6	2,4	2,8	0,1657	14	31	164	61,0	1465	91,5	91,8	91,6	0,68	0,78	0,83	35,1
22	30	180L	143	6,8	2,6	2,9	0,2006	15	33	186	61,0	1465	92,2	92,5	92,3	0,70	0,80	0,85	40,5
30	40	200L	195	6,3	2,2	2,6	0,2929	16	35	222	65,0	1470	92,6	93,0	92,8	0,64	0,75	0,81	57,6
37	50	225S/M	240	6,6	2,2	2,7	0,4438	12	26	342	66,0	1475	93,0	93,2	93,2	0,74	0,83	0,86	66,6
45	60	225S/M	292	6,8	2,4	2,7	0,5177	10	22	363	66,0	1475	93,2	93,7	93,6	0,72	0,81	0,84	82,6
55	75	250S/M	356	6,4	2,2	2,7	0,8118	14	31	444	66,0	1475	93,6	93,9	94,0	0,75	0,84	0,87	97,1
75	100	280S/M	483	7,2	2,0	2,7	1,64	22	48	639	69,0	1485	93,8	94,4	94,4	0,74	0,83	0,86	133
90	125	280S/M	579	7,2	2,1	2,7	1,88	20	44	673	69,0	1485	94,1	94,7	94,7	0,76	0,84	0,87	158
110	150	315S/M	705	6,6	2,3	2,5	2,57	26	57	887	71,0	1490	94,3	95,0	95,0	0,74	0,83	0,86	194
132	175	315S/M	846	6,6	2,1	2,4	3,12	22	48	953	71,0	1490	94,6	95,2	95,2	0,76	0,84	0,87	230
150	200	315S/M	962	6,2	2,2	2,4	3,34	30	66	983	71,0	1490	95,0	95,4	95,4	0,77	0,84	0,87	261
160	220	315S/M	1026	6,6	2,2	2,4	3,56	20	44	1012	71,0	1490	94,8	95,4	95,4	0,77	0,84	0,87	278
185	250	315S/M	1186	6,8	2,4	2,4	3,99	18	40	1114	71,0	1490	94,9	95,6	95,6	0,75	0,83	0,86	325
200	270	315L	1283	7,0	2,4	2,6	4,43	17	37	1216	74,0	1490	95,0	95,6	95,6	0,77	0,84	0,86	351
220	300	315L	1411	7,0	2,6	2,4	4,89	14	31	1333	74,0	1490	95,2	95,7	95,7	0,76	0,84	0,87	381
250	340	315L	1603	7,0	2,6	2,4	5,44	13	29	1399	74,0	1490	95,3	95,7	95,7	0,77	0,85	0,88	428
260	350	355M/L	1667	6,8	2,1	2,4	7,73	18	40	1470	76,0	1490	95,4	95,8	95,8	0,73	0,82	0,85	461
280	380	315L	1796	7,2	2,6	2,4	6,20	12	26	1496	74,0	1490	95,4	95,8	95,8	0,76	0,84	0,87	485
300	400	355M/L	1924	7,2	2,2	2,4	8,59	18	40	1510	76,0	1490	95,5	95,8	95,8	0,74	0,82	0,85	532
315	430	355M/L	2020	7,2	2,5	2,8	8,95	14	31	1643	76,0	1490	95,5	95,8	95,8	0,72	0,81	0,84	565
330	450	355M/L	2116	6,8	2,2	2,4	9,84	17	37	1769	76,0	1490	95,5	95,8	95,8	0,73	0,81	0,84	592
355	480	355ML <sup>(4)</sup>	2277	6,9	2,4	2,3	10,7	15	33	1752	76,0	1490	95,5	95,9	95,8	0,75	0,83	0,86	622
370	500	355ML <sup>(4)</sup>	2373	7,0	2,4	2,4	11,6	15	33	1971	76,0	1490	95,5	95,9	95,8	0,75	0,83	0,86	648
400	550	355ML <sup>(4)</sup>	2565	7,8	2,6	2,4	11,6	11	24	1888	76,0	1490	95,5	95,9	95,8	0,74	0,82	0,86	701
450	610	355A/B <sup>(4)</sup>	2886	7,4	2,5	2,8	13,2	20	44	2089	76,0	1490	94,5	95,0	95,5	0,69	0,80	0,84	810
500	680	355A/B <sup>(4)</sup>	3206	7,3	2,4	2,7	14,6	17	37	2246	76,0	1490	94,5	95,0	95,5	0,72	0,81	0,85	889

Notes:

(1) Efficiency values are given according to IEC 60034-2-1. They are calculated according to indirect method, with stray load losses determined by measurement.

(2) With effect from 1st January 2017, IE2 motors placed onto the European Market and rated at 0.75 kW or above, must be used with a variable speed drive unless their design falls outside of the scope of the European Regulation or their final installation will be outside of the EU / EEA.

(3) Motor with class F (105K) temperature rise.

(4) Fitted with air deflector in the drive end side.

**W22 - High Efficiency - IE2 <sup>(1)</sup>**

Output		380 V								415 V							
		Rated speed (rpm)	% of full load						Full load current In (A)	Rated speed (rpm)	% of full load						Full load current In (A)
			Efficiency			Power factor					Efficiency			Power factor			
kW	HP	50	75	100	50	75	100	50	75	100	50	75	100	50	75	100	
IV pole - 1500 rpm - 50 Hz																	
0,12	0,16	1360	56,8	58,7	59,1	0,58	0,71	0,80	0,386	1390	53,2	57,1	59,1	0,51	0,64	0,74	0,382
0,18	0,25	1380	60,4	61,3	64,7	0,52	0,65	0,74	0,571	1380	57,7	60,6	64,7	0,48	0,58	0,68	0,569
0,25	0,33	1380	60,0	65,0	68,5	0,53	0,66	0,74	0,749	1410	57,8	64,5	68,5	0,46	0,59	0,69	0,736
0,37	0,5	1360	66,0	68,5	72,7	0,55	0,66	0,76	1,02	1390	63,0	68,0	72,7	0,46	0,58	0,69	1,03
0,55	0,75	1435	73,0	73,1	77,1	0,60	0,72	0,78	1,39	1450	70,7	73,8	77,1	0,51	0,65	0,73	1,36
0,75	1	1400	80,1	79,9	79,8	0,68	0,80	0,84	1,66	1415	77,9	79,2	80,1	0,60	0,73	0,79	1,61
1,1	1,5	1432	81,9	81,8	81,5	0,67	0,78	0,83	2,47	1444	80,1	81,5	82,1	0,58	0,72	0,79	2,36
1,5	2	1430	82,8	83,2	82,8	0,63	0,77	0,83	3,32	1445	80,1	82,3	83,1	0,53	0,68	0,78	3,22
2,2	3	1425	83,5	84,3	84,3	0,65	0,77	0,83	4,80	1440	82,3	84,5	84,9	0,56	0,71	0,79	4,56
3	4	1410	85,6	85,4	85,5	0,67	0,78	0,84	6,35	1425	84,3	85,5	86,0	0,58	0,72	0,80	6,07
4	5,5	1435	86,5	86,6	86,6	0,67	0,78	0,82	8,56	1445	85,3	86,6	87,0	0,58	0,71	0,78	8,20
5,5	7,5	1455	88,1	87,7	87,7	0,73	0,83	0,88	10,8	1460	86,5	87,3	87,7	0,65	0,77	0,84	10,4
7,5	10	1450	89,0	88,7	88,7	0,75	0,83	0,87	14,9	1460	88,3	89,0	89,4	0,67	0,78	0,84	13,9
9,2	12,5	1450	89,6	89,4	89,3	0,74	0,82	0,87	17,8	1455	88,7	89,5	89,8	0,65	0,77	0,84	16,8
11	15	1465	89,5	90,2	89,8	0,69	0,79	0,85	21,9	1470	88,5	90,0	90,3	0,61	0,73	0,81	20,9
15	20	1460	91,0	90,9	90,6	0,70	0,79	0,85	29,6	1470	90,2	90,9	91,2	0,63	0,73	0,81	28,2
18,5	25	1460	91,8	91,7	91,2	0,72	0,81	0,85	36,3	1470	91,1	91,7	91,7	0,50	0,75	0,81	34,7
22	30	1460	92,5	92,4	91,9	0,74	0,83	0,87	41,8	1465	91,8	92,4	92,4	0,66	0,77	0,83	39,9
30	40	1465	92,9	92,9	92,4	0,68	0,78	0,83	59,4	1470	92,3	92,9	92,9	0,61	0,73	0,79	56,9
37	50	1470	93,2	93,1	92,8	0,78	0,86	0,87	69,6	1475	92,7	93,1	93,3	0,70	0,81	0,85	64,9
45	60	1470	93,5	93,6	93,2	0,76	0,84	0,86	85,3	1475	92,9	93,6	93,7	0,68	0,79	0,82	81,5
55	75	1470	93,8	93,8	93,7	0,79	0,86	0,88	101	1475	93,3	93,9	94,1	0,72	0,82	0,86	94,6
75	100	1480	94,2	94,5	94,2	0,78	0,86	0,87	139	1485	93,5	94,3	94,4	0,71	0,81	0,85	130
90	125	1480	94,4	94,7	94,5	0,80	0,86	0,88	164	1485	93,8	94,6	94,7	0,73	0,82	0,86	154
110	150	1490	94,6	94,9	94,9	0,78	0,86	0,88	200	1490	93,9	94,8	95,0	0,70	0,81	0,84	192
132	175	1485	94,8	95,2	95,0	0,79	0,86	0,88	240	1490	94,4	95,1	95,2	0,73	0,82	0,86	224
150	200	1485	95,2	95,4	95,2	0,80	0,85	0,88	272	1490	94,8	95,4	95,4	0,75	0,83	0,86	254
160	220	1485	95,0	95,4	95,2	0,80	0,86	0,88	290	1490	94,6	95,3	95,4	0,74	0,82	0,86	271
185	250	1485	95,1	95,6	95,5	0,79	0,85	0,87	338	1490	94,7	95,5	95,6	0,72	0,81	0,85	317
200	270	1485	95,1	95,5	95,4	0,80	0,86	0,87	366	1490	94,8	95,6	95,7	0,74	0,82	0,85	342
220	300	1490	95,4	95,7	95,6	0,80	0,86	0,88	397	1490	95,0	95,6	95,7	0,73	0,82	0,86	372
250	340	1490	95,5	95,9	95,8	0,80	0,87	0,89	445	1490	95,1	95,8	95,9	0,74	0,83	0,87	417
260	350	1490	95,6	95,7	95,7	0,77	0,84	0,86	480	1490	94,2	95,7	95,8	0,70	0,80	0,84	449
280	380	1490	95,6	95,8	95,8	0,79	0,86	0,88	505	1490	95,2	95,7	95,8	0,73	0,82	0,86	473
300	400	1490	95,6	95,6	95,7	0,78	0,84	0,88	541	1490	95,3	95,7	95,8	0,71	0,80	0,84	519
315	430	1490	95,6	95,7	95,7	0,75	0,81	0,86	582	1490	95,3	95,7	95,8	0,69	0,79	0,83	551
330	450	1485	95,5	95,7	95,7	0,72	0,77	0,83	631	1490	95,3	95,7	95,8	0,70	0,79	0,83	577
355	480	1490	95,6	95,7	95,7	0,78	0,85	0,87	648	1490	95,4	95,8	95,8	0,72	0,81	0,85	607
370	500	1490	95,1	95,5	95,7	0,78	0,85	0,87	675	1490	95,0	95,7	95,9	0,72	0,81	0,85	631
400	550	1490	95,7	95,8	95,8	0,77	0,84	0,87	729	1490	95,3	95,8	95,8	0,71	0,80	0,85	683
450	610	1490	96,0	96,2	96,2	0,73	0,83	0,86	826	1490	94,5	95,0	95,5	0,65	0,77	0,82	799
500	680	1490	94,5	95,1	95,6	0,76	0,84	0,87	913	1490	94,5	95,0	95,5	0,69	0,79	0,84	867

## W22 - High Efficiency - IE2 <sup>(1)</sup> <sup>(2)</sup>

Output		Frame	Full load torque (Nm)	Locked rotor current I <sub>L</sub> /I <sub>n</sub>	Locked rotor torque T <sub>L</sub> /T <sub>n</sub>	Breakdown torque T <sub>b</sub> /T <sub>n</sub>	Inertia J (kgm <sup>2</sup> )	Allowable locked rotor time (s)		Weight (kg)	Sound dB (A)	Rated speed (rpm)	400 V						Full load current I <sub>n</sub> (A)
								Hot	Cold				% of full load			Power factor			
kW	HP												50	75	100	50	75	100	
IV pole - 1500 rpm - 50 Hz																			
Optional frames & high output designs																			
1,1	1,5	L80	7,51	6,6	2,6	2,8	0,0037	11	24	18,5	44,0	1400	80,5	81,4	81,4	0,66	0,79	0,84	2,32
2,2	3	L90L	14,7	7,4	2,4	2,9	0,0077	9	20	27,0	49,0	1430	83,8	84,3	84,3	0,56	0,70	0,79	4,77
5,5	7,5	L112M	36,5	7,1	2,7	3,0	0,0208	11	24	52,0	56,0	1440	87,0	87,7	87,7	0,55	0,68	0,76	11,6
7,5	10	132S	49,3	7,2	2,0	3,0	0,0528	8	18	68,0	60,0	1455	88,7	89,0	89,0	0,71	0,81	0,86	14,1
11	15	132ML <sup>(3)</sup>	72,2	7,7	2,4	3,2	0,0676	7	15	84,0	60,0	1455	89,0	89,5	89,8	0,65	0,77	0,84	21,0
18,5	25	160L	121	6,7	2,5	2,8	0,1607	9	20	140	61,0	1465	90,5	91,0	91,2	0,66	0,78	0,83	35,3
30	40	180L <sup>(3)</sup>	196	6,5	2,5	2,6	0,2393	14	31	210	61,0	1465	91,6	92,0	92,3	0,68	0,78	0,83	56,5
37	50	200L	241	6,0	2,1	2,5	0,3721	14	31	237	65,0	1470	92,8	93,0	93,0	0,70	0,80	0,83	69,2
45	60	200L <sup>(3)</sup>	293	6,5	2,3	2,6	0,3721	9	20	275	65,0	1470	92,7	93,0	93,1	0,65	0,76	0,82	85,1
55	75	225S/M	356	6,9	2,3	2,6	0,6880	15	33	420	66,0	1475	92,8	93,2	93,5	0,74	0,83	0,86	98,7
75	100	250S/M	486	7,2	2,4	2,9	1,05	10	22	496	66,0	1475	94,0	94,3	94,4	0,74	0,84	0,86	133
110	150	280S/M	708	7,6	2,4	2,6	2,27	18	40	735	69,0	1485	94,3	95,0	95,0	0,75	0,83	0,86	194
132	175	280S/M	852	6,9	2,3	2,6	2,62	17	37	785	69,0	1480	94,3	94,9	94,8	0,73	0,82	0,85	236
200	270	315S/M	1283	6,7	2,4	2,4	4,43	17	37	1216	71,0	1490	95,0	95,6	95,6	0,77	0,84	0,87	347
300	400	315L	1924	7,6	2,5	2,5	6,51	11	24	1540	78,0	1490	95,4	95,8	95,8	0,72	0,80	0,85	532
315	430	315L <sup>(3)</sup>	2020	7,6	2,5	2,5	6,51	11	24	1540	78,0	1490	95,4	95,8	95,8	0,72	0,80	0,85	558

Notes:

- (1) Efficiency values are given according to IEC 60034-2-1. They are calculated according to indirect method, with stray load losses determined by measurement.
- (2) With effect from 1st January 2017, IE2 motors placed onto the European Market and rated at 0.75 kW or above, must be used with a variable speed drive unless their design falls outside of the scope of the European Regulation or their final installation will be outside of the EU / EEA.
- (3) Motor with class F (105K) temperature rise.

**W22 - High Efficiency - IE2 <sup>(1)</sup>**

Output		380 V								415 V							
		Rated speed (rpm)	% of full load						Full load current In (A)	Rated speed (rpm)	% of full load						Full load current In (A)
			Efficiency			Power factor					Efficiency			Power factor			
kW	HP	50	75	100	50	75	100	50	75	100	50	75	100	50	75	100	

IV pole - 1500 rpm - 50 Hz

Optional frames & high output designs

1,1	1,5	1395	81,0	81,0	81,4	0,71	0,82	0,86	2,39	1410	80,0	81,0	81,4	0,62	0,75	0,83	2,27
2,2	3	1420	84,0	84,3	84,3	0,62	0,75	0,81	4,90	1440	83,4	84,4	84,4	0,53	0,67	0,75	4,84
5,5	7,5	1440	87,0	87,7	87,7	0,60	0,73	0,79	11,8	1445	86,0	87,8	87,8	0,50	0,63	0,72	11,8
7,5	10	1450	89,0	88,7	88,7	0,75	0,83	0,87	14,9	1460	88,3	89,0	89,4	0,67	0,78	0,84	13,9
11	15	1450	90,0	89,6	89,8	0,70	0,81	0,86	21,6	1460	89,0	89,5	89,8	0,60	0,74	0,81	21,0
18,5	25	1460	90,5	91,0	91,2	0,71	0,81	0,85	36,3	1470	90,0	91,0	91,2	0,62	0,75	0,81	34,8
30	40	1460	91,9	92,3	92,3	0,72	0,81	0,84	58,8	1465	91,5	92,0	92,3	0,64	0,76	0,82	55,1
37	50	1465	93,1	92,9	92,7	0,74	0,83	0,85	71,4	1472	92,5	93,0	93,2	0,67	0,78	0,81	68,2
45	60	1470	92,8	93,0	93,1	0,70	0,80	0,84	87,4	1475	92,4	92,8	93,1	0,61	0,73	0,79	85,1
55	75	1470	93,0	93,5	93,5	0,78	0,85	0,87	103	1475	92,8	93,2	93,6	0,71	0,81	0,85	96,2
75	100	1470	94,3	94,3	94,1	0,78	0,86	0,88	138	1475	93,7	94,2	94,5	0,71	0,82	0,85	130
110	150	1480	94,6	95,1	94,9	0,79	0,85	0,87	202	1485	94,0	94,9	95,0	0,72	0,81	0,85	190
132	175	1480	94,5	94,7	94,7	0,76	0,84	0,87	243	1485	94,1	94,9	94,9	0,70	0,80	0,84	230
200	270	1485	95,1	95,5	95,4	0,80	0,86	0,88	362	1490	94,8	95,6	95,7	0,74	0,82	0,86	338
300	400	1490	95,6	95,8	95,8	0,76	0,82	0,86	553	1490	95,2	95,7	95,8	0,69	0,78	0,84	519
315	430	1490	95,6	95,8	95,8	0,76	0,82	0,86	581	1490	95,2	95,7	95,8	0,69	0,78	0,84	545

## W22 - High Efficiency - IE2 <sup>(1)</sup> <sup>(2)</sup>

Output		Frame	Full load torque (Nm)	Locked rotor current I <sub>L</sub> /I <sub>n</sub>	Locked rotor torque T <sub>L</sub> /T <sub>n</sub>	Breakdown torque T <sub>b</sub> /T <sub>n</sub>	Inertia J (kgm <sup>2</sup> )	Allowable locked rotor time (s)		Weight (kg)	Sound dB (A)	Rated speed (rpm)	400 V						Full load current I <sub>n</sub> (A)
								Hot	Cold				% of full load			Power factor			
													50	75	100	50	75	100	
VI pole - 1000 rpm - 50 Hz																			
0,12	0,16	63	1,27	3,0	1,9	2,0	0,0006	52	114	7,2	43,0	905	42,0	50,0	52,0	0,43	0,53	0,63	0,529
0,18	0,25	71	1,93	3,2	2,0	2,0	0,0008	96	211	10,5	43,0	890	52,0	58,0	59,0	0,40	0,51	0,61	0,722
0,25	0,33	71	2,68	3,2	1,9	2,1	0,0008	70	154	12,5	43,0	890	53,0	60,0	61,6	0,37	0,48	0,58	1,01
0,37	0,5	80	3,88	3,9	1,8	2,0	0,0022	27	59	12,1	43,0	910	63,0	67,0	67,6	0,47	0,62	0,72	1,10
0,55	0,75	80	5,65	4,5	2,3	2,5	0,0030	21	46	14,0	43,0	930	65,0	71,0	73,1	0,50	0,62	0,72	1,51
0,75	1	90S	7,71	4,5	2,0	2,1	0,0055	23	51	19,0	45,0	930	74,5	76,0	76,0	0,51	0,64	0,73	1,95
1,1	1,5	90L	11,4	4,7	2,3	2,2	0,0066	17	37	23,0	45,0	925	76,0	78,1	78,1	0,50	0,63	0,73	2,78
1,5	2	100L	15,3	5,0	2,0	2,4	0,0110	23	51	28,5	44,0	940	79,5	80,0	80,0	0,51	0,64	0,73	3,71
2,2	3	112M	22,0	5,9	2,3	2,5	0,0257	19	42	46,0	52,0	955	81,0	82,5	83,0	0,50	0,63	0,71	5,39
3	4	132S	29,9	5,7	2,0	2,4	0,0359	31	68	57,0	53,0	960	82,5	83,6	83,6	0,50	0,63	0,71	7,30
4	5,5	132M	39,8	6,0	2,1	2,5	0,0453	21	46	68,0	53,0	960	84,0	84,8	84,8	0,51	0,64	0,72	9,46
5,5	7,5	132M	54,7	6,4	2,2	2,7	0,0604	19	42	72,0	53,0	960	85,5	86,1	86,1	0,51	0,64	0,72	12,8
7,5	10	160M	73,9	5,8	2,0	2,6	0,1229	17	37	113	56,0	970	88,3	88,7	88,3	0,64	0,76	0,82	15,0
9,2	12,5	160L	90,6	6,0	2,2	2,6	0,1492	14	31	127	56,0	970	88,5	88,9	88,6	0,64	0,76	0,82	18,3
11	15	160L	108	6,0	2,3	2,7	0,1664	13	29	136	56,0	970	89,0	89,5	89,2	0,62	0,74	0,81	22,0
15	20	180L	148	7,0	2,4	3,0	0,2565	7	15	174	56,0	970	90,3	90,5	90,3	0,70	0,81	0,86	27,9
18,5	25	200L	181	5,7	2,1	2,5	0,3517	15	33	214	60,0	975	91,0	91,4	91,2	0,67	0,77	0,82	35,7
22	30	200L	216	6,0	2,2	2,7	0,4037	14	31	225	60,0	975	91,4	91,7	91,5	0,65	0,76	0,82	42,3
30	40	225S/M	291	6,8	2,1	2,5	0,7192	12	26	359	63,0	985	92,6	92,7	92,6	0,69	0,79	0,84	55,7
37	50	250S/M	359	6,7	2,2	2,5	1,10	16	35	438	64,0	985	93,0	93,2	93,0	0,73	0,82	0,86	66,8
45	60	280S/M	437	6,2	2,0	2,5	2,02	26	57	596	65,0	985	93,4	93,6	93,4	0,68	0,78	0,82	84,8
55	75	280S/M	534	6,2	2,0	2,4	2,36	22	48	629	65,0	985	93,6	93,9	93,8	0,68	0,79	0,83	102
75	100	315S/M	724	6,2	1,9	2,2	3,83	23	51	837	67,0	990	94,0	94,3	94,2	0,69	0,79	0,83	138
90	125	315S/M	869	6,0	1,9	2,1	4,54	22	48	893	67,0	990	94,4	94,6	94,5	0,72	0,80	0,84	164
110	150	315S/M	1062	6,1	2,0	2,2	5,45	20	44	966	67,0	990	94,5	94,9	94,8	0,72	0,80	0,84	199
132	175	315S/M	1274	6,4	2,2	2,4	6,35	17	37	1036	67,0	990	94,6	95,0	95,0	0,71	0,80	0,84	239
150	200	355M/L	1440	5,6	1,8	2,0	7,41	38	84	1340	73,0	995	94,2	94,5	95,0	0,64	0,74	0,79	290
160	220	315L	1544	6,6	2,2	2,4	7,61	14	31	1228	68,0	990	94,8	95,2	95,2	0,70	0,80	0,84	289
185	250	315L	1786	6,9	2,3	2,4	8,86	12	26	1358	68,0	990	95,0	95,4	95,4	0,69	0,79	0,83	337
200	270	315L	1930	7,0	2,4	2,5	10,1	12	26	1488	68,0	990	95,1	95,4	95,4	0,69	0,79	0,83	365
220	300	315L	2123	6,8	2,3	2,3	11,0	14	31	1621	68,0	990	95,2	95,5	95,5	0,69	0,79	0,83	401
250	340	355M/L	2413	6,0	2,0	2,2	13,9	34	75	1789	73,0	990	95,3	95,5	95,5	0,66	0,76	0,81	466
260	350	355M/L	2509	6,0	2,1	2,2	12,7	34	75	1789	73,0	990	95,3	95,5	95,5	0,66	0,76	0,81	485
280	380	355M/L	2702	6,2	2,2	2,2	13,9	27	59	1884	73,0	990	95,4	95,6	95,6	0,64	0,75	0,80	528
300	400	355M/L	2895	6,2	2,2	2,2	14,3	30	66	1900	73,0	990	95,4	95,7	95,6	0,63	0,74	0,79	573
315	430	355M/L <sup>(4)</sup>	3025	6,2	2,2	2,2	15,0	28	62	1979	73,0	995	95,4	95,7	95,6	0,66	0,76	0,81	587
355	480	355A/B <sup>(4)</sup>	3426	6,2	2,0	2,3	17,1	29	64	2200	73,0	990	95,1	95,5	95,6	0,63	0,74	0,79	678
370	500	355A/B <sup>(3)(4)</sup>	3571	6,0	2,2	2,3	18,0	25	55	2300	73,0	990	95,2	95,6	95,7	0,63	0,74	0,79	706
400	550	355A/B <sup>(3)(4)</sup>	3861	6,1	2,0	2,3	18,9	29	64	2346	73,0	990	95,2	95,6	95,7	0,63	0,74	0,79	764
Optional frames & high output designs																			
4	5,5	132S	39,8	6,0	2,1	2,5	0,0453	21	46	68,0	53,0	960	84,0	84,8	84,8	0,51	0,64	0,72	9,46
37	50	225S/M	359	6,8	2,1	2,5	0,8876	11	24	390	63,0	985	93,0	93,2	93,0	0,72	0,81	0,86	66,8
45	60	250S/M	437	6,4	2,1	2,3	1,29	15	33	466	64,0	985	93,4	93,5	93,4	0,76	0,84	0,87	79,9
75	100	280S/M	724	6,4	2,0	2,4	3,03	17	37	702	65,0	990	93,9	94,3	94,2	0,69	0,79	0,84	137

Notes:

- (1) Efficiency values are given according to IEC 60034-2-1. They are calculated according to indirect method, with stray load losses determined by measurement.
- (2) With effect from 1st January 2017, IE2 motors placed onto the European Market and rated at 0.75 kW or above, must be used with a variable speed drive unless their design falls outside of the scope of the European Regulation or their final installation will be outside of the EU / EEA.
- (3) Motor with class F (105K) rise.
- (4) Fitted with air deflector in the drive end side.



**W22 - High Efficiency - IE2 <sup>(1)</sup>**

Output		380 V								415 V							
		Rated speed (rpm)	% of full load						Full load current In (A)	Rated speed (rpm)	% of full load						Full load current In (A)
			Efficiency			Power factor					Efficiency			Power factor			
kW	HP	50	75	100	50	75	100	50	75	100	50	75	100	50	75	100	
VI pole - 1000 rpm - 50 Hz																	
0,12	0,16	895	45,4	52,1	52,9	0,46	0,57	0,67	0,514	910	39,1	47,5	50,7	0,41	0,50	0,59	0,558
0,18	0,25	875	54,2	59,0	58,7	0,43	0,55	0,65	0,717	900	50,1	56,8	58,6	0,38	0,48	0,58	0,737
0,25	0,33	875	56,3	61,6	61,6	0,41	0,52	0,62	0,995	900	50,1	60,0	61,6	0,35	0,45	0,54	1,05
0,37	0,5	895	65,2	67,7	67,6	0,52	0,66	0,76	1,09	915	60,5	65,9	67,6	0,44	0,58	0,69	1,10
0,55	0,75	920	67,5	71,8	73,1	0,55	0,66	0,76	1,50	935	62,5	69,6	73,1	0,47	0,61	0,72	1,45
0,75	1	920	75,8	75,9	75,9	0,55	0,68	0,76	1,98	935	73,2	75,6	76,4	0,48	0,61	0,71	1,92
1,1	1,5	915	77,9	78,5	78,5	0,55	0,67	0,77	2,76	930	74,3	77,3	78,1	0,46	0,59	0,70	2,80
1,5	2	930	80,7	80,1	79,8	0,55	0,69	0,76	3,76	945	78,3	79,7	80,3	0,48	0,61	0,70	3,71
2,2	3	945	82,0	82,4	82,8	0,54	0,67	0,74	5,46	960	80,0	82,1	83,0	0,47	0,60	0,69	5,34
3	4	955	83,4	83,8	83,3	0,54	0,67	0,74	7,39	960	81,4	83,1	83,6	0,46	0,59	0,68	7,34
4	5,5	955	84,9	85,0	84,6	0,55	0,68	0,74	9,74	960	83,0	84,4	84,9	0,47	0,61	0,69	9,50
5,5	7,5	955	86,4	86,3	86,0	0,56	0,68	0,75	13,0	965	84,6	85,7	86,2	0,47	0,61	0,69	12,9
7,5	10	965	88,7	88,6	87,7	0,68	0,79	0,84	15,5	970	87,8	88,6	88,5	0,61	0,73	0,80	14,7
9,2	12,5	965	88,9	88,8	88,1	0,68	0,79	0,84	18,9	970	88,0	88,8	88,8	0,61	0,73	0,80	18,0
11	15	965	89,6	89,5	88,8	0,66	0,77	0,83	22,7	970	88,4	89,3	89,3	0,59	0,71	0,79	21,7
15	20	965	90,6	90,4	89,7	0,74	0,84	0,88	28,9	970	89,9	90,5	90,6	0,67	0,79	0,85	27,1
18,5	25	970	91,5	91,4	90,8	0,71	0,80	0,84	36,9	975	90,5	91,2	91,3	0,63	0,74	0,80	35,2
22	30	970	92,0	91,8	91,2	0,70	0,79	0,84	43,6	975	90,8	91,5	91,6	0,61	0,73	0,80	41,8
30	40	980	92,8	92,5	92,1	0,73	0,81	0,85	58,2	985	92,2	92,6	92,7	0,66	0,77	0,82	54,9
37	50	980	93,2	93,0	92,6	0,77	0,84	0,87	69,8	985	92,7	93,2	93,2	0,70	0,80	0,85	65,0
45	60	980	93,7	93,6	93,1	0,72	0,81	0,84	87,4	985	93,1	93,5	93,5	0,65	0,76	0,80	83,7
55	75	980	93,8	93,8	93,5	0,72	0,82	0,85	105	985	93,3	93,6	93,9	0,65	0,77	0,82	99,4
75	100	990	94,3	94,3	94,0	0,73	0,82	0,84	144	990	93,7	94,2	94,2	0,66	0,77	0,81	137
90	125	990	94,6	94,5	94,2	0,76	0,82	0,85	171	990	94,2	94,5	94,6	0,69	0,78	0,83	159
110	150	990	94,7	94,9	94,5	0,76	0,82	0,85	208	990	94,2	94,8	94,9	0,69	0,78	0,83	194
132	175	990	94,9	95,0	94,8	0,75	0,83	0,85	249	990	94,3	94,9	95,0	0,68	0,78	0,83	233
150	200	990	94,5	94,8	94,8	0,69	0,77	0,82	293	995	93,8	94,4	95,0	0,61	0,71	0,76	291
160	220	990	95,0	95,2	95,0	0,74	0,82	0,85	301	990	94,5	95,1	95,2	0,67	0,78	0,83	282
185	250	990	95,2	95,4	95,2	0,73	0,82	0,84	351	990	94,7	95,3	95,4	0,66	0,77	0,81	333
200	270	990	95,3	95,4	95,2	0,73	0,82	0,85	376	990	94,8	95,3	95,4	0,66	0,77	0,82	356
220	300	985	95,3	95,4	95,2	0,73	0,81	0,84	418	990	95,0	95,5	95,6	0,66	0,77	0,82	390
250	340	990	95,5	95,5	95,4	0,70	0,79	0,83	480	990	95,1	95,4	95,5	0,62	0,73	0,79	461
260	350	990	95,5	95,5	95,4	0,70	0,79	0,83	499	990	95,1	95,4	95,5	0,62	0,73	0,79	479
280	380	990	95,6	95,6	95,5	0,68	0,78	0,82	543	990	95,2	95,5	95,6	0,61	0,72	0,78	522
300	400	990	95,7	95,7	95,5	0,65	0,75	0,80	597	995	95,2	95,6	95,6	0,60	0,70	0,77	567
315	430	995	95,6	95,7	95,5	0,70	0,79	0,83	604	995	95,2	95,6	95,6	0,62	0,73	0,79	580
355	480	990	95,2	95,4	95,5	0,64	0,75	0,79	715	990	95,0	95,5	95,7	0,62	0,73	0,79	653
370	500	990	95,4	95,5	95,6	0,65	0,76	0,81	726	995	95,0	95,5	95,7	0,61	0,72	0,77	699
400	550	990	95,5	95,6	95,7	0,67	0,77	0,81	784	990	95,0	95,5	95,7	0,60	0,71	0,77	755
Optional frames & high output designs																	
4	5,5	955	84,9	85,0	84,6	0,55	0,68	0,74	9,74	960	83,0	84,4	84,9	0,47	0,61	0,69	9,50
37	50	980	93,1	92,9	92,4	0,76	0,83	0,87	69,9	985	92,8	93,2	93,2	0,69	0,79	0,85	65,0
45	60	980	93,4	93,2	92,8	0,79	0,86	0,88	83,7	985	93,3	93,6	93,7	0,73	0,82	0,86	77,7
75	100	985	94,1	94,2	93,9	0,73	0,82	0,85	143	990	93,7	94,2	94,3	0,66	0,77	0,83	133

## W22 - High Efficiency - IE2 <sup>(1)</sup>

Output		Frame	Full load torque (Nm)	Locked rotor current I <sub>L</sub> /I <sub>n</sub>	Locked rotor torque T <sub>L</sub> /T <sub>n</sub>	Breakdown torque T <sub>b</sub> /T <sub>n</sub>	Inertia J (kgm <sup>2</sup> )	Allowable locked rotor time (s)		Weight (kg)	Sound dB (A)	Rated speed (rpm)	400 V						Full load current I <sub>n</sub> (A)
								Hot	Cold				% of full load			Power factor			
													50	75	100	50	75	100	
VIII pole - 750 rpm - 50 Hz																			
0,12	0,16	71	1,76	2,3	1,9	2,0	0,0008	172	378	9,5	41,0	650	40,0	48,0	50,0	0,35	0,43	0,52	0,666
0,18	0,25	80	2,57	3,1	1,9	2,1	0,0024	48	106	11,5	42,0	670	47,0	53,0	55,0	0,44	0,55	0,65	0,727
0,25	0,33	80	3,57	3,2	1,9	2,1	0,0029	42	92	13,5	42,0	670	49,0	55,0	57,0	0,43	0,55	0,66	0,959
0,37	0,5	90S	4,94	3,5	2,1	2,1	0,0044	37	81	18,0	43,0	715	56,0	62,0	62,0	0,41	0,52	0,62	1,39
0,55	0,75	90L	7,67	3,5	1,9	2,0	0,0060	31	68	22,0	43,0	685	61,0	64,0	64,0	0,44	0,56	0,66	1,88
0,75	1	100L	10,1	4,6	2,0	2,4	0,0110	42	92	28,5	50,0	710	71,0	74,0	74,0	0,40	0,52	0,62	2,36
1,1	1,5	100L	14,9	4,6	2,1	2,3	0,0127	29	64	30,5	50,0	705	70,0	73,5	73,5	0,40	0,53	0,62	3,48
1,5	2	112M	20,5	4,7	2,4	2,3	0,0202	29	64	39,0	46,0	700	77,0	79,0	79,0	0,44	0,57	0,67	4,09
2,2	3	132S	30,0	5,5	2,2	2,4	0,0592	25	55	62,0	48,0	700	81,0	81,5	81,0	0,52	0,65	0,72	5,44
3	4	132M	41,0	5,5	2,3	2,4	0,0740	19	42	66,0	48,0	700	82,0	82,5	82,0	0,54	0,66	0,73	7,23
4	5,5	160M	52,7	4,7	2,0	2,2	0,1053	29	64	107	51,0	725	82,5	83,0	83,5	0,52	0,65	0,72	9,60
5,5	7,5	160M	72,5	4,7	2,0	2,2	0,1404	21	46	120	51,0	725	85,0	86,0	85,5	0,52	0,65	0,73	12,7
7,5	10	160L	98,8	4,9	2,2	2,3	0,1756	22	48	139	51,0	725	86,0	87,0	87,0	0,52	0,65	0,73	17,0
9,2	12,5	180M	121	6,0	2,0	2,5	0,2033	11	24	156	51,0	725	88,0	88,0	87,5	0,63	0,75	0,82	18,5
11	15	180L	145	6,0	2,1	2,4	0,2439	11	24	175	51,0	725	88,0	88,5	88,0	0,65	0,76	0,82	22,0
15	20	200L	196	4,4	1,8	2,0	0,4220	27	59	226	53,0	730	88,4	88,9	89,4	0,53	0,65	0,73	33,2
18,5	25	225S/M	241	6,9	2,0	2,5	0,6183	22	48	339	56,0	735	88,9	89,4	89,9	0,62	0,74	0,80	37,1
22	30	225S/M	286	6,7	2,0	2,5	0,7203	17	37	358	56,0	735	89,3	89,8	90,3	0,60	0,72	0,78	45,1
30	40	250S/M	393	7,0	2,1	2,7	1,06	17	37	433	56,0	730	90,1	90,6	91,1	0,68	0,79	0,83	57,3
37	50	280S/M	478	5,0	1,6	2,0	2,26	26	57	614	59,0	740	90,6	91,1	91,6	0,64	0,75	0,79	73,8
45	60	280S/M	581	5,4	1,7	2,0	2,71	21	46	660	59,0	740	90,8	91,3	91,8	0,64	0,75	0,79	89,6
55	75	315S/M	710	5,4	1,7	2,0	4,03	20	44	851	62,0	740	91,3	91,8	92,3	0,64	0,75	0,79	109
75	100	315S/M	968	5,3	1,6	2,0	5,31	30	66	951	62,0	740	91,5	91,9	92,4	0,66	0,76	0,80	146
90	125	315S/M	1162	5,8	1,8	2,1	6,22	26	57	1020	62,0	740	92,2	92,7	93,2	0,66	0,76	0,80	174
110	150	315L	1420	5,8	1,8	2,1	7,84	24	53	1244	68,0	740	92,5	93,0	93,5	0,64	0,75	0,80	212
132	175	315L	1704	6,2	2,0	2,2	9,30	23	51	1352	68,0	740	92,8	93,3	93,8	0,63	0,74	0,79	257
160	220	355M/L	2052	6,2	1,4	2,2	14,4	48	106	1616	70,0	745	93,1	93,6	94,1	0,62	0,74	0,79	311
185	250	355M/L	2373	6,0	1,4	2,1	16,5	46	101	1691	70,0	745	93,4	93,9	94,4	0,64	0,75	0,80	354
200	270	355M/L	2565	6,3	1,6	2,3	18,4	48	106	1765	70,0	745	93,4	93,9	94,4	0,63	0,74	0,80	382
220	300	355M/L	2822	6,6	1,9	2,3	19,9	48	106	1875	70,0	745	93,4	93,9	94,4	0,63	0,74	0,79	426
250	340	355A/B <sup>(4)</sup>	3206	6,2	1,5	2,4	21,7	47	103	2092	70,0	745	93,4	93,9	94,4	0,62	0,73	0,79	484
260	350	355A/B <sup>(4)</sup>	3335	6,2	1,5	2,4	21,7	47	103	2092	70,0	745	93,4	93,9	94,4	0,62	0,73	0,79	503
280	380	355A/B <sup>(4)</sup>	3591	7,5	2,0	2,8	25,0	44	97	2279	70,0	745	93,4	93,9	94,4	0,61	0,73	0,79	542
Optional frames & high output designs																			
37	50	250S/M	481	8,0	2,3	3,0	1,66	14	31	570	56,0	735	90,6	91,1	91,6	0,63	0,75	0,81	72,0
55	75	280S/M	710	5,4	2,0	2,0	3,16	20	44	710	59,0	740	91,3	91,8	92,3	0,64	0,75	0,79	109
110	150	315S/M	1420	5,8	1,8	2,1	7,84	24	53	1300	62,0	740	92,0	93,0	93,5	0,64	0,75	0,80	212

Note:

(1) Efficiency values are given according to IEC 60034-2-1. They are calculated according to indirect method, with stray load losses determined by measurement.

(4) Fitted with air deflector in the drive end side.

**W22 - High Efficiency - IE2 <sup>(1)</sup>**

Output		380 V								415 V							
		Rated speed (rpm)	% of full load						Full load current In (A)	Rated speed (rpm)	% of full load						Full load current In (A)
			Efficiency			Power factor					Efficiency			Power factor			
kW	HP	50	75	100	50	75	100	50	75	100	50	75	100	50	75	100	
VIII pole - 750 rpm - 50 Hz																	
0,12	0,16	635	42,9	50,1	50,8	0,37	0,47	0,56	0,641	655	37,1	45,7	48,8	0,34	0,41	0,49	0,698
0,18	0,25	660	49,3	54,4	54,9	0,47	0,59	0,69	0,722	675	45,0	51,8	54,5	0,42	0,53	0,62	0,741
0,25	0,33	660	51,1	56,2	56,8	0,47	0,59	0,70	0,955	675	47,0	53,8	56,8	0,42	0,53	0,63	0,972
0,37	0,5	710	59,5	63,8	62,4	0,44	0,56	0,67	1,34	715	53,1	59,9	60,9	0,39	0,49	0,59	1,43
0,55	0,75	675	63,3	65,1	63,5	0,47	0,61	0,70	1,88	690	58,5	62,8	63,9	0,41	0,53	0,63	1,90
0,75	1	705	73,0	75,0	73,9	0,44	0,57	0,65	2,37	715	69,2	73,0	73,7	0,38	0,49	0,59	2,40
1,1	1,5	700	72,6	73,4	73,4	0,45	0,57	0,66	3,45	705	67,8	73,0	73,0	0,37	0,49	0,59	3,55
1,5	2	695	78,8	79,6	78,5	0,49	0,61	0,70	4,15	705	75,3	78,2	78,9	0,41	0,53	0,63	4,20
2,2	3	695	81,8	81,5	79,9	0,57	0,69	0,75	5,58	705	80,1	81,4	81,4	0,49	0,62	0,70	5,37
3	4	690	82,7	82,4	80,8	0,58	0,70	0,75	7,52	705	81,1	82,4	82,5	0,50	0,63	0,71	7,13
4	5,5	720	82,5	83,0	83,5	0,56	0,68	0,74	9,84	730	82,5	83,0	83,5	0,49	0,62	0,70	9,52
5,5	7,5	720	85,8	86,0	84,9	0,56	0,68	0,75	13,1	725	84,2	85,7	85,7	0,49	0,62	0,71	12,6
7,5	10	720	86,8	87,2	86,6	0,56	0,69	0,76	17,3	725	85,1	86,7	87,1	0,49	0,62	0,71	16,9
9,2	12,5	720	88,5	87,9	86,8	0,67	0,78	0,84	19,2	725	87,4	87,9	87,8	0,59	0,72	0,80	18,2
11	15	720	88,4	88,3	87,2	0,70	0,79	0,84	22,8	725	87,5	88,5	88,4	0,64	0,75	0,81	21,4
15	20	730	88,2	88,7	89,2	0,58	0,70	0,76	33,6	735	88,7	89,2	89,7	0,49	0,62	0,70	33,2
18,5	25	735	88,7	89,2	89,7	0,67	0,77	0,82	38,2	740	89,2	89,7	90,2	0,58	0,71	0,77	37,1
22	30	735	89,0	89,5	90,0	0,65	0,76	0,81	45,9	735	89,6	90,1	90,6	0,55	0,68	0,76	44,5
30	40	730	89,9	90,4	90,9	0,70	0,80	0,84	59,7	735	90,4	90,9	91,4	0,62	0,74	0,80	57,1
37	50	735	90,4	90,9	91,4	0,69	0,78	0,81	75,9	740	90,4	91,4	91,9	0,60	0,72	0,77	72,7
45	60	735	90,6	91,1	91,6	0,69	0,78	0,81	92,1	740	91,1	91,6	92,1	0,60	0,72	0,77	88,3
55	75	735	91,1	91,6	92,1	0,68	0,78	0,80	113	740	91,6	92,1	92,6	0,60	0,72	0,77	107
75	100	735	91,3	91,7	92,1	0,70	0,79	0,81	153	740	91,6	92,1	92,6	0,63	0,74	0,79	143
90	125	740	92,0	92,5	93,0	0,70	0,79	0,81	182	740	92,5	93,0	93,5	0,62	0,73	0,78	172
110	150	740	92,3	92,8	93,3	0,69	0,78	0,82	218	740	92,8	93,3	93,8	0,60	0,72	0,78	209
132	175	740	92,6	93,1	93,6	0,68	0,77	0,81	265	740	93,1	93,6	94,1	0,59	0,71	0,77	253
160	220	745	92,9	93,4	93,9	0,67	0,78	0,81	320	745	93,4	93,9	94,4	0,58	0,71	0,77	306
185	250	745	93,2	93,7	94,2	0,69	0,78	0,82	364	745	93,7	94,2	94,7	0,60	0,72	0,78	348
200	270	745	93,2	93,7	94,2	0,68	0,78	0,83	389	745	93,7	94,2	94,7	0,59	0,71	0,78	377
220	300	745	93,2	93,7	94,2	0,68	0,78	0,81	438	745	93,7	94,2	94,7	0,59	0,71	0,77	420
250	340	745	93,2	93,7	94,2	0,67	0,77	0,81	498	745	93,7	94,2	94,7	0,58	0,70	0,77	477
260	350	745	93,2	93,7	94,2	0,67	0,77	0,81	518	745	93,7	94,2	94,7	0,58	0,70	0,77	496
280	380	745	93,2	93,7	94,2	0,66	0,76	0,81	558	745	93,7	94,2	94,7	0,57	0,70	0,77	534
Optional frames & high output designs																	
37	50	730	90,3	90,8	91,3	0,68	0,78	0,83	74,2	735	90,9	91,4	91,9	0,60	0,73	0,79	70,9
55	75	735	91,1	91,6	92,1	0,68	0,78	0,80	113	740	91,6	92,1	92,6	0,60	0,72	0,77	107
110	150	740	92,3	92,8	93,3	0,69	0,78	0,82	218	740	92,8	93,3	93,8	0,60	0,72	0,78	209

### W22 - Premium Efficiency - IE3 <sup>(1)</sup>

Output		Frame	Full load torque (Nm)	Locked rotor current I <sub>L</sub> /I <sub>n</sub>	Locked rotor torque T <sub>L</sub> /T <sub>n</sub>	Breakdown torque T <sub>b</sub> /T <sub>n</sub>	Inertia J (kgm <sup>2</sup> )	Allowable locked rotor time (s)		Weight (kg)	Sound dB (A)	Rated speed (rpm)	400 V						Full load current I <sub>n</sub> (A)
								Hot	Cold				% of full load			Power factor			
													50	75	100	50	75	100	
II pole - 3000 rpm - 50 Hz																			
0,12	0,16	63	0,410	5,4	3,1	3,3	0,0001	30	66	6,9	52,0	2820	58,0	60,8	60,8	0,54	0,67	0,76	0,375
0,18	0,25	63	0,610	5,2	3,0	3,2	0,0002	22	48	8,0	52,0	2815	61,0	65,9	65,9	0,53	0,65	0,74	0,533
0,25	0,33	63	0,850	5,5	3,2	3,2	0,0002	17	37	7,9	52,0	2805	63,0	68,0	69,7	0,54	0,68	0,77	0,672
0,37	0,5	71	1,25	6,0	2,5	2,5	0,0004	12	26	10,5	56,0	2820	73,0	73,8	73,8	0,66	0,79	0,85	0,851
0,55	0,75	71	1,90	5,9	3,0	3,0	0,0005	18	40	11,0	56,0	2770	75,0	76,0	77,8	0,68	0,81	0,86	1,19
0,75	1	80	2,54	7,5	3,5	3,5	0,0008	25	55	14,1	59,0	2825	80,0	82,0	81,0	0,63	0,76	0,82	1,63
1,1	1,5	80	3,71	7,4	3,6	3,6	0,0009	23	51	15,0	59,0	2830	81,0	83,5	83,0	0,63	0,76	0,82	2,33
1,5	2	90S	4,99	7,6	3,3	3,3	0,0020	15	33	21,5	62,0	2875	83,0	85,0	84,5	0,64	0,76	0,83	3,09
2,2	3	90L	7,32	7,5	3,4	3,5	0,0026	12	26	24,5	62,0	2870	86,0	86,5	86,3	0,65	0,77	0,83	4,43
3	4	100L	9,85	8,5	3,4	3,4	0,0064	15	33	35,0	67,0	2910	85,5	87,3	87,3	0,69	0,81	0,86	5,77
4	5,5	112M	13,2	7,7	2,9	3,5	0,0081	22	48	41,0	64,0	2900	88,0	88,4	88,4	0,69	0,80	0,86	7,59
5,5	7,5	132S	17,9	7,9	2,4	3,5	0,0180	16	35	62,0	67,0	2930	86,9	88,7	89,4	0,66	0,78	0,84	10,6
7,5	10	132S	24,5	8,8	2,7	3,6	0,0234	10	22	70,0	67,0	2930	88,5	89,8	90,3	0,68	0,80	0,85	14,1
9,2	12,5	132M	30,0	8,5	2,9	3,3	0,0303	16	35	84,0	67,0	2930	90,4	91,1	90,7	0,75	0,84	0,88	16,6
11	15	160M	35,7	8,0	2,6	3,4	0,0482	12	26	115	67,0	2945	90,3	91,4	91,4	0,71	0,82	0,87	20,0
15	20	160M	48,7	8,3	2,8	3,5	0,0551	8	18	120	67,0	2945	90,9	91,8	92,1	0,67	0,79	0,85	27,7
18,5	25	160L	60,0	8,6	3,1	3,7	0,0663	6	13	135	67,0	2945	91,5	92,3	92,6	0,69	0,80	0,85	33,9
22	30	180M	71,3	8,3	2,7	3,6	0,0968	6	13	170	67,0	2950	92,3	93,0	92,9	0,69	0,80	0,86	39,7
30	40	200L	96,8	7,7	3,0	3,0	0,1703	16	35	235	72,0	2960	92,2	93,2	93,5	0,69	0,80	0,85	54,5
37	50	200L	119	7,7	3,1	3,0	0,1881	13	29	250	72,0	2960	92,6	93,4	93,8	0,69	0,79	0,84	67,8
45	60	225S/M	145	7,7	2,4	3,1	0,2861	13	29	380	74,0	2960	94,2	94,5	94,2	0,78	0,86	0,89	77,5
55	75	250S/M	178	7,8	2,7	3,3	0,3736	19	42	460	74,0	2960	93,6	94,4	94,4	0,77	0,85	0,88	95,6
75	100	280S/M	241	7,5	2,0	3,1	0,9386	36	79	680	77,0	2975	93,7	94,8	94,9	0,78	0,85	0,88	130
90	125	280S/M	289	7,6	2,1	3,1	1,12	27	59	710	77,0	2975	94,3	95,2	95,2	0,81	0,87	0,89	153
110	150	315S/M	353	7,5	1,9	3,0	1,66	38	84	900	77,0	2980	94,3	95,3	95,4	0,78	0,85	0,88	189
132	175	315S/M	423	7,6	2,1	3,1	1,96	34	75	950	77,0	2980	94,5	95,4	95,6	0,78	0,86	0,89	224
150	200	315S/M	481	7,5	2,3	3,1	2,18	20	44	1050	77,0	2980	95,0	95,6	95,6	0,80	0,86	0,89	254
160	220	315S/M	513	7,4	2,0	2,9	2,24	28	62	1080	77,0	2980	95,1	95,8	95,8	0,79	0,86	0,89	271
185	250	315S/M	593	7,6	2,3	3,1	2,46	22	48	1110	77,0	2980	95,4	95,8	95,8	0,79	0,86	0,89	313
200	270	315L	642	7,6	2,3	2,9	2,68	23	51	1200	78,0	2975	95,7	96,2	96,0	0,82	0,88	0,90	334
220	300	315L	705	8,5	2,7	3,3	3,13	23	51	1320	78,0	2980	95,9	96,0	96,0	0,81	0,88	0,90	368
250	340	315L	802	7,8	2,7	2,9	3,57	21	46	1350	78,0	2980	96,3	96,0	96,0	0,85	0,90	0,91	413
260	350	315L	834	7,8	2,7	2,9	3,57	21	46	1370	78,0	2980	96,3	96,7	96,0	0,85	0,90	0,91	430
280	380	315L	896	7,5	2,5	2,7	4,17	22	48	1550	78,0	2985	95,4	95,8	96,0	0,84	0,89	0,91	463
315	430	355ML <sup>(4)</sup>	1010	7,7	2,1	2,5	6,01	23	51	1950	80,0	2980	95,5	96,0	96,0	0,87	0,90	0,91	520
330	450	355ML	1058	7,7	2,3	2,5	6,01	28	62	1950	80,0	2980	95,2	95,8	96,0	0,87	0,90	0,91	545
355	480	355ML <sup>(4)</sup>	1136	7,9	2,2	2,8	6,01	14	31	1950	80,0	2985	95,3	95,6	95,8	0,87	0,90	0,91	588
370	500	355AB <sup>(4)</sup>	1184	7,9	2,5	2,8	6,76	40	88	2046	83,0	2985	95,8	96,1	96,4	0,85	0,89	0,90	616
400	550	355AB <sup>(4)</sup>	1280	7,6	2,4	2,8	6,76	31	68	2250	83,0	2985	95,8	96,2	96,4	0,85	0,89	0,91	658
450	610	355AB <sup>(4)</sup>	1440	7,5	2,5	2,7	7,40	31	68	2400	83,0	2985	95,8	96,2	96,4	0,85	0,90	0,91	740
Optional frames & high output designs																			
11	15	132M	35,9	8,2	2,7	3,0	0,0303	11	24	84,0	67,0	2925	90,6	91,1	91,2	0,75	0,85	0,89	19,6
75	100	250S/M	242	7,6	3,0	2,8	0,5132	11	24	500	74,0	2965	95,0	95,3	94,9	0,83	0,87	0,89	128
110	150	280S/M	353	7,5	2,1	3,0	1,33	20	44	790	77,0	2975	95,0	95,5	95,4	0,80	0,87	0,89	187
200	270	315S/M	642	7,6	2,3	2,9	2,68	23	51	1200	77,0	2975	95,7	96,2	96,0	0,82	0,88	0,90	334

Note:

(1) Efficiency values are given according to IEC 60034-2-1. They are calculated according to indirect method, with stray load losses determined by measurement.

(4) Fitted with air deflector in the drive end side.

**W22 - Premium Efficiency - IE3 <sup>(1)</sup>**

Output		380 V								415 V							
		Rated speed (rpm)	% of full load						Full load current In (A)	Rated speed (rpm)	% of full load						Full load current In (A)
			Efficiency			Power factor					Efficiency			Power factor			
kW	HP	50	75	100	50	75	100	50	75	100	50	75	100	50	75	100	
II pole - 3000 rpm - 50 Hz																	
0,12	0,16	2795	59,0	60,8	60,8	0,58	0,71	0,79	0,380	2835	57,0	60,8	60,8	0,51	0,64	0,73	0,376
0,18	0,25	2790	62,6	65,9	65,9	0,57	0,70	0,79	0,525	2825	59,6	65,2	65,9	0,49	0,62	0,71	0,535
0,25	0,33	2780	64,6	68,7	69,7	0,59	0,73	0,81	0,673	2820	61,5	67,2	69,7	0,51	0,64	0,74	0,674
0,37	0,5	2795	73,6	74,3	73,8	0,71	0,82	0,87	0,876	2825	72,4	73,8	73,8	0,63	0,76	0,83	0,840
0,55	0,75	2740	75,6	75,7	77,8	0,73	0,84	0,88	1,22	2790	74,4	76,0	77,8	0,65	0,78	0,84	1,17
0,75	1	2805	80,0	80,5	80,7	0,68	0,80	0,85	1,66	2835	79,1	81,0	81,1	0,59	0,72	0,79	1,63
1,1	1,5	2810	82,0	83,7	83,1	0,69	0,80	0,85	2,37	2840	80,0	83,0	83,4	0,58	0,72	0,79	2,32
1,5	2	2860	83,7	85,0	84,4	0,69	0,80	0,85	3,18	2885	82,2	84,8	85,2	0,59	0,72	0,80	3,06
2,2	3	2855	86,5	86,4	85,9	0,70	0,81	0,86	4,52	2880	85,3	86,4	86,5	0,61	0,74	0,81	4,37
3	4	2900	86,0	87,4	87,1	0,75	0,84	0,88	5,95	2915	85,0	87,2	87,4	0,66	0,78	0,84	5,68
4	5,5	2890	88,0	88,2	88,2	0,73	0,83	0,88	7,83	2905	87,5	88,0	88,4	0,65	0,77	0,84	7,49
5,5	7,5	2925	87,6	88,9	89,2	0,71	0,82	0,87	10,8	2935	86,1	88,3	89,2	0,61	0,74	0,81	10,6
7,5	10	2926	89,2	90,1	90,1	0,73	0,83	0,88	14,4	2940	87,9	89,7	90,3	0,63	0,76	0,83	13,9
9,2	12,5	2920	90,7	91,0	90,8	0,79	0,87	0,90	17,1	2935	90,1	91,0	91,3	0,71	0,82	0,87	16,1
11	15	2940	90,7	91,2	91,2	0,75	0,84	0,88	20,8	2950	89,9	91,3	91,4	0,68	0,79	0,85	19,7
15	20	2940	91,0	91,6	91,9	0,72	0,82	0,87	28,5	2950	90,3	91,6	91,9	0,63	0,76	0,82	27,7
18,5	25	2945	92,0	92,3	92,4	0,74	0,83	0,88	34,6	2950	91,0	92,2	92,4	0,64	0,77	0,83	33,6
22	30	2945	92,4	92,7	92,7	0,74	0,83	0,87	41,4	2955	92,0	92,8	92,7	0,66	0,78	0,84	39,3
30	40	2960	92,6	93,2	93,3	0,75	0,83	0,87	56,2	2965	91,8	93,0	93,3	0,64	0,76	0,82	54,6
37	50	2960	93,0	93,6	93,7	0,75	0,84	0,87	69,0	2965	92,0	93,2	93,7	0,63	0,76	0,82	67,0
45	60	2960	93,8	94,0	94,0	0,81	0,88	0,90	80,8	2965	94,0	94,0	94,3	0,75	0,84	0,88	75,4
55	75	2960	93,8	94,3	94,3	0,80	0,87	0,90	98,5	2965	93,4	94,3	94,4	0,73	0,83	0,87	93,2
75	100	2975	93,9	94,7	94,7	0,81	0,87	0,89	135	2980	93,5	94,7	94,9	0,76	0,84	0,87	126
90	125	2975	94,5	95,0	95,0	0,83	0,88	0,89	162	2980	94,2	95,2	95,2	0,78	0,86	0,88	149
110	150	2975	94,6	95,4	95,4	0,81	0,87	0,89	197	2980	94,1	95,2	95,4	0,75	0,84	0,87	184
132	175	2975	94,7	95,5	95,6	0,81	0,87	0,90	233	2980	94,3	95,4	95,6	0,75	0,84	0,88	218
150	200	2975	95,0	95,6	95,6	0,83	0,88	0,90	265	2980	94,7	95,6	95,6	0,78	0,85	0,89	245
160	220	2980	95,3	95,8	95,8	0,82	0,88	0,90	282	2980	94,9	95,8	95,8	0,77	0,85	0,88	264
185	250	2975	95,5	95,8	95,8	0,82	0,88	0,90	326	2980	95,2	95,8	95,8	0,77	0,85	0,88	305
200	270	2975	95,8	96,2	96,0	0,84	0,89	0,91	348	2980	95,6	96,2	96,0	0,80	0,87	0,89	326
220	300	2980	96,0	96,0	96,0	0,83	0,89	0,91	383	2980	95,8	96,0	96,0	0,79	0,86	0,89	358
250	340	2975	96,4	96,0	96,0	0,87	0,91	0,92	430	2980	96,3	96,0	96,0	0,83	0,89	0,91	398
260	350	2975	96,4	96,0	96,0	0,87	0,91	0,92	447	2980	96,3	96,0	96,0	0,83	0,89	0,91	414
280	380	2975	96,2	95,8	96,0	0,87	0,91	0,91	487	2980	96,2	95,8	96,0	0,85	0,89	0,90	451
315	430	2980	95,0	96,0	96,0	0,89	0,92	0,92	542	2985	95,2	95,6	95,8	0,86	0,90	0,92	497
330	450	2980	95,2	96,0	96,0	0,90	0,91	0,91	574	2985	95,6	96,2	96,2	0,88	0,91	0,92	519
355	480	2980	95,3	95,5	95,8	0,89	0,91	0,91	619	2985	95,3	95,6	95,8	0,85	0,89	0,91	567
370	500	2980	95,8	96,0	96,2	0,86	0,90	0,91	642	2985	95,5	96,3	96,5	0,84	0,88	0,89	599
400	550	2985	95,9	96,2	96,3	0,87	0,90	0,91	694	2985	95,7	96,2	96,5	0,84	0,88	0,91	634
450	610	2985	95,9	96,2	96,4	0,87	0,91	0,91	779	2985	95,7	96,2	96,4	0,84	0,89	0,91	714
Optional frames & high output designs																	
11	15	2915	90,9	91,0	91,2	0,80	0,87	0,90	20,4	2930	90,2	91,1	91,4	0,72	0,82	0,87	19,2
75	100	2960	94,0	94,5	94,7	0,85	0,88	0,90	134	2965	94,0	94,5	94,9	0,81	0,86	0,88	125
110	150	2975	95,0	95,2	95,2	0,84	0,89	0,91	193	2980	94,9	95,4	95,4	0,80	0,87	0,90	178
200	270	2975	95,8	96,2	96,0	0,84	0,89	0,91	348	2980	95,6	96,2	96,0	0,80	0,87	0,89	326

## W22 - Premium Efficiency - IE3 <sup>(1)</sup>

Output kW   HP		Frame	Full load torque (Nm)	Locked rotor current I/In	Locked rotor torque Tl/Tn	Breakdown torque Tl/Tn	Inertia J (kgm <sup>2</sup> )	Allowable locked rotor time (s)		Weight (kg)	Sound dB (A)	400 V						Full load current In (A)				
								Hot	Cold			% of full load			Full load current In (A)							
												Efficiency			Power factor							
												Rated speed (rpm)										
														50			75			100		
IV pole - 1500 rpm - 50 Hz																						
0,12	0,16	63	0,840	4,4	2,1	2,3	0,0004	30	66	5,2	44,0	1370	57,0	63,0	64,8	0,52	0,62	0,73	0,366			
0,18	0,25	63	1,26	4,7	2,1	2,4	0,0006	30	66	7,2	44,0	1370	65,0	67,0	69,9	0,53	0,63	0,72	0,516			
0,25	0,33	71	1,72	4,8	2,3	2,3	0,0009	30	66	8,0	43,0	1390	69,0	72,0	73,5	0,52	0,65	0,72	0,682			
0,37	0,5	71	2,55	4,8	2,8	2,9	0,0008	30	66	9,5	43,0	1385	73,0	75,0	77,3	0,50	0,62	0,70	0,987			
0,55	0,75	80	3,70	6,6	2,8	3,0	0,0027	20	44	12,5	44,0	1420	77,0	79,0	80,8	0,61	0,74	0,80	1,23			
0,75	1	80	5,05	6,7	3,0	3,3	0,0032	18	40	14,5	44,0	1420	80,0	82,0	82,5	0,59	0,72	0,81	1,62			
1,1	1,5	90S	7,25	7,6	2,5	3,3	0,0055	15	33	19,5	49,0	1450	83,0	84,5	84,5	0,59	0,72	0,80	2,35			
1,5	2	90L	9,88	7,4	2,6	3,4	0,0066	13	29	23,0	49,0	1450	84,0	86,0	85,5	0,58	0,72	0,80	3,17			
2,2	3	100L	14,7	7,4	3,2	3,5	0,0090	18	40	31,5	53,0	1435	86,5	87,0	87,0	0,60	0,73	0,80	4,56			
3	4	L100L	19,9	7,8	3,5	3,7	0,0120	15	33	37,5	53,0	1440	87,0	88,0	88,0	0,60	0,73	0,80	6,15			
4	5,5	112M	26,4	7,0	2,3	3,1	0,0180	15	33	44,0	56,0	1450	88,7	89,1	88,8	0,60	0,72	0,79	8,23			
5,5	7,5	132S	36,0	8,3	2,1	3,3	0,0491	12	26	66,0	56,0	1460	89,0	89,6	89,7	0,69	0,80	0,85	10,4			
7,5	10	132M	49,1	8,3	2,4	3,5	0,0563	7	15	74,0	56,0	1460	90,5	90,8	90,6	0,63	0,76	0,84	14,2			
9,2	12,5	132M/L	60,0	8,6	2,8	3,5	0,0698	10	22	82,0	56,0	1465	90,3	91,0	91,0	0,64	0,76	0,82	17,4			
11	15	160M	71,5	7,5	2,8	3,2	0,1191	11	24	113	61,0	1470	91,1	91,8	91,6	0,65	0,77	0,83	20,9			
15	20	160L	97,8	7,2	2,8	3,1	0,1534	8	18	135	61,0	1465	92,2	92,5	92,3	0,67	0,78	0,84	27,9			
18,5	25	180M	120	7,4	3,0	3,2	0,1740	13	29	168	61,0	1470	92,2	92,8	92,8	0,64	0,76	0,82	35,1			
22	30	180L	143	7,3	3,4	3,4	0,2097	11	24	185	61,0	1470	92,3	93,0	93,2	0,66	0,77	0,83	41,0			
30	40	200L	194	7,5	2,8	3,1	0,3202	12	26	228	63,0	1480	92,9	93,6	93,7	0,63	0,75	0,81	57,1			
37	50	225S/M	239	7,7	2,8	3,3	0,5177	13	29	365	63,0	1480	93,4	94,0	94,1	0,70	0,80	0,85	66,8			
45	60	225S/M	292	7,5	2,8	3,1	0,6733	14	31	400	63,0	1475	93,7	94,1	94,4	0,71	0,81	0,85	80,9			
55	75	250S/M	355	7,5	2,8	3,0	1,05	14	31	440	64,0	1480	94,3	94,7	94,7	0,69	0,80	0,85	98,6			
75	100	280S/M	483	7,5	2,2	2,9	2,09	30	66	630	69,0	1485	94,5	95,1	95,2	0,72	0,82	0,85	134			
90	125	280S/M	579	7,0	2,2	2,5	2,17	30	66	700	69,0	1485	94,9	95,4	95,4	0,75	0,83	0,86	158			
110	150	315S/M	705	7,4	2,2	2,6	2,89	33	73	950	71,0	1490	94,7	95,5	95,6	0,74	0,82	0,86	193			
132	175	315S/M	846	7,5	2,5	2,7	3,79	30	66	1010	71,0	1490	95,1	95,7	95,8	0,74	0,82	0,86	231			
150	200	315S/M	962	7,8	2,7	2,7	3,77	27	59	1030	71,0	1490	95,4	95,8	95,9	0,71	0,81	0,85	266			
160	220	315S/M	1026	7,7	2,6	2,7	3,99	28	62	1080	71,0	1490	95,2	95,9	96,0	0,74	0,82	0,86	280			
185	250	315S/M	1186	7,8	2,7	2,9	4,42	25	55	1150	71,0	1490	95,5	96,1	96,0	0,71	0,80	0,85	327			
200	270	315L	1287	6,7	2,4	2,4	4,75	21	46	1200	73,0	1485	96,0	96,3	96,0	0,78	0,85	0,87	346			
220	300	315L	1411	7,9	2,8	2,8	5,30	12	26	1340	73,0	1490	95,8	96,1	96,2	0,72	0,81	0,85	388			
250	340	315L	1603	7,9	2,9	2,7	5,75	19	42	1430	73,0	1490	96,0	96,2	96,2	0,73	0,82	0,86	436			
260	350	315L	1667	7,9	2,9	2,7	6,41	19	42	1430	73,0	1490	96,0	96,2	96,2	0,73	0,82	0,86	454			
280	380	355M/L	1796	7,3	2,4	2,6	9,66	20	44	1600	74,0	1490	95,9	96,0	96,2	0,74	0,83	0,86	488			
300	400	315L	1924	7,6	2,7	3,0	6,54	12	26	1600	73,0	1490	95,8	96,0	96,2	0,74	0,82	0,86	523			
315	430	355M/L	2020	7,9	2,5	2,6	9,47	17	37	1750	74,0	1490	96,1	96,3	96,3	0,72	0,81	0,85	555			
330	450	355M/L	2116	7,1	2,5	2,5	10,7	20	44	1810	74,0	1490	95,8	96,0	96,2	0,71	0,82	0,85	583			
355	480	355M/L	2277	7,2	2,4	2,5	11,6	15	33	1878	74,0	1490	95,9	96,5	96,5	0,74	0,83	0,86	617			
400	550	355A/B <sup>(4)</sup>	2565	7,6	2,6	2,9	13,2	20	44	2089	76,0	1490	95,7	96,1	96,2	0,68	0,79	0,84	714			
450	610	355A/B <sup>(4)</sup>	2886	7,4	2,5	2,8	13,2	20	44	2089	76,0	1490	95,8	96,1	96,2	0,69	0,80	0,84	804			
500	680	355A/B <sup>(3/4)</sup>	3206	7,3	2,4	2,7	14,6	17	37	2246	76,0	1490	95,9	96,3	96,3	0,72	0,81	0,85	882			
Optional frames & high output designs																						
37	50	200L	239	7,0	2,6	3,0	0,3994	14	31	284	63,0	1480	93,1	93,6	94,1	0,64	0,76	0,82	69,2			
75	100	250S/M	484	7,8	2,8	3,3	1,22	8	18	530	64,0	1480	95,0	95,5	95,2	0,73	0,83	0,87	131			
110	150	280S/M	708	7,7	2,5	2,9	3,25	19	42	800	69,0	1485	95,3	95,6	95,6	0,73	0,82	0,86	193			
200	270	315S/M	1287	6,7	2,4	2,4	5,30	21	46	1332	71,0	1485	95,8	96,0	96,0	0,78	0,85	0,87	346			

(1) Efficiency values are given according to IEC 60034-2-1. They are calculated according to indirect method, with stray load losses determined by measurement.

(3) Motor with class F (105K) temperature rise.

(4) Fitted with air deflector in the drive end side.

**W22 - Premium Efficiency - IE3 <sup>(1)</sup>**

Output		380 V								415 V							
		Rated speed (rpm)	% of full load						Full load current In (A)	Rated speed (rpm)	% of full load						Full load current In (A)
			Efficiency			Power factor					Efficiency			Power factor			
KW	HP	50	75	100	50	75	100	50	75	100	50	75	100	50	75	100	
IV pole - 1500 rpm - 50 Hz																	
0,12	0,16	1355	58,6	64,0	64,8	0,56	0,69	0,76	0,370	1380	55,6	63,0	64,8	0,50	0,62	0,72	0,358
0,18	0,25	1355	65,0	67,0	69,9	0,57	0,67	0,75	0,522	1380	65,0	67,0	69,9	0,50	0,61	0,70	0,512
0,25	0,33	1375	67,0	69,1	73,5	0,56	0,69	0,75	0,689	1400	65,1	68,6	73,4	0,50	0,62	0,69	0,687
0,37	0,5	1370	73,0	75,0	77,3	0,53	0,64	0,72	1,01	1395	73,0	75,0	77,3	0,47	0,59	0,68	0,979
0,55	0,75	1410	78,0	79,1	80,8	0,65	0,77	0,83	1,25	1430	76,0	78,9	80,8	0,57	0,71	0,77	1,23
0,75	1	1410	80,8	82,0	82,5	0,64	0,75	0,83	1,66	1425	79,1	81,8	82,8	0,56	0,69	0,79	1,60
1,1	1,5	1445	84,0	84,7	84,3	0,64	0,76	0,83	2,39	1455	82,0	84,1	84,8	0,55	0,69	0,77	2,34
1,5	2	1445	85,0	86,2	85,6	0,63	0,76	0,83	3,21	1455	83,1	85,7	86,1	0,54	0,68	0,77	3,15
2,2	3	1430	87,2	87,1	86,7	0,65	0,77	0,83	4,64	1440	85,7	86,8	87,2	0,57	0,70	0,78	4,50
3	4	1430	87,7	88,0	87,7	0,65	0,77	0,83	6,26	1445	86,3	87,7	88,1	0,56	0,70	0,78	6,07
4	5,5	1445	89,3	89,0	88,6	0,65	0,76	0,81	8,47	1455	88,2	88,9	89,3	0,57	0,70	0,77	8,09
5,5	7,5	1460	89,0	89,6	89,6	0,73	0,83	0,87	10,7	1465	89,4	89,6	89,8	0,65	0,78	0,84	10,1
7,5	10	1460	90,0	90,2	90,4	0,66	0,79	0,86	14,7	1465	89,2	90,3	90,4	0,60	0,73	0,83	13,9
9,2	12,5	1460	91,0	91,1	91,0	0,69	0,80	0,85	17,7	1470	89,5	90,6	91,0	0,60	0,73	0,80	17,2
11	15	1470	91,7	91,4	91,4	0,69	0,80	0,85	21,5	1475	90,6	91,4	91,5	0,61	0,74	0,81	20,6
15	20	1465	92,4	92,4	92,1	0,70	0,80	0,85	29,1	1470	91,6	92,3	92,1	0,62	0,75	0,81	28,0
18,5	25	1470	92,7	92,6	92,6	0,69	0,79	0,84	36,1	1475	91,8	92,6	92,6	0,61	0,73	0,80	34,7
22	30	1470	92,5	92,8	93,0	0,70	0,81	0,85	42,3	1475	91,9	92,8	93,0	0,62	0,74	0,81	40,6
30	40	1475	93,4	93,6	93,6	0,68	0,79	0,84	58,0	1480	92,3	93,3	93,6	0,59	0,72	0,79	56,4
37	50	1480	93,7	93,9	93,9	0,74	0,83	0,86	69,6	1480	93,1	93,9	93,9	0,66	0,78	0,83	66,0
45	60	1475	93,8	94,0	94,2	0,75	0,83	0,87	83,4	1480	93,5	94,1	94,4	0,68	0,79	0,84	79,0
55	75	1480	94,5	94,6	94,7	0,73	0,82	0,86	103	1480	94,0	94,6	94,6	0,66	0,78	0,83	97,5
75	100	1485	94,7	94,9	95,0	0,75	0,83	0,86	139	1490	94,4	94,9	95,2	0,70	0,79	0,84	130
90	125	1480	95,2	95,4	95,2	0,77	0,84	0,87	165	1485	95,0	95,4	95,4	0,72	0,81	0,85	154
110	150	1489	95,0	95,5	95,5	0,78	0,85	0,87	201	1490	94,4	95,4	95,5	0,71	0,81	0,85	189
132	175	1490	95,3	95,6	95,6	0,77	0,84	0,87	241	1490	94,8	95,6	95,6	0,71	0,81	0,85	226
150	200	1490	95,4	95,8	95,9	0,76	0,84	0,87	273	1490	95,4	95,9	96,0	0,69	0,79	0,84	259
160	220	1490	95,7	95,8	95,8	0,77	0,84	0,87	292	1490	95,3	95,8	95,8	0,71	0,81	0,85	273
185	250	1490	95,8	96,0	96,0	0,75	0,83	0,86	340	1490	95,2	96,0	96,0	0,68	0,78	0,83	323
200	270	1485	96,1	96,2	96,0	0,80	0,86	0,88	360	1490	95,9	96,3	96,1	0,76	0,83	0,87	333
220	300	1490	96,0	96,4	96,3	0,75	0,83	0,87	399	1490	95,5	96,2	96,2	0,69	0,79	0,84	379
250	340	1490	95,8	96,0	96,2	0,77	0,84	0,87	454	1490	96,0	96,2	96,4	0,71	0,80	0,85	424
260	350	1490	95,8	96,0	96,2	0,77	0,84	0,87	472	1490	96,0	96,2	96,4	0,71	0,80	0,85	441
280	380	1490	95,8	96,0	96,2	0,77	0,84	0,87	508	1490	96,0	96,2	96,3	0,71	0,81	0,85	476
300	400	1489	95,8	96,1	96,0	0,77	0,84	0,87	546	1490	95,2	95,9	96,0	0,70	0,80	0,85	511
315	430	1490	95,8	96,0	96,0	0,75	0,83	0,86	580	1490	95,9	96,0	96,0	0,68	0,79	0,84	543
330	450	1490	95,8	96,2	96,2	0,80	0,86	0,88	592	1490	95,8	96,2	96,2	0,75	0,83	0,87	549
355	480	1490	96,0	96,4	96,5	0,77	0,85	0,87	642	1490	95,8	96,5	96,6	0,72	0,82	0,85	601
400	550	1490	96,0	96,2	96,1	0,72	0,82	0,86	735	1490	95,4	95,9	96,1	0,65	0,76	0,82	706
450	610	1490	96,0	96,2	96,2	0,73	0,83	0,86	826	1490	95,5	95,9	96,1	0,65	0,77	0,82	794
500	680	1490	96,1	96,3	96,3	0,76	0,84	0,87	907	1490	95,7	96,2	96,3	0,69	0,79	0,84	860
Optional frames & high output designs																	
37	50	1480	92,9	93,4	93,9	0,69	0,79	0,84	71,3	1480	93,0	93,5	94,0	0,60	0,73	0,80	68,5
75	100	1475	95,0	95,2	95,2	0,77	0,86	0,88	136	1480	94,7	95,0	95,2	0,70	0,81	0,86	127
110	150	1480	95,4	95,4	95,4	0,77	0,84	0,87	201	1485	95,2	95,6	95,6	0,71	0,81	0,85	188
200	270	1485	95,8	96,0	96,0	0,80	0,86	0,88	360	1490	95,9	96,0	96,1	0,76	0,83	0,87	333

## W22 - Premium Efficiency - IE3 <sup>(1)</sup>

Output		Frame	Full load torque (Nm)	Locked rotor current I <sub>L</sub> /I <sub>n</sub>	Locked rotor torque T <sub>L</sub> /T <sub>n</sub>	Breakdown torque T <sub>b</sub> /T <sub>n</sub>	Inertia J (kgm <sup>2</sup> )	Allowable locked rotor time (s)		Weight (kg)	Sound dB (A)	Rated speed (rpm)	400 V						Full load current I <sub>n</sub> (A)
								Hot	Cold				% of full load			Power factor			
													50	75	100	50	75	100	
VI pole - 1000 rpm - 50 Hz																			
0,12	0,16	63	1,24	3,1	2,1	2,3	0,0007	30	66	7,7	43,0	925	50,0	55,0	57,7	0,40	0,50	0,59	0,509
0,18	0,25	71	1,91	3,2	2,0	2,1	0,0009	30	66	11,5	43,0	900	56,0	62,0	63,9	0,38	0,48	0,57	0,713
0,25	0,33	80	2,50	4,3	1,7	2,4	0,0029	25	55	12,0	43,0	955	63,6	68,5	68,8	0,47	0,60	0,71	0,739
0,37	0,5	80	3,82	4,5	1,9	2,1	0,0025	25	55	12,5	43,0	925	66,0	69,5	73,5	0,51	0,65	0,75	0,969
0,55	0,75	L80	5,56	5,1	2,9	3,1	0,0037	20	44	15,5	43,0	945	70,5	75,2	77,2	0,45	0,58	0,69	1,49
0,75	1	L90S	7,62	5,2	2,5	2,8	0,0060	31	68	22,0	45,0	940	76,5	79,0	79,0	0,49	0,62	0,71	1,93
1,1	1,5	L90L	11,1	5,5	2,5	2,8	0,0077	20	44	26,0	45,0	945	79,3	81,4	81,0	0,50	0,64	0,73	2,69
1,5	2	100L	15,1	5,5	2,3	2,8	0,0143	31	68	32,0	44,0	950	81,5	82,5	82,5	0,49	0,62	0,71	3,70
2,2	3	112M	22,1	6,0	2,5	2,6	0,0257	26	57	46,0	52,0	950	83,0	84,5	84,5	0,53	0,64	0,72	5,22
3	4	132S	29,7	5,8	1,8	2,6	0,0416	40	88	65,0	53,0	965	85,0	85,6	85,8	0,53	0,66	0,73	6,91
4	5,5	132M	39,6	6,1	1,9	2,7	0,0492	25	55	70,0	53,0	965	86,0	86,8	86,8	0,53	0,66	0,73	9,11
5,5	7,5	132M/L	54,5	7,0	2,5	2,8	0,0755	26	57	78,0	53,0	965	86,5	88,0	88,0	0,50	0,64	0,70	12,9
7,5	10	160M	73,5	6,3	2,2	2,7	0,1404	16	35	118	56,0	975	88,5	89,3	89,3	0,64	0,76	0,82	14,8
9,2	12,5	160L	90,2	6,5	2,3	2,9	0,1756	18	40	135	56,0	975	90,0	90,6	90,0	0,64	0,75	0,81	18,2
11	15	160L	108	7,1	2,8	3,2	0,1931	12	26	140	56,0	975	89,0	90,1	90,5	0,60	0,73	0,80	21,9
15	20	180L	147	7,7	2,6	3,2	0,2970	8	18	185	56,0	975	91,5	91,5	91,4	0,68	0,79	0,84	28,2
18,5	25	200L	180	6,3	2,4	2,8	0,3510	16	35	215	60,0	980	91,0	91,7	91,9	0,63	0,75	0,81	35,9
22	30	200L	215	6,4	2,4	2,8	0,4212	15	33	225	60,0	980	91,4	92,0	92,4	0,64	0,76	0,81	42,4
30	40	225S/M	291	7,5	2,4	2,8	0,8194	15	33	380	63,0	985	93,0	93,4	93,1	0,67	0,78	0,83	56,0
37	50	250S/M	359	7,2	2,4	2,7	1,24	20	44	430	64,0	985	93,3	93,5	93,5	0,72	0,81	0,85	67,2
45	60	280S/M	437	6,4	2,1	2,7	2,35	28	62	640	65,0	985	93,9	93,9	93,9	0,67	0,77	0,82	84,4
55	75	280S/M	534	6,8	2,3	2,8	2,69	24	53	665	65,0	985	94,0	94,2	94,3	0,66	0,77	0,82	103
75	100	315S/M	724	6,3	2,0	2,5	4,35	37	81	920	67,0	990	94,6	94,9	94,9	0,67	0,77	0,82	139
90	125	315S/M	869	6,4	2,2	2,5	5,42	35	77	990	67,0	990	95,1	95,5	95,1	0,68	0,78	0,83	165
110	150	315S/M	1062	6,2	2,1	2,4	6,15	31	68	1040	67,0	990	95,4	95,6	95,3	0,70	0,80	0,83	201
132	175	315S/M	1274	7,2	2,6	2,7	7,23	25	55	1100	67,0	990	95,4	95,8	95,6	0,67	0,77	0,82	243
150	200	315L	1448	6,5	2,3	2,5	7,96	25	55	1200	68,0	990	95,4	95,8	95,7	0,67	0,78	0,83	273
160	220	315L	1544	7,5	2,7	2,8	6,87	22	48	1230	68,0	990	95,6	95,6	95,8	0,67	0,77	0,82	294
185	250	315L	1786	7,1	2,4	2,6	9,22	20	44	1300	68,0	990	95,0	95,8	95,8	0,65	0,76	0,81	344
200	270	355M/L	1930	6,1	2,2	2,3	10,4	39	86	1620	73,0	990	95,5	96,0	95,9	0,66	0,76	0,80	376
220	300	355M/L	2113	6,5	2,0	2,2	12,0	36	79	1710	73,0	995	95,5	96,1	96,0	0,63	0,74	0,79	419
250	340	355M/L	2413	6,4	2,2	2,3	13,9	38	84	1830	73,0	990	95,7	95,9	95,9	0,64	0,75	0,79	476
260	350	355M/L	2509	6,4	2,2	2,3	13,9	38	84	1830	73,0	990	95,7	95,9	95,9	0,64	0,75	0,79	495
280	380	355M/L	2689	5,5	1,9	2,2	15,0	38	84	1970	73,0	995	95,1	95,1	96,0	0,64	0,75	0,80	526
300	400	355M/L	2895	5,8	1,9	2,0	15,0	25	55	2493	73,0	990	95,8	96,0	96,0	0,63	0,74	0,80	564
315	430	355M/L <sup>(4)</sup>	3040	6,1	2,1	2,1	15,0	25	55	2493	73,0	990	95,2	95,8	95,8	0,66	0,76	0,80	593
355	480	355A/B <sup>(4)</sup>	3426	6,2	2,0	2,3	17,1	29	64	2200	73,0	990	95,3	95,7	95,8	0,63	0,74	0,79	677
370	500	355A/B <sup>(4)</sup>	3571	6,0	2,2	2,3	18,0	25	55	2300	73,0	990	95,4	95,8	95,9	0,63	0,74	0,79	705
400	550	355A/B <sup>(4)</sup>	3861	6,1	2,0	2,3	18,9	29	64	2346	73,0	990	95,4	95,8	95,9	0,63	0,74	0,79	762
Optional frames & high output designs																			
45	60	250S/M	437	7,7	2,8	2,8	1,43	18	40	490	64,0	985	92,4	93,9	93,9	0,76	0,84	0,87	79,5
75	100	280S/M	724	7,9	2,7	3,2	4,48	17	37	725	65,0	990	94,1	94,7	94,7	0,63	0,75	0,81	141
150	200	315S/M	1448	6,5	2,3	2,5	7,96	20	44	1180	67,0	990	95,4	95,8	95,7	0,67	0,78	0,83	273

Notes:

- (1) Efficiency values are given according to IEC 60034-2-1. They are calculated according to indirect method, with stray load losses determined by measurement.
- (3) Motor with class F (105K) temperature rise.
- (4) Fitted with air deflector in the drive end side.



**W22 - Premium Efficiency - IE3 <sup>(1)</sup>**

Output		380 V								415 V							
		Rated speed (rpm)	% of full load						Full load current In (A)	Rated speed (rpm)	% of full load						Full load current In (A)
			Efficiency			Power factor					Efficiency			Power factor			
kW	HP	50	75	100	50	75	100	50	75	100	50	75	100	50	75	100	
VI pole - 1000 rpm - 50 Hz																	
0,12	0,16	910	48,7	54,7	57,7	0,40	0,53	0,63	0,502	930	50,0	55,0	57,7	0,39	0,47	0,56	0,517
0,18	0,25	885	57,7	62,8	63,9	0,43	0,55	0,64	0,669	910	54,5	61,2	63,9	0,38	0,48	0,57	0,688
0,25	0,33	950	65,9	68,0	68,6	0,51	0,64	0,74	0,748	960	61,7	68,2	68,8	0,45	0,57	0,68	0,743
0,37	0,5	915	67,6	69,9	73,5	0,55	0,69	0,79	0,968	930	64,3	68,8	73,5	0,48	0,62	0,72	0,973
0,55	0,75	940	73,4	76,7	77,2	0,49	0,63	0,73	1,48	950	67,9	75,0	77,2	0,42	0,55	0,65	1,52
0,75	1	930	77,5	79,2	78,9	0,53	0,66	0,74	1,95	945	75,3	78,6	79,1	0,46	0,59	0,69	1,91
1,1	1,5	940	81,0	82,0	81,0	0,55	0,69	0,77	2,68	950	77,7	80,7	81,0	0,47	0,61	0,70	2,70
1,5	2	945	82,3	82,6	82,5	0,53	0,66	0,74	3,73	955	80,6	82,3	82,8	0,46	0,59	0,68	3,71
2,2	3	945	83,6	84,4	84,3	0,57	0,68	0,75	5,29	955	82,3	84,3	84,7	0,50	0,62	0,70	5,16
3	4	960	85,0	85,8	85,8	0,57	0,69	0,76	6,99	970	85,2	85,8	86,0	0,49	0,63	0,71	6,84
4	5,5	960	86,3	86,8	86,8	0,57	0,70	0,76	9,21	970	85,4	86,5	86,8	0,49	0,62	0,71	9,03
5,5	7,5	960	87,4	88,3	88,0	0,55	0,68	0,75	12,7	965	85,8	87,7	88,0	0,47	0,61	0,69	12,6
7,5	10	970	88,9	89,0	89,1	0,68	0,79	0,84	15,2	980	88,0	89,0	89,1	0,61	0,73	0,80	14,6
9,2	12,5	970	89,5	90,0	90,0	0,68	0,78	0,83	18,7	975	89,6	90,0	90,0	0,61	0,73	0,79	18,0
11	15	975	89,7	90,3	90,3	0,65	0,77	0,83	22,3	980	88,3	89,8	90,3	0,57	0,70	0,78	21,7
15	20	975	90,7	91,0	91,2	0,72	0,81	0,86	29,1	980	91,3	91,6	91,2	0,65	0,77	0,84	27,3
18,5	25	980	91,0	91,7	91,7	0,68	0,78	0,83	36,9	985	90,3	91,4	91,7	0,59	0,72	0,78	36,0
22	30	980	92,0	92,2	92,2	0,69	0,79	0,84	43,2	980	90,8	91,8	92,2	0,60	0,72	0,79	42,0
30	40	985	93,3	93,3	92,9	0,71	0,80	0,85	57,7	985	92,8	93,4	93,0	0,64	0,75	0,82	54,7
37	50	980	93,3	93,3	93,3	0,75	0,83	0,87	69,3	985	93,3	93,5	93,5	0,69	0,80	0,84	65,5
45	60	985	93,7	93,8	93,8	0,70	0,80	0,83	87,8	990	93,7	94,0	94,0	0,64	0,75	0,81	82,2
55	75	985	94,0	94,2	94,2	0,70	0,79	0,83	107	990	94,0	94,3	94,3	0,63	0,75	0,81	100
75	100	990	94,6	94,8	94,8	0,71	0,80	0,83	145	990	94,3	95,0	95,0	0,64	0,75	0,80	137
90	125	990	95,0	95,1	95,1	0,72	0,80	0,84	171	990	95,0	95,1	95,2	0,65	0,76	0,81	162
110	150	990	94,8	95,0	95,1	0,74	0,82	0,84	209	990	94,8	95,1	95,1	0,68	0,78	0,82	196
132	175	990	95,4	95,8	95,6	0,69	0,79	0,84	250	990	95,4	95,8	95,6	0,65	0,75	0,80	240
150	200	990	95,4	95,7	95,7	0,69	0,80	0,85	280	990	95,4	95,5	95,7	0,65	0,76	0,81	269
160	220	990	95,5	95,8	95,8	0,71	0,80	0,84	302	990	95,3	95,8	95,8	0,64	0,75	0,81	287
185	250	990	94,8	95,3	95,8	0,70	0,79	0,83	353	990	94,8	95,3	95,8	0,62	0,74	0,80	336
200	270	990	95,7	96,0	95,8	0,70	0,79	0,82	387	990	95,3	95,9	95,9	0,63	0,74	0,79	367
220	300	995	95,5	95,9	96,0	0,65	0,76	0,81	430	995	95,5	96,1	96,1	0,61	0,72	0,77	414
250	340	990	95,8	95,8	95,8	0,68	0,77	0,80	496	995	95,5	96,0	96,0	0,61	0,73	0,78	464
260	350	990	95,0	95,8	95,8	0,68	0,77	0,80	515	995	95,5	96,0	96,0	0,61	0,73	0,78	483
280	380	990	95,7	96,1	96,0	0,68	0,77	0,81	547	995	95,2	96,0	96,1	0,61	0,72	0,78	520
300	400	990	95,8	96,0	96,0	0,65	0,76	0,82	579	990	95,8	96,0	96,0	0,61	0,73	0,78	557
315	430	991	95,8	96,2	96,0	0,68	0,78	0,81	615	993	95,3	96,0	96,1	0,61	0,73	0,78	585
355	480	990	95,4	95,7	95,8	0,64	0,75	0,79	713	990	95,2	95,7	95,9	0,62	0,73	0,79	652
370	500	990	95,6	95,8	95,8	0,65	0,76	0,81	724	995	95,2	95,7	95,9	0,61	0,72	0,77	697
400	550	990	95,7	95,9	95,9	0,67	0,77	0,81	782	990	95,2	95,7	95,9	0,60	0,71	0,77	754
Optional frames & high output designs																	
45	60	985	92,9	93,9	93,8	0,80	0,86	0,88	82,8	985	91,9	93,9	93,9	0,73	0,82	0,86	77,5
75	100	990	94,4	94,6	94,6	0,67	0,78	0,83	145	990	93,8	94,6	94,7	0,60	0,72	0,79	139
150	200	990	94,6	95,1	95,6	0,72	0,81	0,84	284	990	94,6	95,1	95,6	0,65	0,76	0,81	269

## W22 - Premium Efficiency - IE3 <sup>(1)</sup>

Output		Frame	Full load torque (Nm)	Locked rotor current I <sub>L</sub> /I <sub>n</sub>	Locked rotor torque T <sub>L</sub> /T <sub>n</sub>	Breakdown torque T <sub>b</sub> /T <sub>n</sub>	Inertia J (kgm <sup>2</sup> )	Allowable locked rotor time (s)		Weight (kg)	Sound dB (A)	Rated speed (rpm)	400 V						Full load current I <sub>n</sub> (A)
								Hot	Cold				% of full load			Power factor			
													50	75	100	50	75	100	
VIII poles - 750 rpm - 50 Hz																			
0,12	0,16	71	1,76	2,4	1,8	2,0	0,0009	30	66	11,5	41,0	650	44,0	50,0	52,5	0,35	0,43	0,50	0,660
0,18	0,25	80	2,53	3,3	2,0	2,2	0,0029	30	66	13,5	42,0	680	51,0	57,0	58,7	0,45	0,55	0,65	0,681
0,25	0,33	80	3,49	3,5	2,0	2,2	0,0034	30	66	14,5	42,0	685	53,0	60,0	64,1	0,42	0,52	0,63	0,894
0,37	0,5	90S	5,12	3,7	2,0	2,3	0,0055	30	66	19,0	43,0	690	61,0	66,0	69,3	0,41	0,53	0,62	1,24
0,55	0,75	90L	7,62	3,8	1,9	2,2	0,0066	29	64	23,0	43,0	690	65,0	70,0	73,0	0,44	0,57	0,67	1,62
0,75	1	100L	10,1	4,6	1,9	2,3	0,0127	30	66	30,5	50,0	710	72,5	75,5	75,5	0,41	0,53	0,62	2,31
1,1	1,5	100L	14,8	4,6	2,1	2,4	0,0143	30	66	33,0	50,0	710	73,0	76,0	77,7	0,41	0,53	0,62	3,30
1,5	2	112M	20,3	5,0	2,5	2,8	0,0238	28	62	43,0	46,0	705	79,0	79,5	79,9	0,45	0,59	0,68	3,98
2,2	3	132S	29,6	6,2	2,3	2,5	0,0690	27	59	69,0	48,0	710	81,5	82,0	82,1	0,51	0,65	0,72	5,37
3	4	132M	40,4	6,4	2,4	2,6	0,0838	21	46	75,0	48,0	710	82,5	83,5	83,5	0,51	0,64	0,72	7,20
4	5,5	160M	52,4	5,0	2,1	2,3	0,1229	34	75	114	51,0	730	85,0	86,0	86,0	0,47	0,61	0,68	9,87
5,5	7,5	160M	72,5	5,0	2,1	2,3	0,1492	28	62	123	51,0	725	86,0	87,3	87,3	0,52	0,65	0,73	12,5
7,5	10	160L	98,2	5,3	2,2	2,5	0,2199	22	48	145	51,0	730	87,0	88,3	88,5	0,52	0,65	0,73	16,8
9,2	12,5	180M	121	6,0	2,0	2,6	0,2575	15	33	173	51,0	725	89,0	89,3	89,6	0,63	0,75	0,82	18,1
11	15	180L	144	6,5	2,3	2,7	0,2846	12	26	185	51,0	730	88,7	89,2	89,7	0,55	0,68	0,76	23,3
15	20	200L	196	4,8	1,9	2,1	0,4571	34	75	220	56,0	730	89,0	89,6	89,8	0,56	0,68	0,74	32,6
18,5	25	225S/M	241	6,5	1,7	2,5	0,8219	28	62	377	56,0	735	89,8	90,3	90,3	0,63	0,75	0,81	36,5
22	30	225S/M	286	6,5	1,8	2,5	0,9574	22	48	402	56,0	735	90,3	90,8	90,8	0,63	0,75	0,81	43,2
30	40	250S/M	393	7,4	1,9	2,8	1,43	18	40	490	56,0	730	91,0	91,5	91,5	0,66	0,77	0,83	57,0
37	50	280S/M	478	6,0	1,8	2,3	2,82	32	70	673	59,0	740	91,5	92,0	92,0	0,63	0,73	0,79	73,5
45	60	280S/M	581	6,0	1,8	2,2	3,49	30	66	720	59,0	740	92,2	92,4	92,4	0,63	0,73	0,79	89,0
55	75	315S/M	710	6,0	1,7	2,2	5,11	40	88	960	62,0	740	92,2	92,7	92,7	0,65	0,75	0,80	107
75	100	315S/M	968	6,0	1,8	2,2	6,56	40	88	1025	62,0	740	92,8	93,3	93,3	0,65	0,75	0,80	145
90	125	315S/M	1162	6,0	1,9	2,2	7,84	40	88	1100	62,0	740	93,1	93,6	93,6	0,65	0,75	0,80	173
110	150	315L	1420	6,0	1,9	2,2	9,46	35	77	1367	68,0	740	93,4	93,9	93,9	0,64	0,74	0,79	214
132	175	355M/L	1693	6,2	1,3	2,3	14,1	48	106	1587	70,0	745	93,7	94,2	94,2	0,64	0,74	0,79	256
160	220	355M/L	2052	6,4	1,3	2,3	17,4	56	123	1747	70,0	745	94,0	94,5	94,5	0,64	0,75	0,80	305
185	250	355M/L	2373	6,3	1,3	2,3	18,5	56	123	1819	70,0	745	94,2	94,7	94,7	0,64	0,75	0,80	352
200	270	355M/L	2565	6,2	1,3	2,3	18,9	56	123	1891	70,0	745	94,3	94,8	94,8	0,65	0,76	0,80	381
220	300	355M/L	2822	7,2	1,8	2,5	19,8	30	66	2020	70,0	745	94,8	95,6	95,6	0,65	0,76	0,80	415
250	340	355A/B <sup>(4)</sup>	3206	6,2	1,5	2,4	21,7	47	103	2092	70,0	745	95,1	95,7	95,8	0,62	0,73	0,79	477
260	350	355A/B <sup>(4)</sup>	3335	6,2	1,5	2,4	21,7	47	103	2092	70,0	745	95,1	95,7	95,8	0,62	0,73	0,79	496
280	380	355A/B <sup>(4)</sup>	3591	7,5	2,0	2,8	25,0	44	97	2279	70,0	745	95,1	95,7	95,8	0,61	0,73	0,79	534
Optional frames & high output designs																			
37	50	250S/M	481	8,5	2,8	3,3	1,61	12	26	550	56,0	735	91,5	92,0	92,0	0,60	0,72	0,79	73,5
55	75	280S/M	710	5,8	2,0	2,1	3,38	26	57	812	59,0	740	92,2	92,7	92,7	0,60	0,71	0,77	111
110	150	315S/M	1420	6,0	1,9	2,2	9,46	35	77	1360	62,0	740	93,4	93,9	93,9	0,64	0,74	0,79	214
132	175	315L	1704	6,0	2,0	2,3	11,3	34	75	1508	68,0	740	93,7	94,2	94,2	0,64	0,74	0,79	256

Note:

(1) Efficiency values are given according to IEC 60034-2-1. They are calculated according to indirect method, with stray load losses determined by measurement.

(4) Fitted with air deflector in the drive end side.

**W22 - Premium Efficiency - IE3 <sup>(1)</sup>**

Output		380 V									415 V								
		Rated speed (rpm)	% of full load						Full load current In (A)	Rated speed (rpm)	% of full load						Full load current In (A)		
			Efficiency			Power factor					Efficiency			Power factor					
kW	HP	50	75	100	50	75	100	50	75	100	50	75	100	50	75	100			
VIII poles - 750 rpm - 50 Hz																			
0,12	0,16	635	46,6	51,7	52,9	0,38	0,46	0,54	0,638	655	41,8	48,2	51,4	0,34	0,41	0,48	0,677		
0,18	0,25	670	52,8	58,0	58,7	0,48	0,59	0,69	0,675	685	49,3	56,0	58,7	0,43	0,53	0,62	0,688		
0,25	0,33	695	54,0	60,0	64,1	0,44	0,57	0,67	0,884	705	56,0	62,0	64,3	0,39	0,50	0,60	0,902		
0,37	0,5	700	61,0	66,0	69,3	0,44	0,56	0,66	1,23	710	62,0	67,0	69,5	0,38	0,50	0,59	1,26		
0,55	0,75	695	65,0	70,0	73,0	0,49	0,62	0,70	1,64	705	65,0	70,0	73,0	0,42	0,55	0,64	1,64		
0,75	1	705	73,9	76,1	75,1	0,44	0,57	0,66	2,30	715	71,1	74,8	75,5	0,38	0,50	0,59	2,34		
1,1	1,5	700	74,9	76,8	77,7	0,45	0,58	0,66	3,26	710	71,1	76,0	77,7	0,38	0,50	0,59	3,34		
1,5	2	700	79,0	79,5	79,7	0,49	0,63	0,71	4,03	710	77,9	79,7	79,9	0,42	0,56	0,65	4,02		
2,2	3	705	81,5	81,9	81,9	0,57	0,68	0,76	5,37	715	81,0	82,0	82,2	0,48	0,62	0,70	5,32		
3	4	705	83,4	83,5	83,5	0,56	0,68	0,75	7,28	715	81,5	83,2	83,7	0,48	0,61	0,70	7,12		
4	5,5	725	85,6	86,8	86,1	0,51	0,64	0,70	10,1	735	84,4	86,6	86,8	0,44	0,58	0,66	9,71		
5,5	7,5	720	86,7	87,3	87,2	0,56	0,68	0,76	12,6	730	85,2	87,0	87,8	0,49	0,62	0,71	12,3		
7,5	10	725	87,8	88,5	88,6	0,56	0,69	0,76	16,9	730	86,2	88,0	88,9	0,49	0,62	0,71	16,5		
9,2	12,5	720	89,2	89,1	88,9	0,67	0,78	0,84	18,7	730	88,6	89,3	90,0	0,60	0,73	0,80	17,8		
11	15	725	88,5	89,0	89,5	0,59	0,71	0,77	24,3	730	89,0	89,5	90,0	0,52	0,65	0,74	23,0		
15	20	730	90,5	91,0	91,0	0,60	0,71	0,76	33,0	730	89,0	89,6	89,8	0,53	0,65	0,72	31,7		
18,5	25	730	89,8	90,1	90,1	0,67	0,78	0,83	37,6	735	89,8	90,3	90,3	0,60	0,73	0,80	35,6		
22	30	730	90,3	90,6	90,6	0,67	0,78	0,83	44,5	735	90,3	90,8	90,8	0,60	0,73	0,79	42,7		
30	40	725	91,0	91,3	91,3	0,70	0,80	0,85	58,7	730	91,0	91,5	91,5	0,63	0,75	0,85	53,7		
37	50	740	91,5	91,8	91,8	0,67	0,76	0,81	75,6	740	91,5	92,0	92,0	0,60	0,71	0,77	72,7		
45	60	740	91,9	92,2	92,2	0,67	0,76	0,80	92,7	740	91,9	92,4	92,4	0,60	0,71	0,78	86,9		
55	75	740	92,2	92,5	92,5	0,69	0,77	0,81	112	740	92,2	92,7	92,7	0,62	0,73	0,79	104		
75	100	740	92,8	93,1	93,1	0,69	0,77	0,81	151	740	92,8	93,3	93,3	0,62	0,73	0,79	142		
90	125	740	93,1	93,4	93,4	0,69	0,77	0,81	181	740	93,1	93,6	93,6	0,62	0,73	0,79	169		
110	150	740	93,4	93,7	93,7	0,68	0,77	0,81	220	740	93,4	93,9	93,9	0,61	0,72	0,78	209		
132	175	740	93,7	94,0	94,0	0,66	0,75	0,81	263	745	93,7	94,2	94,2	0,60	0,71	0,77	253		
160	220	745	94,0	94,3	94,3	0,68	0,78	0,82	314	745	94,0	94,5	94,5	0,61	0,73	0,79	298		
185	250	745	94,0	94,6	94,6	0,68	0,78	0,82	362	745	94,4	94,8	94,8	0,60	0,72	0,78	348		
200	270	745	94,3	94,6	94,6	0,69	0,79	0,82	392	745	94,3	94,8	94,8	0,61	0,73	0,78	376		
220	300	745	94,8	95,6	95,6	0,67	0,78	0,82	426	745	94,8	95,6	95,7	0,63	0,73	0,78	410		
250	340	745	95,5	95,8	95,8	0,67	0,77	0,81	489	745	94,7	95,5	95,7	0,58	0,70	0,77	472		
260	350	745	95,5	95,8	95,8	0,67	0,77	0,81	509	745	94,7	95,5	95,7	0,58	0,70	0,77	491		
280	380	745	95,5	95,9	95,9	0,66	0,76	0,81	548	745	94,7	95,5	95,7	0,57	0,70	0,77	529		
Optional frames & high output designs																			
37	50	700	91,5	91,8	91,8	0,64	0,75	0,81	75,6	735	91,5	92,0	92,0	0,57	0,70	0,77	72,7		
55	75	740	92,2	92,5	92,5	0,65	0,74	0,78	116	745	92,2	92,7	92,7	0,57	0,69	0,75	110		
110	150	740	93,4	93,7	93,7	0,68	0,77	0,81	220	740	93,4	93,9	93,9	0,61	0,72	0,78	209		
132	175	740	93,7	94,0	94,0	0,68	0,77	0,81	263	740	93,7	94,2	94,2	0,61	0,72	0,78	250		



**BIBUS**

**BIBUS s.r.o.**  
+420 547 125 300  
[www.bibus.cz](http://www.bibus.cz)



## W22 Super Premium

### Presenting the world's highest and widest efficiency level induction motor range

In the last two decades, global energy consumption has increased by 50% with forecast for that the next two decades will continue to see significant increases in this usage.

This increasing demand for electrical energy to sustain global development requires consistent heavy investments in power supply generation. However, in addition to complex medium and long term planning, these investments rely on natural resources, which are becoming depleted due to constant pressures upon the environment.

As a reflection of this scenario, electric energy costs are rising dramatically, and in comparison to other economic indicators, standing out negatively.

One of the main contributing factors to this increase in power consumption is in the industrial sector, which utilises around 30% of the electrical energy globally available. And, in industrial applications, electric motor driven systems represents around 68% of all energy consumption.

Furthermore, if we consider both industrial and domestic applications, including appliances in our analysis, electric motors account for more than 40% of the total energy consumed Globally.

This serves to emphasize the scale of worldwide electrical energy consumption by electric motors and the importance placed

upon development of more and more efficient products, not only to fulfil but to reduce this increasing demand, and consequently achieve energy / financial savings and emissions reduction.

In response to this situation, several Government Authorities are implementing Minimum Energy Efficiency Performance Standards, in order to encourage greater utilization of high-efficient equipment.

In Europe it was no different, and motor systems were earmarked as a priority target in the Eco-Design Directive (2005), which has established requirements for Energy-using Products: "EuP Directive". As a result, EU Mandatory Minimum Energy-Efficiency Performance Standard (MEPS) for industrial electric motors entered into force from July 2009.

With this situation in mind WEG presents its W22 Super Premium efficiency motor line, exceeding the IE4 Efficiency Levels defined in the IEC Standard 60034-30-1 from March 2014.

The efficiency performance of these motors far exceed the IE2 or IE3 minimum efficiency levels required in Europe today. This enables customers to reduce their Total Cost of Ownership through the reduction in energy consumption and consequently their carbon footprint.

High overall performance which is translated into a lower Total Cost of Ownership, due to its reliability, easy maintenance and energy savings!

## W22 - Super Premium Efficiency - IE4 <sup>(1)</sup>

Output		Frame	Full load torque (Nm)	Locked rotor current I/In	Locked rotor torque TI/Tn	Breakdown torque Tb/Tn	Inertia J (kgm <sup>2</sup> )	Allowable locked rotor time (s)		Weight (kg)	Sound dB (A)	Rated speed (rpm)	400 V						Full load current In (A)
								Hot	Cold				% of full load			Power factor			
													50	75	100	50	75	100	
II poles - 3000 rpm - 50 Hz																			
5,5	7,5	132S	17,9	7,9	2,6	3,4	0,0252	27	59	69,0	67	2940	89,0	90,6	90,9	0,71	0,81	0,86	10,2
7,5	10	L132S	24,4	8,3	2,7	3,4	0,0285	16	35	73,0	67	2940	90,3	91,5	91,7	0,69	0,80	0,86	13,7
9,2	12,5	L132M/L	30,0	8,7	2,7	3,4	0,0356	16	35	79,0	67	2935	91,0	91,9	92,2	0,72	0,82	0,87	16,6
11	15	160M	35,6	8,5	2,9	3,5	0,0588	14	31	120	67	2955	91,1	92,3	92,8	0,69	0,80	0,86	19,9
15	20	160M	48,5	8,2	2,9	3,5	0,0698	11	24	126	67	2955	92,1	93,0	93,3	0,70	0,81	0,86	27,0
18,5	25	160L	59,9	8,2	3,1	3,5	0,0841	10	22	144	67	2950	92,8	93,4	93,7	0,71	0,82	0,87	32,8
22	30	180M	71,1	8,2	2,7	3,4	0,1183	8	18	176	67	2955	93,3	93,8	94,0	0,73	0,82	0,87	38,8
30	40	200L	96,5	8,2	3,4	3,1	0,2119	16	35	265	69	2970	93,0	94,1	94,5	0,70	0,80	0,85	53,9
37	50	200L	119	8,1	3,4	3	0,2373	14	31	275	69	2970	93,6	94,5	94,8	0,72	0,82	0,86	65,5
45	60	225S/M	145	7,4	2,3	2,9	0,3641	17	37	425	74	2965	94,8	95,2	95,2	0,82	0,88	0,91	75,0
55	75	250S/M	177	8,2	3	3,1	0,6068	28	62	520	74	2970	94,6	95,3	95,5	0,81	0,88	0,90	92,4
75	100	280S/M	240	7,9	2,4	3,1	1,47	50	110	800	76	2980	95,1	96,0	96,3	0,80	0,87	0,90	125
90	125	280S/M	289	7,8	2,4	2,9	1,64	45	99	890	76	2980	95,5	96,2	96,5	0,82	0,88	0,90	150
110	150	315S/M	353	7,8	2,3	3	2,32	42	92	992	76	2980	94,9	95,9	96,5	0,79	0,86	0,89	185
132	175	315S/M	423	7,4	2,3	2,8	2,77	36	79	1095	76	2980	95,6	96,2	96,6	0,83	0,89	0,91	217
150	200	315S/M	481	7,6	2,4	2,9	3,20	42	92	1197	76	2980	96,0	96,6	96,8	0,82	0,88	0,90	249
160	220	315S/M	513	7,6	2,4	2,9	3,20	42	92	1197	76	2980	96,0	96,6	96,8	0,82	0,88	0,90	265
185	250	315L	593	7,9	2,6	2,8	3,50	29	64	1315	77	2980	95,9	96,5	96,8	0,84	0,89	0,91	303
200	270	315L	641	8,2	2,7	2,9	3,72	32	70	1345	77	2980	96,3	96,8	97,0	0,83	0,89	0,91	327
220	300	315L	705	8,1	2,7	2,7	3,95	25	55	1390	77	2980	96,3	96,7	96,9	0,85	0,90	0,92	356
250	340	315L	803	7,5	2,6	2,6	4,15	20	44	1434	77	2975	96,7	96,9	96,9	0,85	0,90	0,92	405
260	350	315L	835	7,5	2,6	2,6	4,15	20	44	1434	77	2975	96,7	96,9	96,9	0,85	0,90	0,92	421
280	380	355M/L	896	8,4	2,1	2,9	5,36	32	70	1664	80	2985	96,2	96,8	97,0	0,83	0,89	0,91	458
300	400	355M/L	960	7,5	2	2,6	5,68	32	70	1751	80	2985	96,5	96,9	97,0	0,86	0,91	0,92	485
315	430	355M/L <sup>(4)</sup>	1008	8,2	2,4	2,7	6,01	23	51	1838	80	2985	96,5	96,9	97,0	0,86	0,91	0,92	509
330	450	355A/B <sup>(4)</sup>	1056	8,2	2,4	2,6	6,33	24	53	2000	82	2985	96,7	97,0	97,1	0,89	0,92	0,93	527
355	480	355A/B <sup>(4)</sup>	1136	8,2	2,3	2,6	6,76	20	44	2043	82	2985	96,8	97,1	97,1	0,89	0,92	0,93	567
IV poles - 1500 rpm - 50 Hz																			
5,5	7,5	L132S	35,7	8,8	2,9	3,5	0,0640	16	35	78,0	56	1470	90,8	91,8	91,9	0,63	0,75	0,82	10,5
7,5	10	L132M/L	48,7	9,3	3,2	3,6	0,0791	14	31	84,0	56	1470	91,4	92,3	92,6	0,62	0,74	0,81	14,4
9,2	12,5	160M	59,4	8,6	3	3,3	0,1398	16	35	115	61	1480	91,9	92,9	93,0	0,61	0,74	0,81	17,6
11	15	160M	71,3	8,2	3	3,5	0,1537	14	31	125	61	1475	92,0	93,0	93,3	0,61	0,73	0,81	21,0
15	20	L160L	97,2	7,2	3	3,2	0,1813	28	62	150	61	1475	92,7	93,6	93,9	0,63	0,75	0,81	28,5
18,5	25	L180M	119	8,2	3	3,4	0,2291	16	35	185	61	1480	93,6	94,2	94,2	0,64	0,76	0,83	34,2
22	30	L180L	142	8,7	3,3	3,8	0,2594	14	31	200	61	1480	93,7	94,3	94,5	0,63	0,75	0,82	41,0
30	40	200L	193	7,4	2,8	3,2	0,3979	18	40	284	63	1485	93,9	94,7	94,9	0,60	0,73	0,81	56,3
37	50	225S/M	238	7,9	2,8	3,2	0,7346	21	46	430	63	1485	94,6	95,1	95,2	0,67	0,78	0,84	66,8
45	60	225S/M	290	8,3	2,9	3,3	0,7346	15	33	440	63	1485	94,2	95,0	95,4	0,62	0,74	0,82	83,0
55	75	250S/M	354	8,3	3	3,4	1,21	17	37	531	64	1485	94,9	95,4	95,7	0,66	0,78	0,83	100
75	100	280S/M	481	7,9	2,9	2,9	2,78	40	88	830	69	1490	95,5	96,1	96,2	0,72	0,81	0,85	132
90	125	280S/M	579	7,9	3	2,9	3,40	40	88	895	69	1485	95,9	96,3	96,4	0,73	0,82	0,86	157
110	150	315S/M	705	7,4	2,7	2,7	4,42	54	119	1150	71	1490	95,8	96,4	96,8	0,73	0,82	0,86	191
132	175	315S/M	846	7,5	2,8	2,7	5,29	50	110	1332	71	1490	96,1	96,7	96,9	0,73	0,82	0,86	229
150	200	315L	962	7,7	3	2,6	5,73	40	88	1430	72	1490	96,3	96,8	96,9	0,74	0,83	0,86	260
160	220	315L	1026	7,7	3	2,6	5,73	40	88	1430	72	1490	96,3	96,8	96,9	0,74	0,83	0,86	277
185	250	315L	1186	7,7	3	2,6	6,17	32	70	1480	72	1490	96,4	96,8	96,9	0,74	0,83	0,86	320
200	270	315L	1283	7,9	3	2,7	6,51	31	68	1527	72	1490	96,4	96,9	97,0	0,74	0,83	0,86	346
220	300	355M/L	1411	7,9	2,6	2,8	8,95	36	79	1670	74	1490	95,9	96,6	96,9	0,72	0,81	0,85	386
250	340	355M/L	1603	8,2	2,7	2,8	10,0	33	73	1730	74	1490	96,1	96,7	97,0	0,72	0,81	0,85	438
260	350	355M/L	1667	8,2	2,7	2,8	10,0	33	73	1730	74	1490	96,1	96,7	97,0	0,72	0,81	0,85	455
280	380	355M/L	1796	7,9	2,7	2,7	10,5	28	62	1772	74	1490	96,3	96,8	97,0	0,72	0,81	0,85	490
300	400	355M/L	1924	7,8	2,7	2,6	11,1	24	53	1825	74	1490	96,4	96,8	97,0	0,73	0,82	0,86	519
315	430	355M/L	2020	7,8	2,9	2,6	11,6	27	59	1878	74	1490	96,5	96,9	97,0	0,73	0,82	0,86	545
330	450	355A/B <sup>(4)</sup>	2116	7,3	2,5	2,4	12,5	28	62	2062	76	1490	96,7	97,0	97,0	0,77	0,84	0,87	564
355	480	355A/B <sup>(4)</sup>	2277	7,6	2,8	2,5	13,5	23	51	2089	76	1490	96,7	97,0	97,0	0,75	0,83	0,87	607

Note:

(1) Efficiency values are given according to IEC 60034-2-1. They are calculated according to indirect method, with stray load losses determined by measurement.  
 (4) Fitted with air deflector in the drive end side.

**W22 - Super Premium Efficiency - IE4 <sup>(1)</sup>**

Output		Frame	Full load torque (Nm)	Locked rotor current I <sub>L</sub> /I <sub>n</sub>	Locked rotor torque T <sub>L</sub> /T <sub>n</sub>	Breakdown torque T <sub>b</sub> /T <sub>n</sub>	Inertia J (kgm <sup>2</sup> )	Allowable locked rotor time (s)		Weight (kg)	Sound dB (A)	Rated speed (rpm)	400 V						Full load current I <sub>n</sub> (A)
								Hot	Cold				% of full load			Power factor			
													50	75	100	50	75	100	
VI poles - 1000 rpm - 50 Hz																			
3	4	132S	29,6	6,3	1,8	2,5	0,0568	48	106	61,0	52	970	88,0	89,3	88,6	0,53	0,66	0,73	6,69
4	5,5	132M	39,4	6,6	2	2,6	0,0643	35	77	68,0	52	970	88,5	89,6	89,5	0,53	0,66	0,73	8,84
5,5	7,5	L132M/L	53,9	7,3	2,5	3	0,0833	27	59	84,0	52	975	88,7	90,1	90,5	0,50	0,63	0,71	12,4
7,5	10	160M	73,1	6,8	2,6	2,9	0,1931	21	46	130	56	980	90,6	91,5	91,3	0,60	0,73	0,80	14,8
9,2	12,5	160L	89,7	7,1	2,5	2,9	0,2370	23	51	148	56	980	91,0	91,6	91,8	0,63	0,75	0,81	17,9
11	15	160L	107	7,3	2,9	3,2	0,2370	14	31	150	56	980	90,3	91,5	92,3	0,55	0,68	0,77	22,3
15	20	180L	146	8,2	2,8	3,4	0,3765	13	29	210	56	980	92,0	92,6	92,9	0,63	0,75	0,82	28,4
18,5	25	200L	180	6,6	2,4	2,7	0,4896	23	51	235	60	980	92,7	93,2	93,4	0,63	0,75	0,81	35,3
22	30	200L	213	7,0	2,6	2,9	0,5246	18	40	250	60	985	92,4	93,2	93,7	0,59	0,72	0,79	42,9
30	40	225S/M	291	7,4	2,4	2,8	1,02	23	51	430	63	985	93,7	94,1	94,2	0,69	0,80	0,84	54,7
37	50	250S/M	359	7,3	2,6	2,8	1,65	30	66	520	64	985	94,3	94,7	94,5	0,70	0,81	0,85	66,5
45	60	280S/M	434	7,0	2,3	2,8	3,25	35	77	723	65	990	94,4	95,0	95,2	0,65	0,76	0,82	83,2
55	75	280S/M	531	7,2	2,6	3	3,92	36	79	740	65	990	94,6	95,3	95,4	0,64	0,75	0,81	103
75	100	315S/M	724	6,8	2,3	2,7	7,25	60	132	1106	67	990	95,3	96,0	96,2	0,67	0,77	0,82	137
90	125	315S/M	869	6,7	2,2	2,4	7,96	48	106	1180	67	990	95,7	96,1	96,2	0,69	0,79	0,83	163
110	150	315L	1058	6,9	2,5	2,6	9,04	44	97	1320	68	993	95,7	96,2	96,3	0,67	0,77	0,82	201
132	175	315L	1274	7,2	2,6	2,7	9,95	36	79	1384	68	990	95,9	96,3	96,4	0,67	0,77	0,82	241
150	200	315L	1448	7,2	2,7	2,6	11,0	30	66	1448	68	990	95,9	96,3	96,4	0,67	0,78	0,83	271
160	220	315L	1544	7,2	2,7	2,6	11,0	30	66	1448	68	990	95,9	96,3	96,5	0,67	0,78	0,83	288
185	250	355M/L	1777	6,6	2,1	2,4	13,2	50	110	1854	73	995	95,8	96,4	96,5	0,64	0,75	0,81	342
200	270	355M/L	1921	6,6	2,2	2,3	14,1	48	106	1912	73	995	95,8	96,4	96,5	0,64	0,75	0,81	369
220	300	355M/L	2123	6,5	2,1	2,3	15,0	48	106	1970	73	990	95,9	96,5	96,5	0,65	0,76	0,81	406
250	340	355A/B <sup>(4)</sup>	2413	6,5	2,2	2,3	17,1	42	92	2246	73	990	96,1	96,5	96,6	0,66	0,76	0,82	456
260	350	355A/B <sup>(4)</sup>	2509	6,5	2,2	2,3	17,1	42	92	2246	73	990	96,1	96,5	96,6	0,66	0,76	0,82	474
280	380	355A/B <sup>(4)</sup>	2702	6,6	2,3	2,3	18,0	35	77	2300	73	990	95,8	96,4	96,6	0,64	0,75	0,81	517
300	400	355A/B <sup>(4)</sup>	2895	6,5	2,2	2,3	18,9	35	77	2346	73	990	95,9	96,4	96,6	0,65	0,76	0,81	553
315	430	355A/B <sup>(4)</sup>	3040	6,7	2,4	2,3	18,9	31	68	2346	73	990	95,7	96,3	96,6	0,63	0,74	0,80	588
Optional frames & high output designs																			
110	150	315S/M	1058	6,9	2,5	2,6	7,23	44	97	1106	67	993	95,7	96,2	96,2	0,67	0,77	0,82	201

Note:

(1) Efficiency values are given according to IEC 60034-2-1. They are calculated according to indirect method, with stray load losses determined by measurement.

(4) Fitted with air deflector in the drive end side.

## 18. Mechanical Data

### Foot Mounted Motors, Terminal Box Top

#### Frames 63 to 132M/L

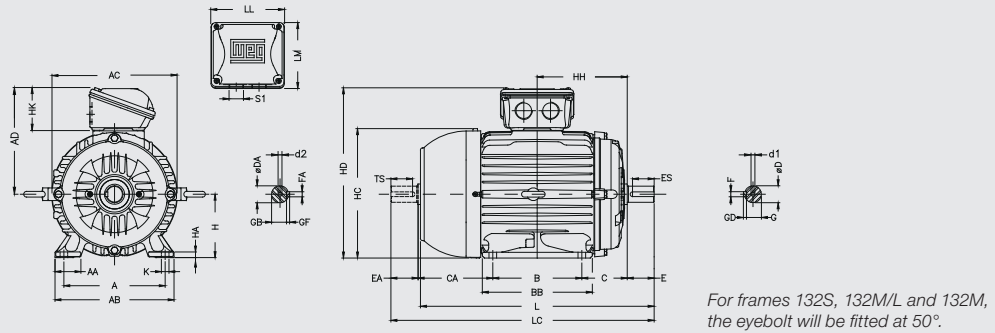

#### Frames 160M to 200L

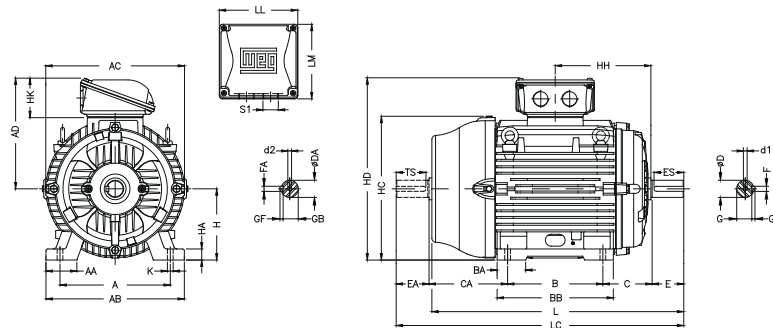

#### Frames 225 to 355M/L\*

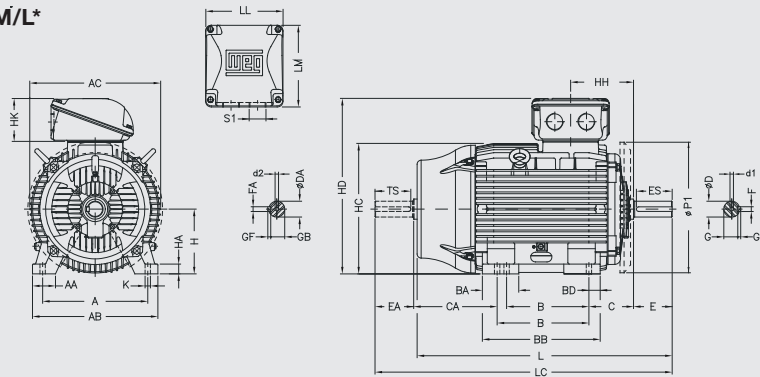

#### Frame 355A/B\*

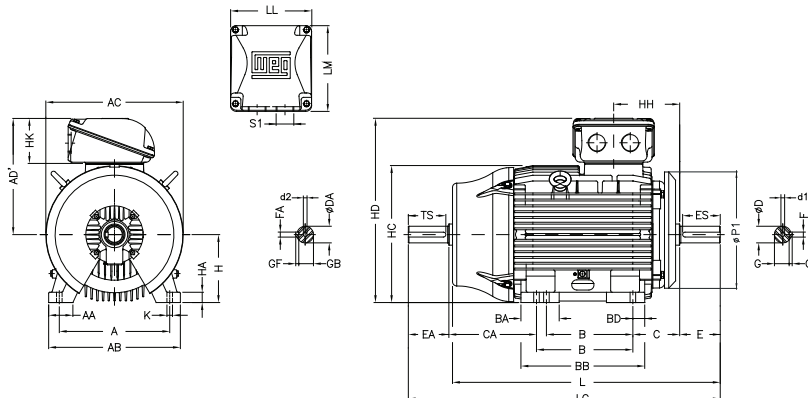

\* Some outputs in frame sizes 315 and 355 are equipped with an air deflector at the DE. In this case the dimension P1 will be 780mm and 880mm for frames 315 and 355 respectively.



Frame	A	AA	AB	AC	AD	B	BA	BB	BD	C	CA	Shaft											
												D	E	ES	F	G	GD	DA	EA	TS	FA	GB	GF
63	100	25,5	116	133	126	80		95		40	78	11j6	23	14	4	8,5	4	9j6	20	12	3	7,2	3
71	112	28,5	132	141	133	90		113,5		45	88	14j6	30	18	5	11	5	11j6	23	14	4	8,5	4
80																							
L80	125	30,7	149	159	142	100		125,5		50	93	19j6	40	28	6	15,5	6	14j6	30	18		11	
90S																							
L90S																							
90L	140	36,5	164	184	159	125		131		56	104	24j6	50	36			7	16j6	40	28	5	13	5
L90L																							
100L																							
L100L	160	40	188	206	172	140		173		63	118	28j6	60	45	8		7	22j6	50	36	6	18,5	6
112M																							
L112M	190	40,5	220	227	203	177		177		70	128	28j6	60	45				24j6	50	36		20	
132S																							
132M	216	45	248	274	222	178		225		89	150	38k6	80	63	10	33	8	28j6	60	45	8	24	7
L132M/L						178/203		250															
160M																							
L160M	254	64	308	329	272	210	63	254		108	174	42k6			12	37		42k6			12	37	8
180M																							
L180M	279	78	350	360	287	241	70	294		121	200	48k6	110	80			9	48k6	110	80			
200M																							
L200M	318	82	385	402	326,5	267	82	332		133	222	55m6			16	49	10				14	42,5	9
200L						305		370															
225S/M	356	80	436	455	381	286/311	124	412	41	149	319/294	55m6*	110*	100*	16*	49*	10*	55m6*	110*	100*	16*	49*	10*
250S/M	406		506	486	396	311/349	146	467	59	168	354/316	60m6*	140	125	18	53	11	60m6					
280S/M	457	100	557	599	451	368/419	151	517	49	190	385/334	65m6*	140	125	18*	58*	11*	60m6*					
315S/M																							
L315S/M	508	120	630	657	505	406/457	184	621	70	216	494*/443	75m6*	140*	125*	18*	58*	11*	60m6*	140	125	18	53*	11
315L																							
L315L																							
355M/L																							
L355M/L	610	140	750	736	588	560/630	230	760	65	254	483/413	80m6	170	160	22	71	14	65m6	140*	125*	18*	53*	11*
355A/B																							
L355A/B																							

Frame	H	HA	HB	HC	HD	HF	HG	HH	HK	LL	LM	K	L	LC	S1	d1	d2	Bearing	
																		DE	NDE
63	63		25,5	130	189	68,5		80				7	216	241		EM4	EM3	6201 ZZ	
71	71	7	33	145	204	76		90					250	276	2xM20x1.5	DM5	EM4	6202 ZZ	
80																			
L80	80	8	43,5	163	222	87		100	59	108,5	99		277	313		DM6	DM4	6204 ZZ	6203 ZZ
90S																			
L90S																			
90L	90	9	45	182	249	90		106				10	304	350					
L90L																			
100L																			
L100L	100	10	61,5	205	272	106,4		118,5	67	115	104		335	381	2xM25x1.5	DM8	DM6	6205 ZZ	6204 ZZ
112M																			
L112M	112		54,5	235	315	112		133				12	329	375					
132S																			
L132M	132	17	75	274	354	132		140					360	406					
L132M/L																			
160M																			
L160M	160	22	79	331	432	168		159	80	140	133		418	475	2xM32x1.5	DM12	DM10	6308 ZZ	6207 ZZ
180M																			
L180M	180	28	92	366	467	180		178											
200M																			
L200M	200	30	119	407	526,5	218		190,5											
225S/M	225	34	254	453	606	421	534	212				14,5	452	520,5	2xM40x1.5	DM16			
250S/M	250	43	297	493	646	463	577	214											
280S/M	280	42	386	580	731	572	686	266	151	314	312		515	582					
315S/M																			
L315S/M	315	48	386	644	820	592	751	264	176	379	382	18,5	598	712	2xM50x1.5				
315L																			
L315L																			
355M/L																			
L355M/L	355	50	461	723	943	700	885	339	220	404	436	24	642	756					
355A/B																			
L355A/B																			

Notes:  
(\*) Dimension applicable to 2 pole motors.

**Foot mounted motors, Terminal Box Left or Right Side**

**Frames 63 to 132M/L**

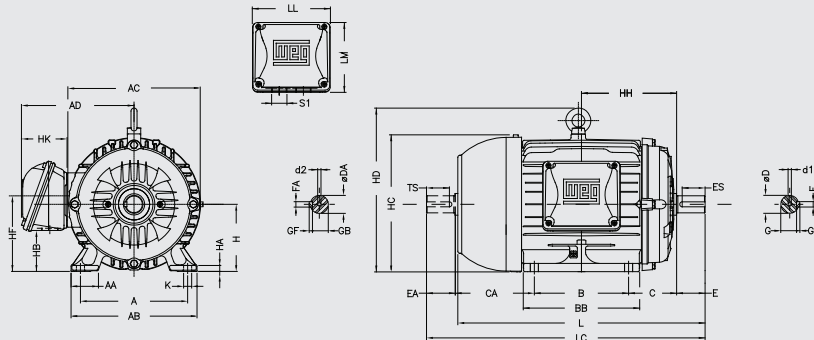

**Frames 160M to 200L**

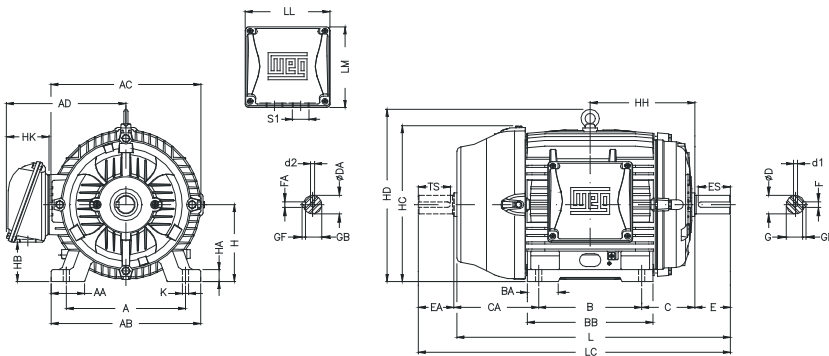

**Frames 225 to 355M/L\***

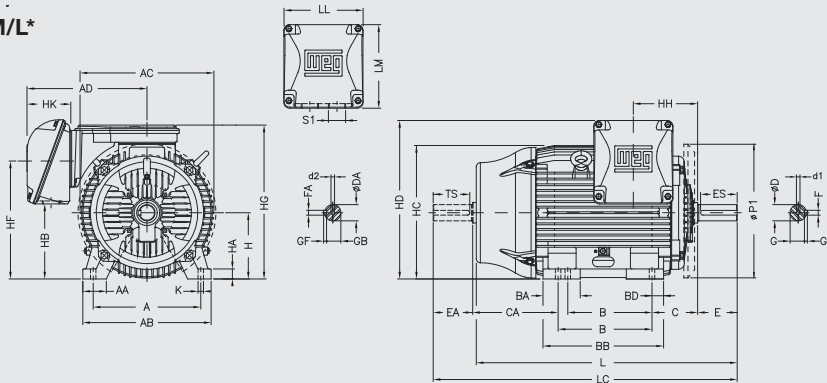

**Frame 355A/B\***

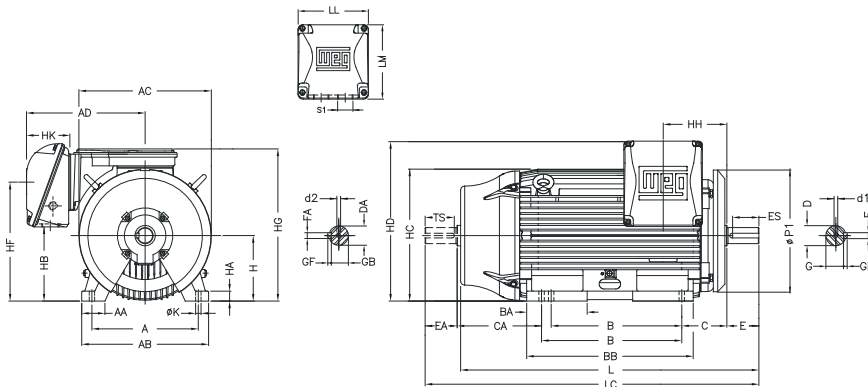

\* Some outputs in frame sizes 315 and 355 are equipped with an air deflector at the D.E. In this case the dimension P1 will be 780mm and 880mm for frames 315 and 355 respectively

Frame	A	AA	AB	AC	AD	B	BA	BB	BD	C	CA	Shaft											
												D	E	ES	F	G	GD	DA	EA	TS	FA	GB	GF
63	100	25,5	116	133	123	80		95		40	78	11j6	23	14	4	8,5	4	9j6	20	12	3	7,2	3
71	112	28,5	132	141	131	90		113,5		45	88	14j6	30	18	5	11	5	11j6	23	14	4	8,5	4
80	125	30,7	149	159	140	100		125,5		50	93 142	19j6	40	28	6	15,5	6	14j6	30	18	5	11	4
L80																							
90S	140	36,5	164	184	159	125		156		56	104 135 104 135	24j6	50	36	8	20	7	16j6	40	28	5	13	5
L90S																							
90L																							
L90L																							
100L	160	40	188	206	169	140		173		63	118 162	28j6	60	45			22j6	50	36	6	18,5	6	
L100L																							
112M	190	40,5	220	227	192	177		187		70	128 158						24j6	50	36	8	20	7	
L112M																							
132S	216	45	248	274	220	250		225		89	150	38k6	80	63	10	33	8	28j6	60	45	8	24	7
L132M																							
132M/L	254	64	308	329	266	298	63	254		108	174	42k6					8	42k6			12	37	8
160M																							
160L	279	78	350	360	281	294	70	294		121	200	48k6	110	80	14	42,5	9	48k6	110	80	14	42,5	9
180M																							
180L	318	82	385	402	319	370	82	370		133	222	55m6			16	49	10				16	49	10
200M																							
200L	356	80	436	455	410	294	124	412	41	149	319/294	55m6* 60m6	110*	100*	16*	49*	10*	55m6*	110*	100*	16*	49*	10*
225S/M																							
250S/M	406	100	506	486	445	311/349	146	467	59	168	354/316	60m6*	140	125	18	53*	11	60m6			18	53*	11
280S/M																							
280S/M	457	557	599	445	368/419	151	517	49	190	385/334	75m6	65m6*	140*	125*	18*	58*	11*	60m6*	140	125	18	53*	11*
315S/M																							
315S/M	508	120	630	657	525	406/457	184	621	70	216	494*/443	65m6*	140*	125*	18*	58*	11*	60m6*			14	42,5	9
315L																							
355M/L	610	140	750	736	609	560/630	230	760	65	254	483/413	75m6*	140*	125*	20*	67,5*	12*	60m6*	140*	125*	18*	53*	11*
355A/B																							
355A/B	701	710/800	325	955	70	528/438						75m6*	140*	125*	20*	67,5*	12*	60m6*	140*	125*	18*	53*	11*
100m6																							

Frame	H	HA	HB	HC	HD	HF	HG	HH	HK	LL	LM	K	L	LC	S1	d1	d2	Bearing																		
																		DE	NDE																	
63	63	7	25,5	130	156,3	68,5		80	59	108,5	99	7	216	241	2xM20x1.5	EM4	EM3	6201 ZZ																		
71	71																	33	145	163,8	76	90	250	276	DM5	EM4	6202 ZZ									
80	80	8	43,5	163	174,3	87		100				10	277	313		DM6	DM4	6204 ZZ	6203 ZZ																	
L80																		325	360																	
90S	90	9	45	182	182,4	90		106				12	304	350		DM8	DM6	6205 ZZ	6204 ZZ																	
L90S																		335	381																	
90L																		329	375																	
L90L																		360	406																	
100L	100	10	61,5	205	243,5	106,4		133				12	376	431		DM10	DM8	6206 ZZ	6205 ZZ																	
L100L																		418	475																	
112M	112		54,5	235	280	112		140				12	394	448		DM10	DM8	6207 ZZ	6206 ZZ																	
L112M																		423	478																	
132S	132	17	75	274	319	132		159	80	140	133	12	452	520,5	2xM32x1.5	DM12	DM10	6308 ZZ	6207 ZZ																	
L132M																		489	557																	
160M	160	22	79	331	374	168		190,5				18,5	515	582		DM16	DM16	6309 C3	6209 Z-C3																	
160L																		213	712																	
180M	180	28	92	366	413	180		235	101	198,5	190	14,5	642	756	2xM40x1.5	DM16	DM16	6311 C3	6211 Z-C3																	
180L																		241,5	782																	
200M	200	30	119	407	464	218		260,5	119,5	230	220	18,5	702	820		DM20	DM20	6312 C3	6212 Z-C3																	
200L																		266,5	842																	
225S/M	225	34	254	453	541	421	534	212	153	269	285	24	767	880	2xM50x1.5	DM20	DM20	6314 C3																		
250S/M																		856*	974*																	
280S/M	280	42	386	580	700	572	686	266	151	314	312	24	886	1034		DM20	DM20	6314 C3*																		
315S/M																		965	1113																	
315S/M	315	48	386	644	768	592	751	264	176	379	382	28	1071	1223	2xM63x1.5	DM20	DM20	6316 C3																		
315L																		1274	1426																	
355M/L	355	50	461	723	898	700	885	339	220	404	436	28	1353*	1506*		DM20*	DM20*	6319 C3	6316 C3																	
355A/B																		1389	1536																	
355A/B	355	50	411	955	700	885	340	290	460	544		28	1412*	1577*		DM20*	DM20*	6319 C3	6316 C3																	
1607*																		1772*																		
1677	1872																																			

Notes:  
(\* Dimension applicable to 2 pole motors.)

**Flange Mounted Motors**

**“FF” Flange**

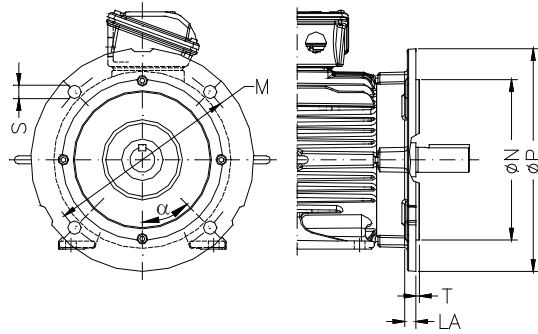

Flange “FF”											
Frame	Flange	LA	M	N	P	S	T	α	N° of holes		
63	FF-115	5,5	115	95	140	10	3	45°	4		
71	FF-130	7	130	110	160		3				
80	FF-165	9	165	130	200	12	3,5				
90		10									
100	FF-215	12,5	215	180	250	15	4				
112	FF-265	12	265	230	300						
160	FF-300	18	300	250	350	19	5				
180										FF-350	350
200	FF-400	18	400	350	450	24	6			22°30'	8
225	FF-500		500	450	550						
250	FF-600		22	600	550			660/780(*)			
280				740	680			800/880(*)			
315	FF-740	740	680	800/880(*)	800/880(*)						

\*Only for motors fitted with air deflector in drive end side.

**“C-DIN” Flange**

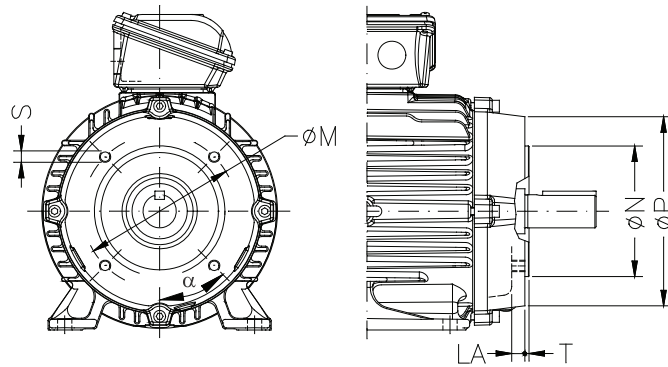

Frame	Flange	LA	M	N	P	S	T	α	N° of holes
63	C-90	9,5	75	60	90	M5	2,5	45°	4
71	C-105	8	85	70	105	M6			
80	C-120	10,5	100	80	120		M8		
90	C-140		115	95	140				
100	C-160	12	130	110	160	M10	3,5		
112		13,5							
132	C-200	15,5	165	130	200	M10	6,3		
160	C-250	19	215	180	249	M12x1,75			

“NEMA C” Flange

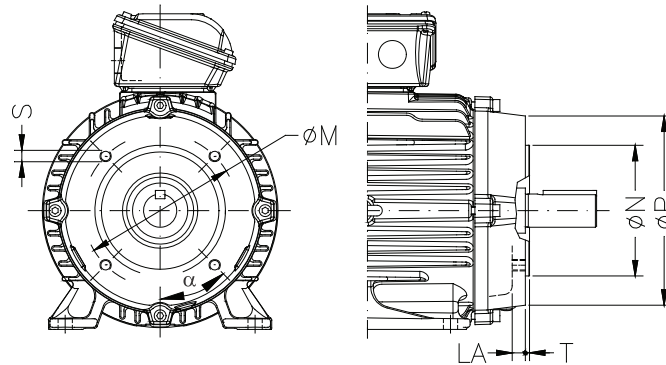

Flange “C”									
Frame	Flange	LA	M	N	P	S	T	α	N° of holes
63	FC-95	4.5	95.2	76.2	143	UNC 1/4"x20	4	45°	4
71		10							
80		15							
90	FC-149	12	149.2	114.3	165	UNC 3/8"x16			
100		13.5							
112		9							
132	FC-184	19.5	184.2	215.9	225	UNC 1/2"x13	6.3		
160		13.5							
180		9							
200	FC-228	13.5	228.6	266.7	280	UNC 5/8"x11	22°30'	8	
225		18.5							
250		279.4							317.5
280	FC-355	18.5	355.6	406.4	455	UNC 5/8"x11	22°30'	8	
315			368.3	419.1					
355	FC-368	33.5	368.3	419.1					



## 19. Terminal Box Drawings

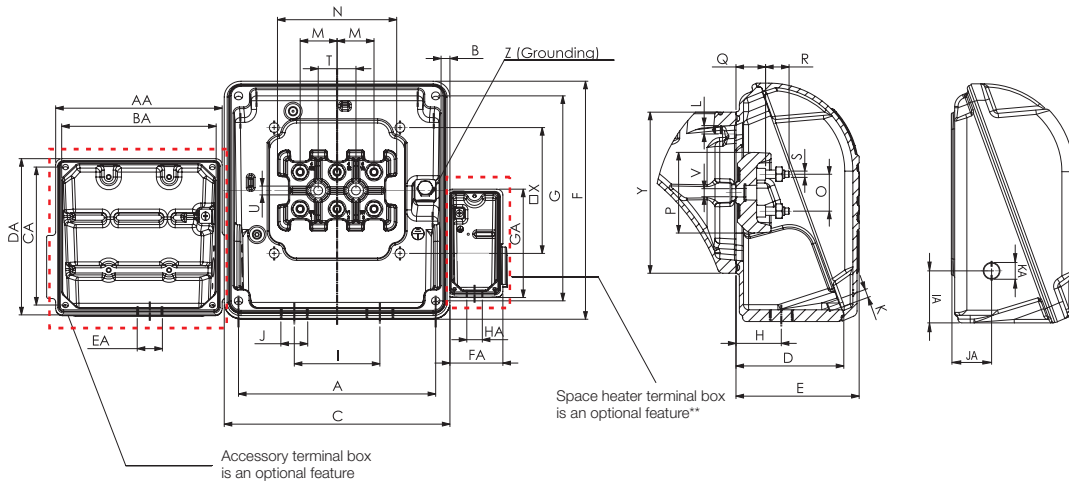

Frame	A	B	C	D	E	F	G	H	I	J	K	L	M	N	O	P	Q	R	S	T	U
63																					
71	90	3.5	108.5	51.5	59	99	85	27		2xM20x1.5	M5x0.8	M5x0.8	16	75	16	35	13.5	12	M4x0.7	20	5.8
80																					
90	98	3	115	59.5	67	104	91	31		2xM25x1.5											
100																					
112	117	2.5	140	71	80	133	117	36.5	54	2xM32x1.5	M6x1.0	M6x1.0	23		23	52	17	16	M5x0.8	23	6.5
132																					
160	175	4	198.5	90	101	190	175	46	84	2xM40x1.5	M8x1.25	M8x1.25	28	90	28	60	21.5	20.5	M6x1	28	6.6
180																					
200	204	4.5	230	107	119.5	220	204	59	94	2xM50x1.5			35	112	35	74	24	24	M8x1.25	35	9.5
225S/M	235	12.5	269	133	153	285	260	71	110	2xM63x1.5	M10x1.5	M10x1.5	44	140	44	94	28	28	M10x1.5	45	10.5
250S/M					147	312	275														
280S/M	275	13.5	314		176	382	345	78	160		M12x1.75	M12x1.75	45	153	45	108	34	40	M12x1.75	65	10.5
315S/M	340		379	162	176	382	345	78	160												
315L	365	14.5	404	202	220	436	390	97	200	2xM80x2	M10x1.5	M12x1.75	65	210	65	146	48	48	M16x2.0	65	10.5
355M/L																					
355A/B	415	-	460	267 232*	290	544	678	187 152(*)	140		M10x1.5	M12x1.75	80	-	105	-	-	-	M20x2.5	-	-

Frame	V	X	Y	Z	AA	BA	CA	DA	EA	FA	GA	HA	IA	JA	KA	Max number of connectors		
																Main	Accessories	Space heater
63			77	0.5-6 mm <sup>2</sup>	109	90	85	98	M20x1.5	68	101.4	M20x1.5	23	17.5	M20x1.5	4	16	4
71			78															
80	M5x0.8	56	81															
90			77															
100			81															
112		70	107	2-10 mm <sup>2</sup>	139	117	117	133	M20x1.5	68	M20x1.5	47	40	M20x1.5	12	26	4	
132		103																
160	M6x1.0	110	140	5.2-25 mm <sup>2</sup>	198	175	175	189	M20x1.5	68	131.2	M20x1.5	47	45	M20x1.5	12	26	4
180																		
200	M8x1.25	120	155															
225S/M	M10x1.5	150	192	25-50 mm <sup>2</sup>	198	175	175	189	M20x1.5	68	131.2	M20x1.5	62	48	M20x1.5	12	26	4
250S/M			197															
280S/M			204	35-70 mm <sup>2</sup>														
315S/M			200															
315L			260	85-120 mm <sup>2</sup>														
355M/L	300																	
355A/B	4xM6x1,5	290	290									57	95					

Notes:

(\*) Dimension is applicable to top, right or left terminal box mounting

(\*\*) Space heater terminal box is a special feature for frame sizes 63 to 112.

## 20. Drip Cover Data

Utilization of a drip cover / impact canopy increases the total length of the motor. The additional land length can be seen at table 22.

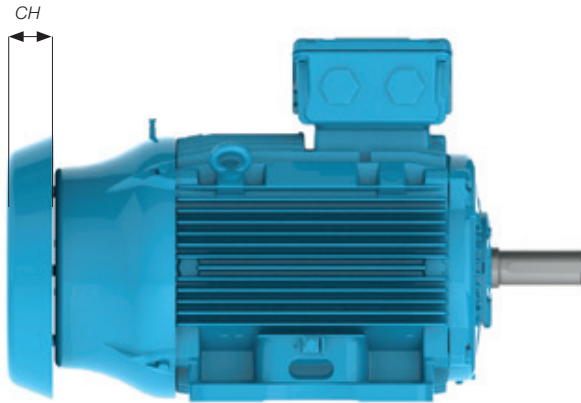

Figure 34 - Motor with drip cover

Frame	Dimension CH (increase motor length (mm))
63	18
71	
80	
90	
100	
100	28
112	31
132	
160	
180	47
200	67
225S/M	81
250S/M	
280S/M	
315S/M	
315L	91
355M/L	
355A/B	
355A/B	

Table 22 - Drip cover dimensions

## 21. External Motor Dimensions with Forced Ventilation

The use of forced ventilation increases the overall motor length, according to the table below.

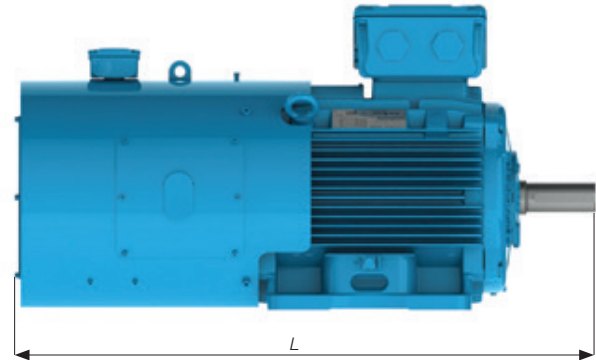

Figure 35 - Motor with forced ventilation

Frame size	Poles	Total motor length in mm (L)	
		Without forced ventilation	With forced ventilation
90S	All	304	548
L90S	All	335	579
90L	All	329	573
L90L	All	360	604
100L	All	376	646
L100L	All	418	690
112M	All	394	660
L112M	All	423	690
132S	All	452	715
132M	All	489	753
132M/L	All	515	778
160M	All	598	855
160L	All	642	899
180M	All	664	908
180L	All	702	946
200M	All	729	976
200L	All	767	1014
225S/M	2	856	1140
	4/8	886	1170
250S/M	2	965	1217
	4/8	965	1217
280S/M	2	1071	1348
	4/8	1071	1348
315S/M	2	1244	1459
	4/8	1274	1489
315L	2	1353	1568
	4/8	1389	1598
355M/L	2	1412	1786
	4/8	1482	1856
355A/B	2	1607	1981
	4/8	1677	2051

Table 23 - Forced ventilation dimensions

## 22. Silencer

The silencer for W22 motors reduces the noise level up to 5 dB(A), and it is available on 225–355 frames for foot-mounted and flange-mounted motors.

It is made of 2 mm steel or stainless steel plate and is internally covered by a sound absorbing material. For foot-mounted the silencer fits loosely over the motor, and has a rubber strip to seal against the floor.

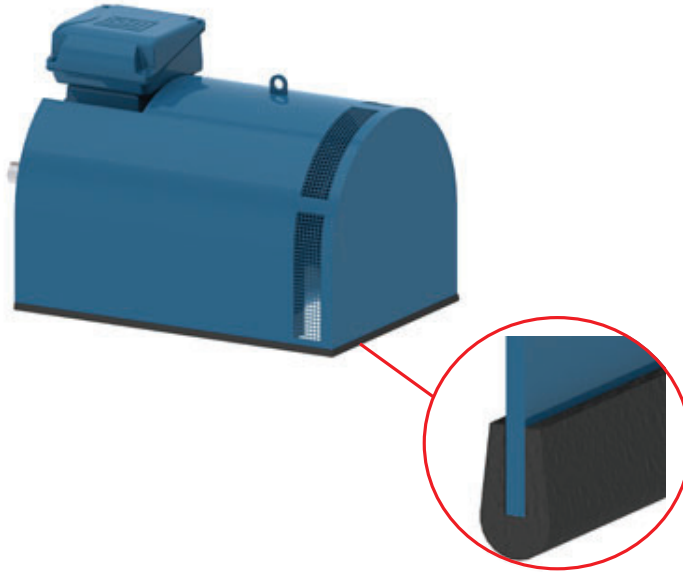
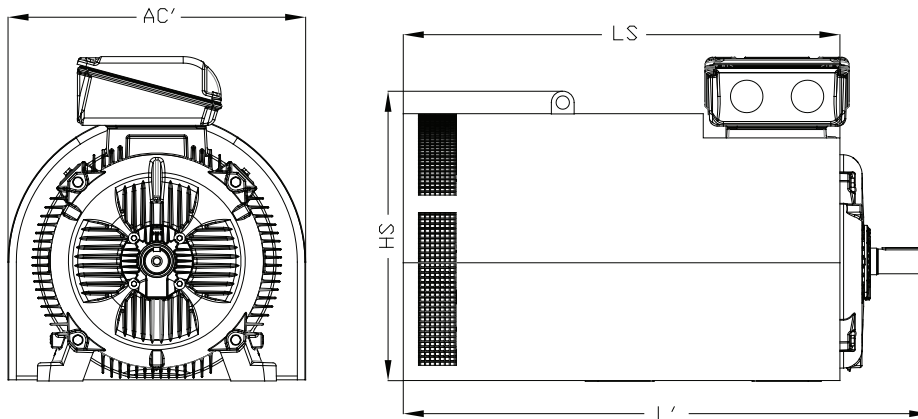

Figure 36 - Silencer for W22 motors.

### Silencer dimensional



Frame	AC'	L'	LS	HS
225S/M	564	955*	760	567
		985		
250S/M	604	1065	830	612
280S/M	704	1205	950	687
315S/M	784	1387*	1150	762
		1417		
355M/L	854	1587*	1305	834
		1657		
355A/B	854	1782*	1500	834
		1852		

\* Dimension for 2-pole motors.

Table 24 - Silencer dimensional



## 23. Packaging

### 23.1 Frames 63 to 132

W22 motors in frames 63 to 132 are packaged in cardboard boxes (see figure 37), following the dimensions, weights and volumes of the tables 25 and 26.



Figure 37 - Cardboard box

Frame	External height (m)	External width (m)	External length (m)	Weight (kg)	Volume (m <sup>3</sup> )
63	0.26	0.21	0.30	0.2	0.02
71					
80	0.32	0.27	0.43	0.9	0.04
L80					
90S					
90L					
L90S	0.33	0.27	0.46	1.4	0.04
100L					
L100L	0.36	0.30	0.46	1.5	0.05
112M					
L112M	0.42	0.33	0.60	1.5	0.08
132S					
132M					
132M/L	0.42	0.33	0.60	1.7	0.08

Table 25 - Cardboard box dimensions, weights and volumes for top mounting.

Frame	External height (m)	External width (m)	External length (m)	Weight (kg)	Volume (m <sup>3</sup> )
63	0.20	0.24	0.28	0.2	0.01
71	0.20	0.28	0.30	0.2	0.01
80	0.21	0.28	0.36	0.7	0.02
L80	0.24	0.32	0.40	0.8	0.03
90S					
90L					
L90L	0.26	0.34	0.43	1.0	0.04
100L	0.27	0.35	0.46	1.6	0.04
L100L	0.32	0.37	0.50	1.4	0.06
112M	0.31	0.38	0.46	1.7	0.05
L112M	0.31	0.38	0.53	1.5	0.06
132S	0.35	0.48	0.60	2.1	0.10
132M					
132M/L					

Note: Values to be added to the net motor weight.

Table 26 - Cardboard box dimensions, weights and volumes for side mounting.

### 23.2 Frames 160 to 355A/B

For frames 160 to 355A/B, the motors are packaged in wooden crates (see figure 38). Dimensions, weights and volumes are in tables 27 and 28.



Figure 38 - Wooden crates

Frame	External height (m)	External width (m)	External length (m)	Weight (kg)	Volume (m <sup>3</sup> )
160	0.50	0.40	0.74	9.2	0.15
180	0.53	0.43	0.82	12.3	0.19
200	0.59	0.51	0.88	13.5	0.27
225S/M	0.90	0.85	1.15	51.9	0.88
250S/M	0.90	0.85	1.25	54.6	0.96
280S/M	1.13	0.85	1.40	67.9	1.34
315S/M	1.13	0.85	1.55	69.9	1.49
315L	1.20	0.90	1.70	111	1.84
355M/L	1.32	1.05	1.73	127	2.40
355A/B	1.32	1.05	1.90	141	2.63

Table 27 - Wooden crates dimensions, weights and volumes for top mounting.

Frame	External height (m)	External width (m)	External length (m)	Weight (kg)	Volume (m <sup>3</sup> )
160	0.40	0.51	0.74	9.85	0.15
180	0.45	0.57	0.82	13.42	0.21
200	0.49	0.63	0.88	14.58	0.27
225S/M	0.78	0.85	1.15	47.70	0.76
250S/M	0.90	0.85	1.25	52.20	0.96
280S/M	0.95	0.95	1.40	71.60	1.26
315S/M	1.13	1.10	1.75	88.40	2.18
315L	1.10	1.12	1.70	138.37	2.10
355M/L	1.20	1.19	1.72	146.00	2.46
355A/B	1.20	1.19	1.90	163.00	2.71

Note: Values to be added to the net motor weight.

Table 28 - Wooden crates dimensions, weights and volumes for side mounting.

## 24. Spare Parts

### General Information

The following information is required when purchasing of spare parts:

- Serial number and manufacturing date, both stamped in the nameplate
- Spare part description
- Codes shown are for reference only. Final codes of spare parts will depend on colour

### Spare Parts Available 63-112

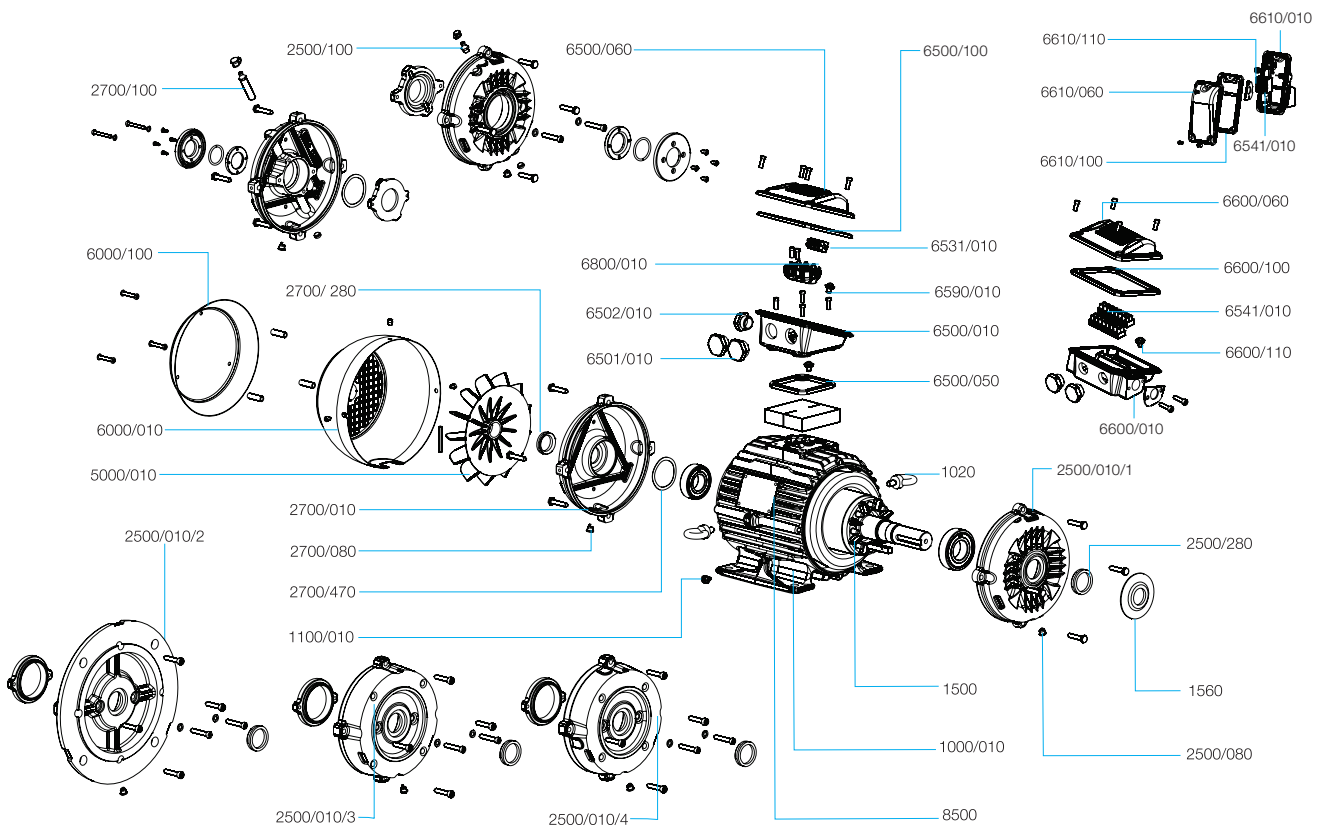

Component		Spare part	
Item	Description	Item	Composition
1000/010	Frame with wound stator	1000	Frame with wound stator
1020	Lifting eyebolt	1020	Lifting eyebolt
1100/010	Earthing terminal	1100	Earthing terminal
1500	Rotor, complete with shaft and key	1500	Rotor, complete with shaft and key
1560	Slinger	1560	Slinger (recommended for vertical shaft up applications, non-flange mounted)
2500/010/1	Endshield, drive end	2500/1	Endshield, drain plug, shaft seal, bolts and washers
2500/080	Drain plug, drive end		
2500/100	Grease nipple, drive end (2)		
2500/280	Shaft seal, drive end (1)		
2500/010/2	FF Flange	2500/2	FF Flange, drain plug, shaft seal, bolts and washers
2500/080	Drain plug, drive end		
2500/100	Grease nipple, drive end (2)		
2500/280	Shaft seal, drive end (1)		
2500/010/3	C Flange (5)	2500/3	C Flange, drain plug, shaft seal, bolts and washers
2500/080	Drain plug, drive end		
2500/100	Grease nipple, drive end (2)		
2500/280	Shaft seal, drive end (1)		
2500/010/4	C-DIN Flange (5)	2500/4	C-DIN Flange, drain plug, shaft seal, bolts and washers
2500/080	Drain plug, drive end		
2500/100	Grease nipple, drive end (2)		
2500/280	Shaft seal, drive end (1)		
2700/010	Endshield, non-drive end	2700	Endshield, drain plug, shaft seal, bolts and washers
2700/080	Drain plug, non-drive end		
2700/100	Grease nipple, non-drive end (2)		
2700/280	Shaft seal, non-drive end (1)		
2700/470	Wave washer for axial displacement		
5000/010	Cooling Fan	5000	Fan (3)
6000/010	Fan cover (4)	6000	Fan cover, bolts
		6050	Fan cover, drip cover and bolts
6000/100	Drip cover	6100	Drip cover, bolts
6500/010	Terminal box	6500	Terminal box complete with lid, gaskets (for lid and terminal box), plugs (for mains and accessories), earthing terminal, bolts and washers
6500/050	Terminal box gasket		
6500/060	Terminal box lid		
6500/100	Terminal box lid gasket		
6501/010	Terminal box plug for main leads		
6502/010	Terminal box plug for accessory leads		
6590/010	Terminal box earthing terminal		
6531/010	Accessory connector	6531	Accessory connector, mounting rail, bolts and washers
6541/010	Accessory connector	6541	Accessory connector, mounting rail, bolts and washers
6600/010	Accessory terminal box	6600	Accessory terminal box, complete with lid, gasket, plugs, earthing terminal, bolts and washers
6600/060	Accessory terminal box lid		
6600/100	Accessory terminal box lid gasket		
6600/110	Accessory terminal box earthing terminal		
6610/010	Space heater accessory terminal box	6610	Space heater accessory terminal box, complete with lid, gasket, plugs, earthing terminal, bolts and washers
6610/060	Space heater accessory terminal box lid		
6610/100	Space heater accessory terminal box lid gasket		
6610/110	Space heater accessory terminal box earthing terminal		
6800/010	Terminal block	6800	Terminal block, bolts and washers
8500	Main nameplate	8500	Main nameplate

Notes:

- (1) The shaft sealing may vary with product line. As a spare part, the shaft sealing in the 63-112 range will be supplied as an integral part of the endshield kit. If fitted with labyrinth seal, taconite or W3 Seal®, these are available from 90 frame upwards.
- (2) When fitted with grease nipple, the endshield spare part kit will also have grease relief, internal bearing cap and labyrinth seal (taconite or W3 Seal®).
- (3) When non-plastic fan is fitted, the spare part kit is also supplied with key and circlip for fan assembly onto the shaft.
- (4) The fan cover material may vary with product line. Considering general purpose, it is fabricated steel in the 63-112 frame range.
- (5) C flange dimensions according to standards NEMA MG1 Part 4 or DIN.

**Spare Parts Available 132-200**

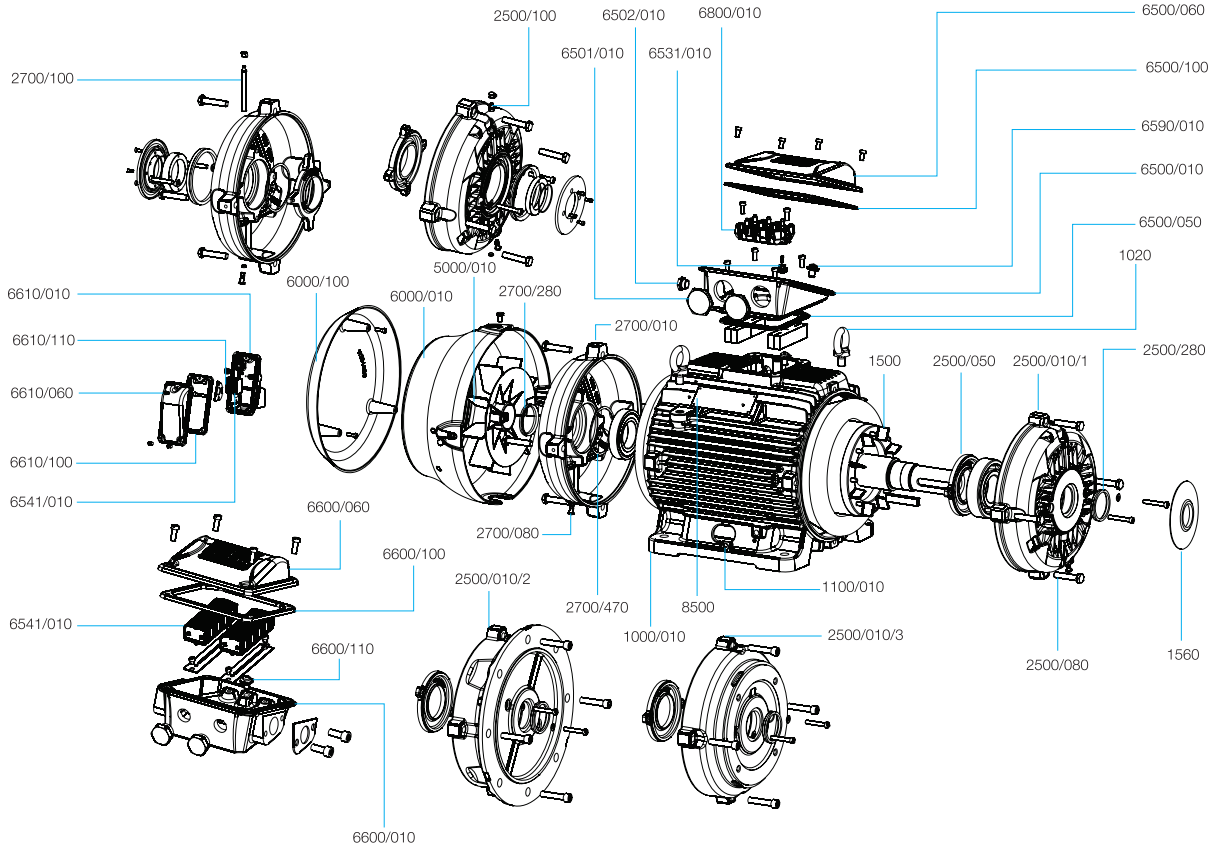

Motor component		Spare part	
Item	Description	Item	Composition
1000/010	Frame with wound stator	1000	Frame with wound stator
1020	Lifting eyebolt	1020	Lifting eyebolt
1100/010	Earthing terminal	1100	Earthing terminal
1500	Rotor, complete with shaft and key	1500	Rotor, complete with shaft and key
1560	Slinger	1560	Slinger (recommended for vertical shaft up applications, non-flange mounted)
2500/010/1	Endshield, drive end	2500/1	Endshield, bearing cap, drain plug, shaft seal, bolts and washers
2500/050	Bearing cap, internal, drive end		
2500/080	Drain plug, drive end		
2500/280	Shaft seal, drive end (1)		
2500/100	Grease nipple, drive end (2)		
2500/010/2	FF Flange	2500/2	FF Flange, drain plug, shaft seal, bolts and washers
2500/080	Drain plug, drive end		
2500/100	Grease nipple, drive end (2)		
2500/280	Shaft seal, drive end (1)		
2500/010/3	C Flange (7)	2500/3	C Flange, drain plug, shaft seal, bolts and washers
2500/080	Drain plug, drive end		
2500/280	Shaft seal, drive end (1)		
2500/100	Grease nipple, drive end (2)		
2700/010	Endshield, non-drive end	2700	Endshield, drain plug, shaft seal, bolts and washers
2700/080	Drain plug, non-drive end		
2700/100	Grease nipple (with extensor pipe), non-drive end (4)		
2700/280	Shaft seal, non-drive end (1)		
2700/470	Wave washer for axial displacement (3)		
5000/010	Fan	5000	Fan (5)
6000/010	Fan cover (6)	6000	Fan cover, bolts
		6050	Fan cover, drip cover and bolts
6000/100	Drip cover	6100	Drip cover and bolts
6500/010	Terminal box	6500	Terminal box, complete with lid, gaskets (for lid and terminal box), plugs (for mains and accessories), earthing terminal, bolts and washers
6500/050	Terminal box gasket		
6500/060	Terminal box lid		
6500/100	Terminal box lid gasket		
6501/010	Terminal box plug for main leads		
6502/010	Terminal box plug for accessory leads		
6590/010	Terminal box earthing terminal		
6531/010	Accessory connector	6531	Accessory connector, mounting rail, bolts and washers
6541/010	Accessory connector	6541	Accessory connector, mounting rail, bolts and washers
6600/010	Accessory terminal box	6600	Accessory terminal box, complete with lid, gasket, plugs, earthing terminal, bolts and washers
6600/060	Accessory terminal box lid		
6600/100	Accessory terminal box lid gasket		
6600/110	Accessory terminal box earthing terminal		
6610/010	Space heater accessory terminal box	6610	Space heater accessory terminal box, complete with lid, gasket, plugs, earthing terminal, bolts and washers
6610/060	Space heater accessory terminal box lid		
6610/100	Space heater accessory terminal box lid gasket		
6610/110	Space heater accessory terminal box earthing terminal		
6800/010	Terminal block	6800	Terminal block, bolts and washers
8500	Main nameplate	8500	Main nameplate

Notes:

- (1) The shaft seal may vary with product line. As a spare part, the shaft seal in the 132-200 range will be supplied as an integral part of the endshield kit. If fitted with labyrinth seal (taconite or W3 Seal) internal bearing cap is mandatory from frame 160.
- (2) When fitted with grease nipple, the endshield spare part kit will also have grease relief.
- (3) Valid when ball bearing is fitted in drive end. When the drive end is fitted with roller bearings, the wave washer is not supplied (non-drive end bearing locked with internal bearing cap).
- (4) When fitted with grease nipple in the non-drive end, the endshield spare part kit will also have grease relief and internal bearing cap.
- (5) When non-plastic fan is fitted, the spare part kit is also supplied with key and circlip for fan assembly onto the shaft.
- (6) The fan cover material may vary with product line. Considering general purpose, it is cast iron in the 160-200 range and fabricated steel in 132 frame.
- (7) C flange dimensions according to NEMA MG1 Part 4 standard (frames 132-200) or DIN standard (frame 132)..

**Spare Parts Available 225 - 355**

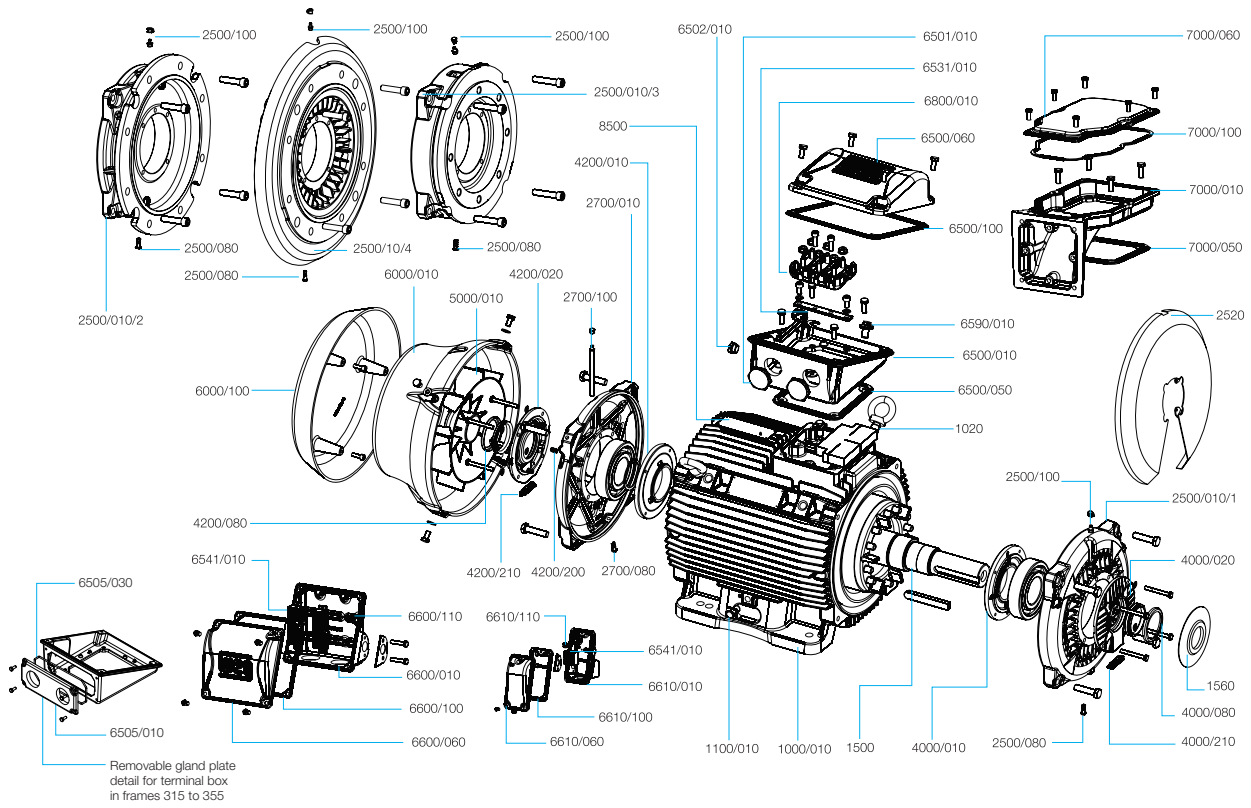

Motor component		Spare part	
Item	Description	Item	Composition
1000/010	Frame with wound stator	1000	Frame with wound stator
1020	Lifting eyebolt	1020	Lifting eyebolt
1100/010	Earthing terminal	1100	Earthing terminal
1500	Rotor, complete with shaft and key	1500	Rotor, complete with shaft and key
1560	Slinger	1560	Slinger
2500/010/1	Endshield, drive end	2500/1	Endshield, grease nipple, drain plug, bolts and washers
2500/080	Drain plug, drive end		
2500/100	Grease nipple, drive end		
2500/010/2	FF Flange	2500/2	FF Flange, grease nipple, drain plug, bolts and washers
2500/080	Drain plug, drive end		
2500/100	Grease nipple, drive end		
2500/0010/3	C Flange (5)	2500/3	C Flange, grease nipple, drain plug, bolts and washers
2500/080	Drain plug, drive end		
2500/100	Grease nipple, drive end		
2500/010/4	FF Flange with air deflector	2500/4	FF Flange with air deflector, grease nipple, drain plug, bolts and washers
2500/080	Drain plug, drive end		
2500/100	Grease nipple, drive end		
2520	Air Deflector	2520	Air Deflector
2700/010	Endshield, non-drive end	2700	Endshield, grease nipple with extensor pipe, drain plug, bolts and washers
2700/080	Drain plug, non-drive end		
2700/100	Grease nipple (with extensor pipe), non-drive end		
4000/010	Bearing cap, internal, drive end	4000	Bearing cap (external and internal), shaft seal, grease relief, bolts and washers
4000/020	Bearing cap, external, drive end		
4000/080	Shaft seal, drive end (1)		
4000/210	Grease relief	4200	Bearing cap (external and internal), shaft seal, grease relief with extensor pipe, pre-load springs, bolts and washers
4200/010	Bearing cap, internal, non-drive end		
4200/020	Bearing cap, external, non-drive end		
4200/080	Shaft seal, non-drive end (1)		
4200/200	Pre-load springs for axial displacement (2)		
4200/210	Grease relief		
5000/010	Fan	5000	Fan (3)
6000/010	Fan cover, cast iron	6000	Fan cover
		6050	Fan cover and canopy
6000/100	Canopy	6100	Canopy
6500/010	Terminal box	6500	Terminal box, complete with lid, gaskets (for lid and terminal box), plugs (for mains and accessories), earthing terminal, bolts and washers
6500/050	Terminal box gasket		
6500/060	Terminal box lid		
6500/100	Terminal box lid gasket		
6501/010	Terminal box plug for main leads		
6502/010	Terminal box plug for accessory leads		
6505/010	Terminal box removable cable gland		
6505/030	Lid gasket of the terminal box removable cable gland		
6531/010	Accessory connector		
6541/010	Accessory connector	6541	Accessory connector, mounting rail, bolts and washers
6590/010	Terminal box earthing terminal	6800	Terminal block, mounting rail, bolts and washers
6800/010	Terminal block		
6600/010	Accessory terminal box		
6600/060	Accessory terminal box lid	6600	Accessory terminal box, complete with lid, gasket, plugs, earthing terminal, bolts and washers
6600/100	Accessory terminal box lid gasket		
6600/110	Accessory terminal box earthing terminal		
6610/010	Space heater accessory terminal box	6610	Space heater accessory terminal box, complete with lid, gasket, plugs, earthing terminal, bolts and washers
6610/060	Space heater accessory terminal box lid		
6610/100	Space heater accessory terminal box lid gasket		
6610/110	Space heater accessory terminal box earthing terminal		
7000/010	Terminal box adaptor base	7000	Terminal box adaptor for side mounted position, complete with lid, gaskets, bolts and washers
7000/050	Terminal box adaptor base gasket		
7000/060	Terminal box adaptor lid		
7000/100	Terminal box adaptor lid gasket		
8500	Main nameplate (4)	8500	Main nameplate

Notes:

- (1) The shaft sealing may vary with product line. As a spare part, the shaft sealing in the 225-355 range will be supplied as an integral part of the bearing cap kit.
- (2) Valid when ball bearing is fitted in drive end. When the drive end is fitted with roller bearings, pre-load springs are not supplied (non-drive end bearing locked).
- (3) When non-plastic fan is fitted, the spare part kit is also supplied with key and circlip for fan assembly onto the shaft.
- (4) Main nameplate position will vary with terminal box configuration (top and side mounting)
- (5) C flange dimensions according to NEMA MG1 Part 4 standard.

# WEG Worldwide Operations

## ARGENTINA

San Francisco - Cordoba  
Phone: +54 3564 421484  
[info-ar@weg.net](mailto:info-ar@weg.net)

Cordoba - Cordoba  
Phone: +54 351 4641366  
[weg-morbe@weg.com.ar](mailto:weg-morbe@weg.com.ar)

Buenos Aires  
Phone: +54 11 42998000  
[ventas@pulverlux.com.ar](mailto:ventas@pulverlux.com.ar)

## AUSTRALIA

Scoresby - Victoria  
Phone: +61 3 97654600  
[info-au@weg.net](mailto:info-au@weg.net)

## AUSTRIA

Markt Piesting - Wiener  
Neustadt-Land  
Phone: +43 2633 4040  
[watt@wattdrive.com](mailto:watt@wattdrive.com)

## BELGIUM

Nivelles - Belgium  
Phone: +32 67 888420  
[info-be@weg.net](mailto:info-be@weg.net)

## BRAZIL

Jaraguá do Sul - Santa Catarina  
Phone: +55 47 32764000  
[info-br@weg.net](mailto:info-br@weg.net)

## CHILE

La Reina - Santiago  
Phone: +56 2 27848900  
[info-cl@weg.net](mailto:info-cl@weg.net)

## CHINA

Nantong - Jiangsu  
Phone: +86 513 85989333  
[info-cn@weg.net](mailto:info-cn@weg.net)

Changzhou - Jiangsu  
Phone: +86 519 88067692  
[info-cn@weg.net](mailto:info-cn@weg.net)

## COLOMBIA

San Cayetano - Bogota  
Phone: +57 1 4160166  
[info-co@weg.net](mailto:info-co@weg.net)

## ECUADOR

El Batán - Quito  
Phone: +593 2 5144339  
[ceccato@weg.net](mailto:ceccato@weg.net)

## FRANCE

Saint-Quentin-Fallavier - Isère  
Phone: +33 4 74991135  
[info-fr@weg.net](mailto:info-fr@weg.net)

## GERMANY

Türnich - Kerpen  
Phone: +49 2237 92910  
[info-de@weg.net](mailto:info-de@weg.net)

Balingen - Baden-Württemberg  
Phone: +49 7433 90410  
[info@weg-antriebe.de](mailto:info@weg-antriebe.de)

Homburg (Efze) - Hesse  
Phone: +49 5681 99520  
[info@akh-antriebstechnik.de](mailto:info@akh-antriebstechnik.de)

## GHANA

Accra  
Phone: +233 30 2766490  
[info@zestghana.com.gh](mailto:info@zestghana.com.gh)

## INDIA

Bangalore - Karnataka  
Phone: +91 80 41282007  
[info-in@weg.net](mailto:info-in@weg.net)

Hosur - Tamil Nadu  
Phone: +91 4344 301577  
[info-in@weg.net](mailto:info-in@weg.net)

## ITALY

Cinisello Balsamo - Milano  
Phone: +39 2 61293535  
[info-it@weg.net](mailto:info-it@weg.net)

## JAPAN

Yokohama - Kanagawa  
Phone: +81 45 5503030  
[info-jp@weg.net](mailto:info-jp@weg.net)

## MALAYSIA

Shah Alam - Selangor  
Phone: +60 3 78591626  
[info@wattdrive.com.my](mailto:info@wattdrive.com.my)

## MEXICO

Huehuetoca - Mexico  
Phone: +52 55 53214275  
[info-mx@weg.net](mailto:info-mx@weg.net)

Tizayuca - Hidalgo  
Phone: +52 77 97963790

## NETHERLANDS

Oldenzaal - Overijssel  
Phone: +31 541 571080  
[info-nl@weg.net](mailto:info-nl@weg.net)

## PERU

La Victoria - Lima  
Phone: +51 1 2097600  
[info-pe@weg.net](mailto:info-pe@weg.net)

## PORTUGAL

Maia - Porto  
Phone: +351 22 9477700  
[info-pt@weg.net](mailto:info-pt@weg.net)

## RUSSIA and CIS

Saint Petersburg  
Phone: +7 812 363 2172  
[sales-wes@weg.net](mailto:sales-wes@weg.net)

## SOUTH AFRICA

Johannesburg  
Phone: +27 11 7236000  
[info@zest.co.za](mailto:info@zest.co.za)

## SPAIN

Coslada - Madrid  
Phone: +34 91 6553008  
[wegiberia@wegiberia.es](mailto:wegiberia@wegiberia.es)

## SINGAPORE

Singapore  
Phone: +65 68589081  
[info-sg@weg.net](mailto:info-sg@weg.net)

Singapore  
Phone: +65 68622220  
[watteuro@watteuro.com.sg](mailto:watteuro@watteuro.com.sg)

## SCANDINAVIA

Mölnlycke - Sweden  
Phone: +46 31 888000  
[info-se@weg.net](mailto:info-se@weg.net)

## UK

Redditch - Worcestershire  
Phone: +44 1527 513800  
[info-uk@weg.net](mailto:info-uk@weg.net)

## UNITED ARAB EMIRATES

Jebel Ali - Dubai  
Phone: +971 4 8130800  
[info-ae@weg.net](mailto:info-ae@weg.net)

## USA

Duluth - Georgia  
Phone: +1 678 2492000  
[info-us@weg.net](mailto:info-us@weg.net)

Minneapolis - Minnesota  
Phone: +1 612 3788000

## VENEZUELA

Valencia - Carabobo  
Phone: +58 241 8210582  
[info-ve@weg.net](mailto:info-ve@weg.net)

For those countries where there is not a WEG own operation, find our local distributor at [www.weg.net](http://www.weg.net).



WEG Group - Motors Business Unit  
Jaraguá do Sul - SC - Brazil  
Phone: +55 47 3276 4000  
[motores@weg.net](mailto:motores@weg.net)  
[www.weg.net](http://www.weg.net)

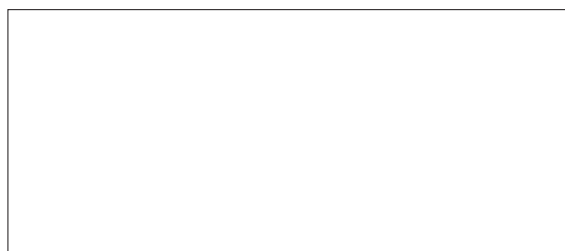

Cod: 50025712 | Rev: 25 | Date (m/y): 10/2016  
The values shown are subject to change without prior notice.