



User manual easyE-i-line

Configurations:

Configurations	SDB (S2-1) Single Actuator Direction Control Basic IO	SDH (S2-1+hall) Single Actuator Direction Control Hall Output	SDP (S2-1+pos.out) Single Actuator Direction Control Position Output	SPP (S2-2) Single Actuator Position Control Position Output	SBS (bus based) Single Actuator BUS Control Status / Control IO	MDO (synchronization) Multiple Actuators Direction Control Override
Configuration letter	A	B	C	D	E	F
Voltage 12/24 VDC	✓	✓	✓	✓	✓	✓
Direction in/out	✓	✓	✓	-	-	✓
5/10 VDC ref. output	-	-	-	✓	-	-
Stop input	-	-	-	-	✓	-
Override input	-	-	-	-	-	✓
Error output	-	-	-	-	✓	-
Analog position input	-	-	-	✓	-	-
Analog position output	-	-	✓	-	-	-
Stop input / Pos. OK output	-	-	-	✓	-	-
Hall Output	-	✓	-	-	-	-

All easyE-i-line actuators come with 8-pin Molex mini fit JR connector unless specified otherwise. The connections for each configuration are shown in the table below.

Configurations	SDB	SDH	SDP	SPP	SBS	MDO
Key letter	A	B	C	D	E	F
Color						
Yellow (2)	RS485 TX +A	RS485 TX +A	RS485 TX +A	RS485 TX +A	RS485 TX +A	RS485 TX +A
Green (1)	RS485 RX -B	RS485 RX -B	RS485 RX -B	RS485 RX -B	RS485 RX -B	RS485 RX -B
Orange (3)	GND Signal	Hall B output	GND Signal	GND Signal	GND Signal	GND Signal
Black (4)	GND Power	GND Power	GND Power	GND Power	GND Power	GND Power
White (7)	Not used	Hall A output	Position output	5-10V reference	Not used	Override
Brown (6)	Dir. IN	Dir. IN	Dir. IN	Pos ok/stop input	Error out	Dir. IN
Blue (5)	Dir. OUT	Dir. OUT	Dir. OUT	Position input	Stop input	Dir. OUT
Red (8)	Power 12/24V	Power 12/24V	Power 12/24V	Power 12/24V	Power 12/24V	Power 12/24V

For all configurations except SDH, Signal GND (pin 3) and Power GND (pin 4) must be connected at the end of the actuator cable, i.e., at the Molex minifit JR connector. This connection is established inside the i-Connect-Box units but can be removed with a jumper. Please refer to installation guide for further details.

The numbers in the (parentheses) refer to the Molex minifit layout.

Bansbach Actuator Studio

Bansbach Actuator Studio (BAS) is the software package, which is used to set parameters and control the actuators during the development and test phase.

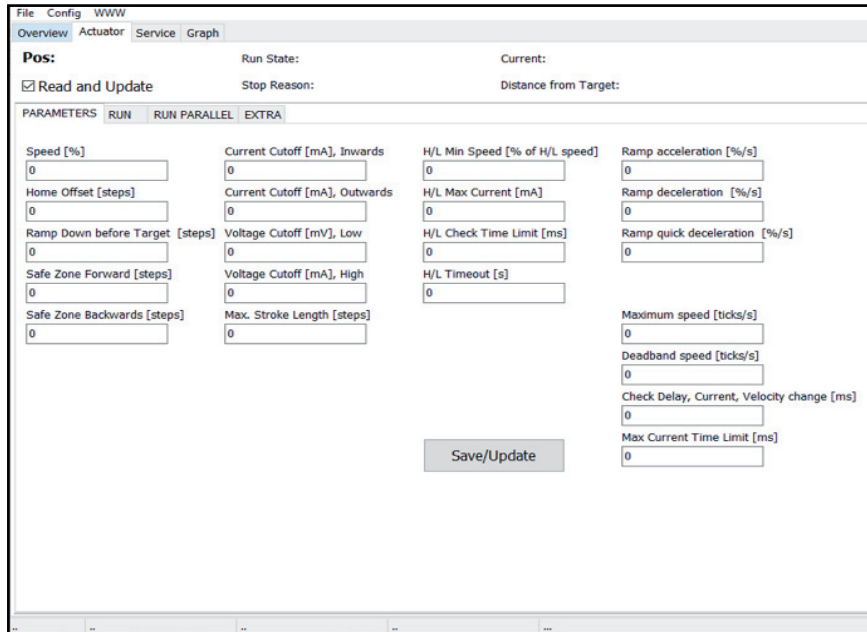

BAS can be downloaded from the Bansbach website: www.bansbach.com/config-tool

To connect the actuator to BAS, we recommend using the Bansbach programming cable:



When BAS is started, it initially shows a window with information about version etc. This window closes automatically after 10 seconds or can be closed manually and then the overview screen appears.

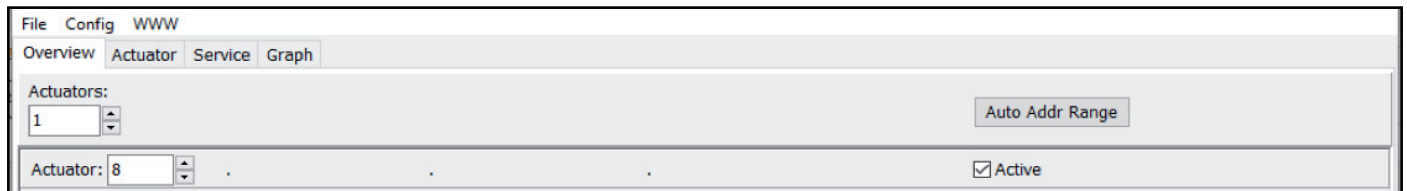

The number of actuators connected can be adjusted and the number of lines shown in the overview window will change accordingly. Only one actuator can be active and operated in BAS at a time; however, it is possible to see all actuators in the overview. If an actuator is recognized the uptime counter will be counting if „Active“ is ticked.

When more actuators are connected, they must have different addresses. All single setup actuators come with default address 8. This can be changed under the „Service/Config“ tab. Enter new address in „Modbus address“ and click „Save/Update“.

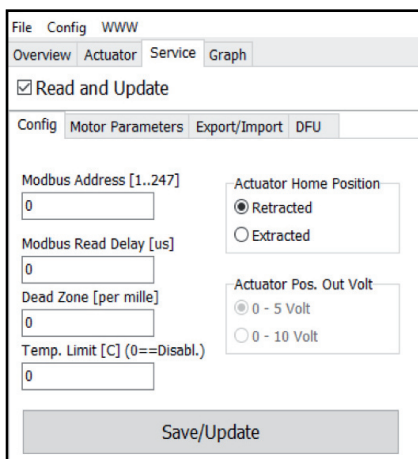

Address range for single actuators is 1 to 199. Multi setup actuators (MDO) are preset to addresses from 200 to 207 with 200 being „Master“ (please refer to MDO section).

Basic operation

Actuators use pulses generated by motor revolutions to control position and to synchronize more actuators running in a multiple actuator setup.

All actuators are configured and initialized from factory, but it may be required to perform additional initialization during installation to ensure proper operation. This is done using the “Home” and “Learn” functions in BAS. Home returns the piston to the fully retracted position and stores this position as “Home” (Position 0). The Learn function runs a full cycle and determines both fully retracted and fully extracted positions of the piston. Please note that these positions may be determined by physical limitations in the mechanical design of the application and not by the end positions of the actuator.

Click the “Run Learn” under the “Service/Config” tab to perform a learn cycle. If required by the application, “Home” position can be changed to fully extracted position and speed during learn can be adjusted. All actuators in a multiactuator setup must be “Homed” individually.

The screenshot shows the BAS software interface with the following elements:

- Menu bar: File, Config, WWW
- Navigation tabs: Overview, Actuator, Service, Graph
- Checkmark: Read and Update
- Sub-tabs: Config, Motor Parameters, Export/Import, DFU
- Input fields: Modbus Address [1..247] (0), Modbus Read Delay [us] (0), Dead Zone [per mille] (0), Temp. Limit [C] (0==Disabl.) (0)
- Radio buttons: Actuator Home Position (Retracted selected), Actuator Pos. Out Volt (0 - 5 Volt selected)
- Buttons: Save/Update, Run Learn, Stop, Partial Reset Actuator
- Learn BASIC section: Learn Home selected, Learn Positions unselected
- Speed [%] dropdown: 5

Please note: Learn will reset settings for „Range Scale“.

Other basic parameters that can be adjusted under the „Actuator/Parameters“ tab.

The screenshot shows a web-based configuration interface for an actuator. At the top, there are menu items: File, Config, WWW. Below that are tabs: Overview, Actuator (selected), Service, Graph. The main area is titled 'Pos:' and contains several status indicators: Run State, Current, Stop Reason, and Distance from Target. A checkbox labeled 'Read and Update' is checked. Below this is a sub-tabbed section for 'PARAMETERS' with options for RUN, RUN PARALLEL, and EXTRA. The parameters are organized into four columns:

Parameter	Value	Parameter	Value	Parameter	Value	Parameter	Value
Speed [%]	0	Current Cutoff [mA], Inwards	0	H/L Min Speed [% of H/L speed]	0	Ramp acceleration [%/s]	0
Home Offset [steps]	0	Current Cutoff [mA], Outwards	0	H/L Max Current [mA]	0	Ramp deceleration [%/s]	0
Ramp Down before Target [steps]	0	Voltage Cutoff [mV], Low	0	H/L Check Time Limit [ms]	0	Ramp quick deceleration [%/s]	0
Safe Zone Forward [steps]	0	Voltage Cutoff [mA], High	0	H/L Timeout [s]	0		
Safe Zone Backwards [steps]	0	Max. Stroke Length [steps]	0			Maximum speed [ticks/s]	0
						Deadband speed [ticks/s]	0
						Check Delay, Current, Velocity change [ms]	0
						Max Current Time Limit [ms]	0

At the bottom center, there is a 'Save/Update' button.

As a part of a learn cycle, „Safe Zone“ values are default set 50 steps (backwards) and full stroke-50 steps (forward). If stroke length is entered manually, it is necessary also to enter safe zone values.

SDB (Single Actuator / Direction Control / Basic IO)

The SDB is the basic version of the easyE-i-line family. It is recognized by the capital letter A in the part number. The SDB version can be used as a “Plug and Play” solution controlled by a simple handset, two dry contacts or by a PLC. The i-Connect-Box / i-Connect-Box DIN can be used as an interface. Please refer to i-Connect-Box documentation for further details.

Block diagram

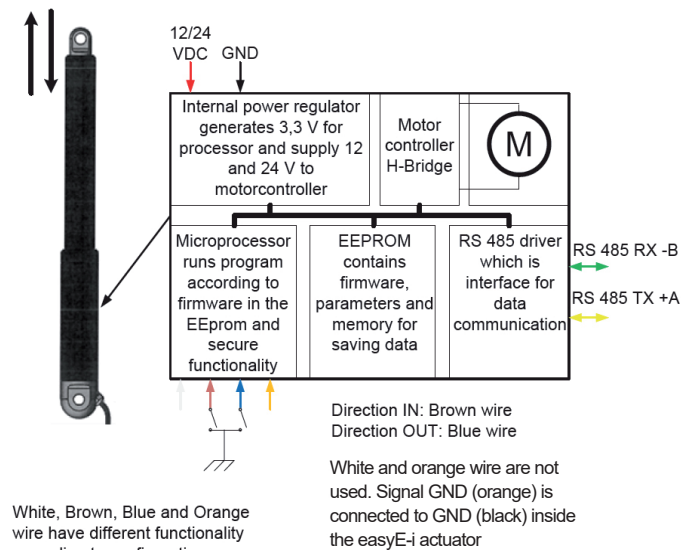

Configurations	SDB
Key letter	A
Color (pin no.)	
Green (1)	RS485 TX -B
Yellow (2)	RS485 RX +A
Orange (3)	GND Signal
Black (4)	GND
Blue (5)	Direction OUT
Brown (6)	Direction IN
White (7)	Not used
Red (8)	Power 12/24V

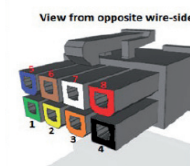

Pin numbers refer to Molex 8-pin connector. Signal GND and Power GND is connected inside.

SDB has inputs for direction (in/out) and feedback. Pin 5 and pin 6 are used for direction commands. They are active low and must be pulled to power GND to activate. If pin 5 and pin 6 are connected to GND simultaneously for more than 10 seconds, Homing/Learning is started. During this the actuator travel at a lower speed and it is important that neither of the brackets can rotate freely. 0-point - (Homing) and maximum stroke length (Learning) are saved during this cycle.

Interconnection/Modbus control

The SDB can also be controlled via Modbus with the same functions as mentioned above. More SDB can be connected to the same bus if they have individual addresses. If controlled with Modbus it is still possible to override with input from handset or contacts. However, the handset or contact-set should be, either common for all or each would need its own.

Application example with actuator connected to PLC with Modbus interface via i-Connect-Box DIN:

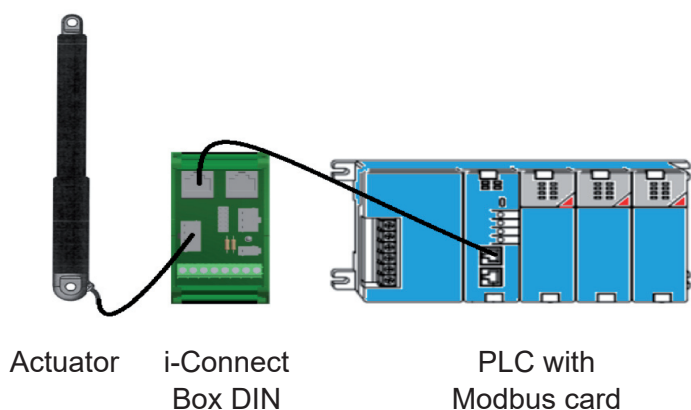

SDH (Single Actuator / Direction Control / Hall output)

The SDH configuration provides the same features as SDB and in addition to this, it has outputs for hall signals. SDH is recognized by the capital letter B in the part number. The SDH version can work as a “Plug and Play” solution controlled by a simple handset with two dry contacts or by a PLC. The i-Connect-Box / i-Connect-Box DIN is used as an interface for these options. Please refer to i-Connect-Box documentation for further details.

Block diagram

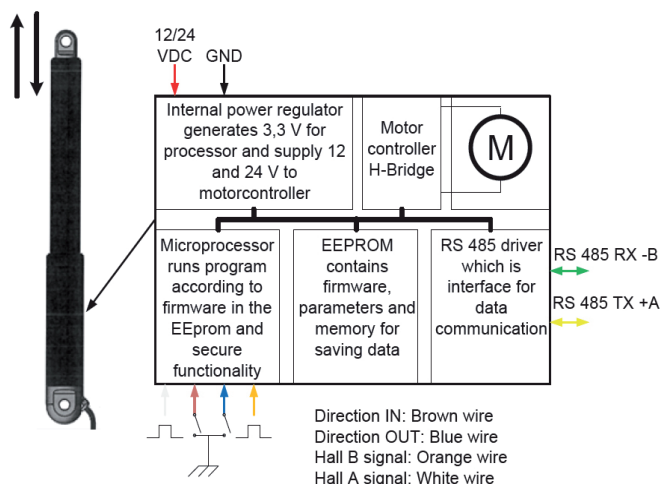

Configurations	SDH
Key letter	B
Color (pin no.)	
Green (1)	RS485 -B
Yellow (2)	RS485 +A
Orange (3)	Hall B Signal
Black (4)	GND
Blue (5)	Direction OUT
Brown (6)	Direction IN
White (7)	Hall A Signal
Red (8)	Power 12/24V

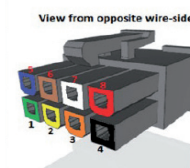

White, Brown, Blue and Orange wire have different functionality according to configuration

See Data sheet for more information

SDH has inputs for direction (in/out) and two channel hall outputs. Pin 5 and pin 6 are active low and must be pulled down to power GND to activate. The hall channels at pin 3 and pin 7 are 3.3 Vpp square wave signal (max 5mA) with a 50% duty cycle and a 90° phase shift. Hall outputs are NPN logic TTL level. If pin 5 and pin 6 are connected to GND simultaneously for more than 10 seconds, Homing/Learning is started. During this the actuator travels at a lower speed and it is important that neither of the brackets can rotate freely. 0-point - (Homing) and maximum stroke length (Learning) are saved during this cycle. Special function for SDH is hall output at pin 3 (hall A) and pin 7 (hall B)

Interconnection/Modbus control

The SDB can also be controlled via Modbus with the same functions as mentioned above. More SDB can be connected to the same bus if they have individual addresses. If controlled with Modbus it is still possible to override with input from handset or contacts. However, the handset or contact-set should be, either common for all or each would need its own.

Application example with actuator connected to PLC with Modbus interface via i-Connect-Box DIN:

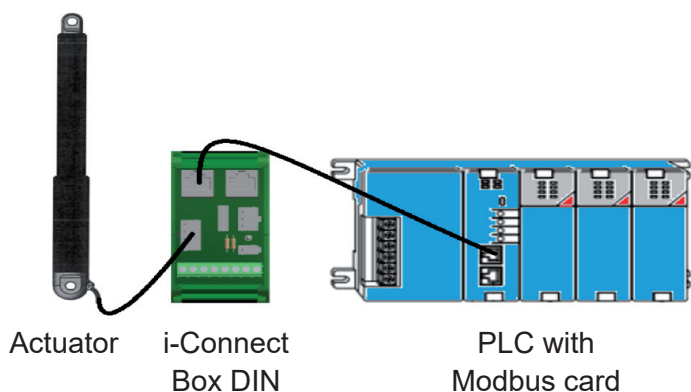

SDP (Single Actuator / Direction Control / Position output)

The SDP configuration provides the same features as SDB and in addition to this, it has an analogue position output. SDP is recognized by the capital letter C in the part number. The SDP version can work as a “Plug and Play” solution controlled by a simple handset with two dry contacts or by a PLC.

The i-Connect-Box / i-Connect-Box DIN can be used as an interface.

Please refer to conXion Box/Box+/DIN documentation for further details.

Block diagram

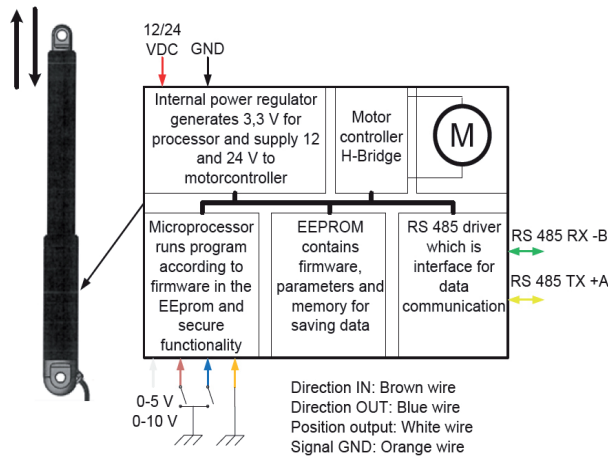

White, Brown, Blue and Orange wire have different functionality according to configuration

See Data sheet for more information

Configurations	SDP
Key letter	C
Color (pin no.)	
Green (1)	RS485 -B
Yellow (2)	RS485 +A
Orange (3)	GND Signal
Black (4)	GND
Blue (5)	Direction OUT
Brown (6)	Direction IN
White (7)	Pos. voltage OUT
Red (8)	Power 12/24V

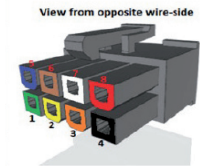

Numbers refer to pin layout of the 8-pin Molex plug.

SDP has inputs for direction (in/out), and analog feedback output for position. The inputs for direction at pin 5 and pin 6 are active low and must be pulled to power GND to activate. Pin 7 is an analog output that relate to the actual position of the piston. The output has two ranges, which can be selected in BAS: 0-5 VDC and 0-10 VDC for 24 VDC, but only 0-5 V range for 12 VDC. Power GND and Signal GND must be connected at the PLC or at the end of the cable. If pin 5 and pin 6 are connected to GND simultaneously for more than 10 seconds, Homing/Learning is started. During this the actuator travel at a lower speed and it is important that neither of the brackets can rotate freely. 0-point - (Homing) and maximum stroke length (Learning) are saved during this cycle.

Interconnection/Modbus control

The SDP configuration can also be controlled by Modbus but with the same limitations as already mentioned. You can add numerous SDP to your application if each is provided with an individual address. If controlled with Modbus it is still possible to override with analog input from handset or contacts. However, the handset or contact-set should be, either common for all or each would need its own.

Application example with actuator connected to PLC with Modbus interface via i-Connect-Box DIN:

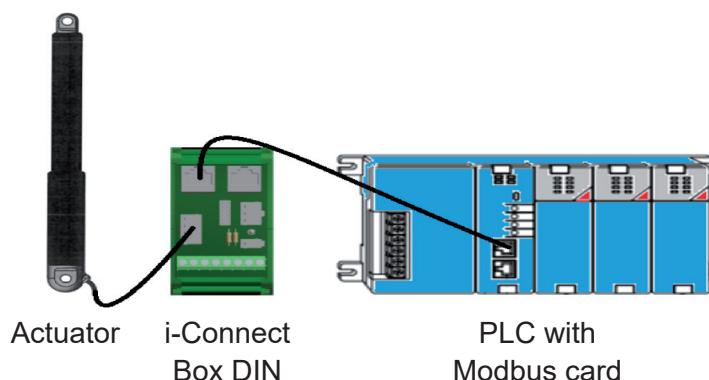

SPP (Single Actuator / Position Control / Position output)

The SPP configuration has the same features as SDB and in addition to this it has an analog position input and a position OK output. It is recognized by the capital letter D in the part number. With SPP the position of the actuator can be controlled by an analogue voltage, i.e. for example 5 VDC will move the piston to 50% stroke if 10 VDC input range is used.

The i-Connect Box / i-Connect-Box DIN is used as an interface for these options, but it is free for using other options. Please refer to i-Connect-Box / i-Connect-Box DIN documentation for further details.

Modbus control is not recommended with the SPP configuration as the analogue input always has higher priority than Modbus commands.

Block diagram

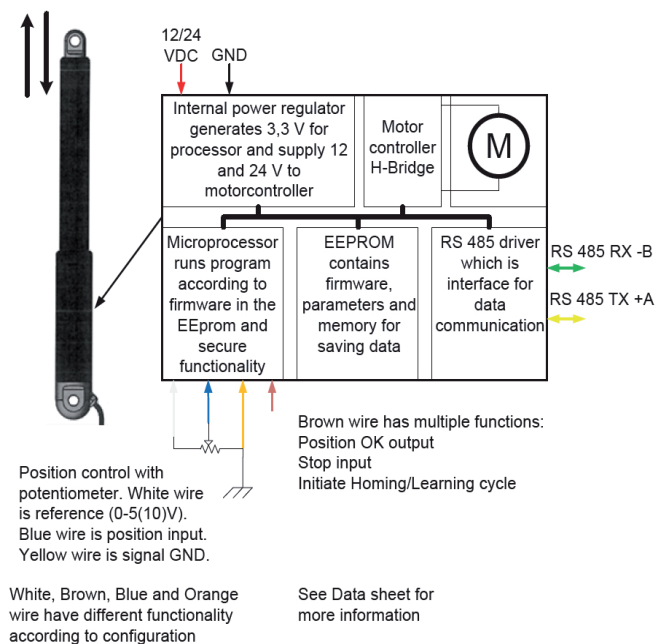

Configurations	SPP
Key letter	D
Color (pin no.)	
Green (1)	RS485 -B
Yellow (2)	RS485 +A
Orange (3)	GND Signal
Black (4)	GND
Blue (5)	Pos. IN
Brown (6)	Pos. OK OUT / stop IN
White (7)	5-10 VDC
Red (8)	Power 12/24V

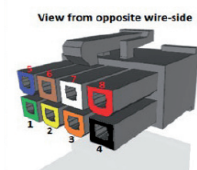

The SPP has an analog input for positioning at pin 5 and a reference output at pin 7. Reference voltage is selectable via BAS, i.e., 5 or 10 VDC (5 VDC only for 12 VDC actuators). Pin 6 has combined purpose for "Position OK", "STOP", and "Home/Learn". Under normal conditions pin 6 is "high" (3.3 VDC/max 5mA) when the actuator is moving. When target position is reached it signals "Position OK" by switching to 0 V (low) and actuator stops. In addition to this, pin 6 can also be used as input by pulling it down to GND. This will stop the actuator. If pin 6 is connected to pin 5 during power up the Homing/Learning cycle is activated.

SBS (Single Actuator / Bus Control / Status Control IO)

The SBS configuration is designed for Modbus communication and control only. It has, however, one digital stop input and one digital error output. SBS is recognized by the capital letter E in the part number.

Block diagram

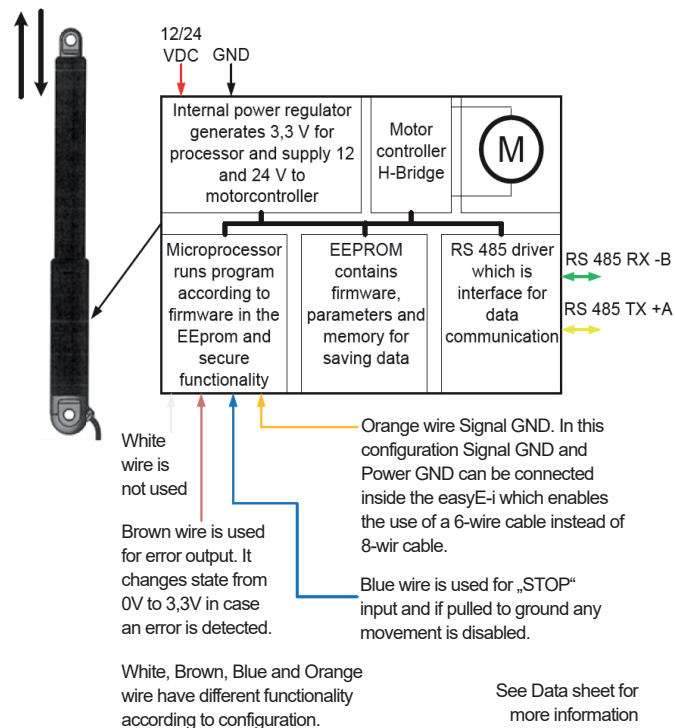

Configurations	SBS
Key letter	E
Color (pin no.)	
Green (1)	RS485 -B
Yellow (2)	RS485 +A
Orange (3)	GND Signal
Black (4)	GND
Blue (5)	Stop IN
Brown (6)	Error OUT
White (7)	Not used
Red (8)	Power 12/24V

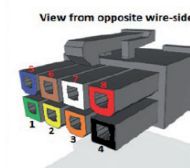

Pin 5 (active low) is a digital stop input, which disables the motor drivers completely. Pin 6 (active high) is a fault output. Any fault detected is indicated by a change from 0 VDC to 3.3 VDC at this pin. Pin 3 is a signal GND connection. The i-Connect-Box / i-Connect-Box DIN can be used as interface. Please refer to i-Connect-Box / i-Connect-Box DIN documentation for further details.

Interconnection/Modbus control

The interconnection of SBS is illustrated below. Up to 10 easyE-i actuators can be connected in the same setup without additional hardware. More than 10 units require a Modbus hub or similar.

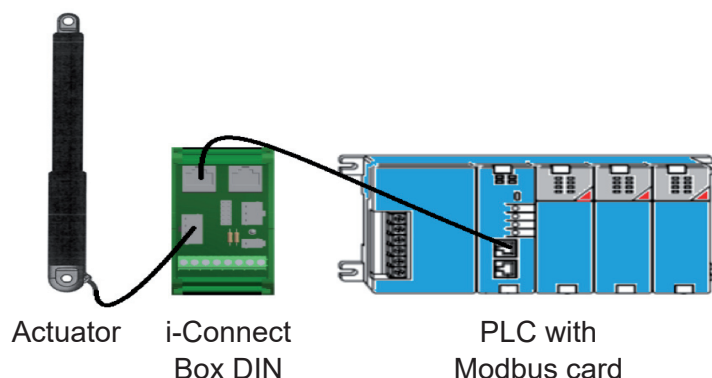

MDO (Multiple Actuator / Direction Control / Override)

The MDO is designed to work in a multi-actuator setup. It allows up to eight actuators to run synchronized sharing a common load based on the master/slave principle. MDO is recognized by the capital letter F in the part number. The i-Connect-Box / i-Connect-Box DIN can be used to cascade the actuators to simplify wiring etc. Please refer to i-Connect-Box / i-Connect-Box DIN documentation for further details.

It is not possible to control an MDO setup via Modbus as this bus is used for synchronization purposes.

Block diagram

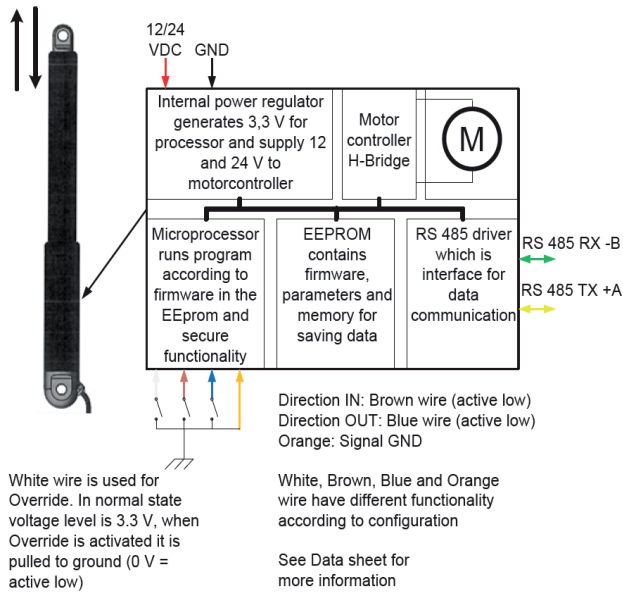

Configurations	MDO
Key letter	F
Color (pin no.)	
Green (1)	RS485 -B
Yellow (2)	RS485 +A
Orange (3)	GND Signal
Black (4)	GND
Blue (5)	Direction OUT
Brown (6)	Direction IN
White (7)	Override
Red (8)	Power 12/24V

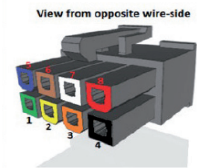

All actuators in an MDO setup must have different addresses with the master being number 200 and slaves counting from 201 to 207. All other parameters must be identical. This is configured from factory but can be changed via BAS. Please refer to Basic Operation section to perform Homing of the actuators and please note that all actuators in an MDO setup must be Homed individually. Pin 5 and pin 6 of the master are used to control the actuators out and in respectively. Both pins are active low, i.e. they need to be pulled down to GND to activate. Pin 7 is an override input (active low), which enables individual travel (adjustment) of one actuator in the setup. After activating pin 7, pin 5 and pin 6 on the specific actuator can be used to move the piston.

Interconnection

The figure below shows an MDO setup with i-Connect-Box DIN units connected to a PLC using the Direction Out and Direction In pins on the master actuator.

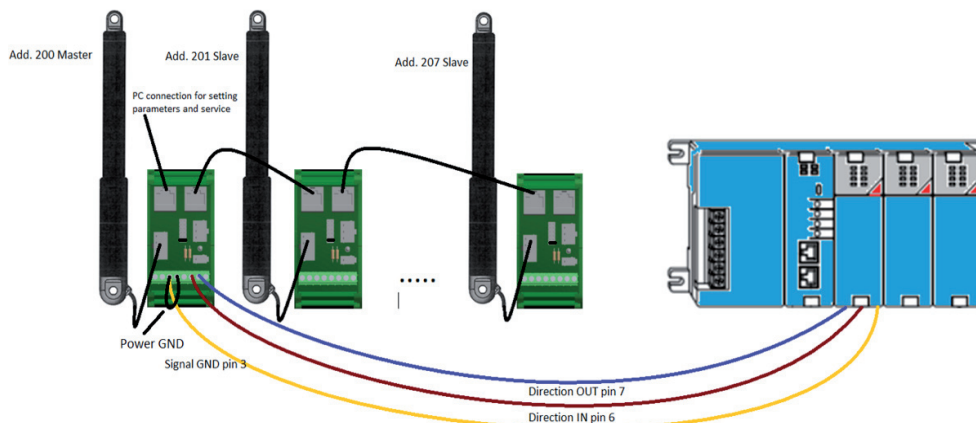

Products and accessories - incl. Part No.



i-Connect Box
EEL-I-CONNECT

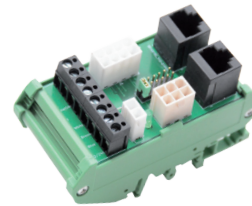

i-Connect Box DIN
EEL-I-CONNECT-DIN



Handset
EEL-HS3-A-MOL-A



Power supply 24VDC/2A (EU/UK/US/AU)
EEL-I-PW-24V-2A



Programming cable (USB-RS485)
EEL-I-PROGUSB

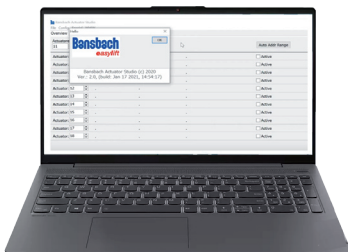

Bansbach software BAS
Bansbach Actuator Studio



Cable
EEL-I-RJ45-0.25 / -1.0 / -5.0 / -10 / -20 (length)

Recommendations and warnings

- Wrong polarity of power supply can damage the actuator
- Be sure to use a power supply, which can provide at least 150% of nominal power of each actuator.

Subject to technical changes and printing mistakes.

Bansbach easylift GmbH

Barbarossastraße 8
D-73547 Lorch

Tel. +49 (0) 7172/9107-0
Fax +49 (0) 7172/9107-44

info@bansbach.de
www.bansbach.de

Bansbach
easylift

02/2022